

Measuring and Understanding Sound

WITHIN GENERATOR APPLICATIONS

INTRODUCTION

When selecting a generator, there are many factors to consider so as not to negatively impact the existing environment. Today, noise is considered a pollutant and a negative health factor. This paper discusses the basics of sound, how it is measured, and defines enclosure sound levels. Those responsible for generator design and installation have to consider the local environmental impact noise will have on populated areas, and their considerations will have to consider noise regulations set by Occupational Safety and Health Administration (OSHA) and state and municipal noise ordinances.

Across North America, local, state or federal zoning ordinances limit the noise that can be measured at lot lines. Within working environments, OSHA states workers cannot be subjected to more than 80 dBA for more than a set period. This paper discusses the basics of sound, its definitions, what the human ear hears, sound measurement and solutions for reducing noise transmitted to the environment.

BASICS OF SOUND

SOUND PRESSURE VERSUS SOUND POWER

There are two common measures to quantify the level of sound: sound pressure and sound power. Both are often presented as levels using decibel (dB) units; however, there is a significant difference between sound pressure and sound power. Sound pressure is measured with a microphone. The measured sound pressure level from a generator set will depend heavily on the distance between the microphone and the source and the surrounding environment. In a free-field environment, basically no reflecting surfaces near the

generator, the sound pressure level will reduce 6 dB for every doubling of distance. Sound power is a calculated measure. Specifically, it is not measured directly but calculated from sound pressure measurements. While sound pressure levels are heavily dependent on the distance between the microphone and the generator, the calculated sound power is constant as it factors the measured distance into the calculation.

Since sound pressure is dependent on the measurement distance, one must ensure that the distance from the generator set is considered when comparing levels between various products and reviewing noise ordinances.

BASICS OF SOUND

DB SCALE

The dB scale was developed to define the effect of sound on the human ear. It is logarithmic, as the scale of sound the ear first detects 0 dB(A) to a level that is intolerable 120 dB(A), is approximately 10 million to one. A base 10 logarithmic scale as depicted in *Figure 1* covers the range of human hearing from 0 dB (barely audible) to 140 dB (painful on the ear).

DIFFERENCE BETWEEN DB(A) AND DBB

Loudness is the human ear's impression of the strength of a sound.

The human ear is more sensitive to sound in the 1 to 4 kHz frequency range than to sound at very low or very high frequencies. To compensate for human hearing, sound meters are normally fitted with filters that adapt the measured sound response to the human sense of sound.

Figure 1

| Outdoor Sounds | dB(A) | Indoor sounds |
|---------------------------|-------|-----------------------------|
| | 140 | Threshold of pain |
| Gunshot | 135 | |
| | 130 | |
| Jackhammer | 125 | |
| Thunder | 120 | Rock Band |
| | 115 | |
| Chain Saw | 110 | |
| Car Horn | 105 | |
| Snowmobile | 100 | Hair Dryer |
| Gas Lawn Mower | 95 | Garbage Disposal |
| | 90 | Factory Noise |
| Street Traffic | 85 | Vacuum Cleaner |
| Busy Urban Area | 80 | Dog Barking |
| | 75 | Normal Speech |
| Commercial Area | 70 | Business Office |
| | 65 | Dishwasher |
| | 60 | Average Home |
| Quiet Urban Daytime | 55 | Theater |
| | 50 | Living Room |
| Quiet Urban Nighttime | 45 | Library |
| Raindrops | 40 | Quiet Conversation |
| Quiet Suburban, Nighttime | 35 | Bedroom |
| | 30 | Soft Whisper |
| Quiet Rural Nighttime | 25 | Recording Studio |
| Rustling Leaves | 20 | |
| | 15 | |
| | 10 | |
| | 5 | |
| | 0 | Threshold of hearing |

The A scale and B scale were developed for different levels of sound. The most commonly used scale is the A scale with units of dB(A). When measuring generator sound on the human ear, the A scale is used.

See *Figure 2* with AB scales, note the A scale.

FREQUENCY OF SOUND OCTAVE BANDS

Octave Bands offer a filtering method of splitting the audible spectrum into smaller segments called octaves, allowing you to identify different noise levels across individual frequencies.

Octave Band measurements are used when the frequency composition of a sound field is needed to be determined. Octave analysis is often used in noise control, hearing protection and sometimes in environmental noise issues.

Common octave frequency bands are: 63 Hz, 125 Hz, 250 Hz, 500 Hz, 1 kHz, 2 kHz, 4 kHz and 8 kHz. Their composition is made up of the Lower Band Limit, Centre Frequency and Upper Band Limit. *Figure 3*.

Figure 2

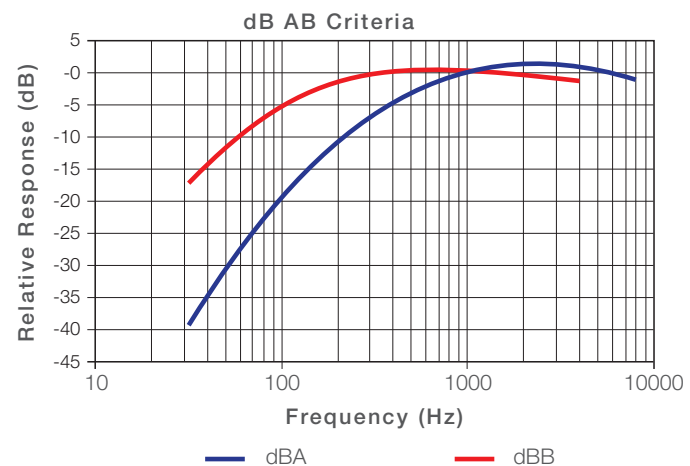

IMPORTANCE OF SOUND FOR POWER GENERATION

WHY MEASURE SOUND

Regulatory bodies such as OSHA mandate no more than 80 dB(A) to the ear for more than 8 hours in a day. Local ordinances also set noise limits within populated areas.

Generator systems are supplied in an open configuration for inside installations and in weather-protective enclosures for outside installations. In noise-regulated areas, fully sound attenuated enclosure will keep sound emissions within given limits.

Kohler measures the sound emitted by all its generator systems, whether open or fully sound attenuated, to ensure the generator selected is within site location noise emissions.

HOW SOUND IS MEASURED

Sound measurements, to international standards, are taken for all three generator configurations:

- Weather-protective enclosure
- Level “1 to 2” sound enclosures
- Open generator set

Sound measurements can be affected by surrounding structures, humidity, topography, etc. For consistency, measurements are taken in an open area to set industry standards. *Figure 4.*

Figure 3: Sound Pressure Levels dB(A) – Enclosure Level-1 Sound

| Measurement Clock Position | Octave Band Frequency (Hz) | | | | | | | | Overall Level |
|----------------------------|----------------------------|------|------|------|------|------|------|------|---------------|
| | 63 | 125 | 250 | 500 | 1000 | 2000 | 4000 | 8000 | |
| 3:00 | 67.8 | 75.4 | 76.3 | 77.6 | 76.0 | 76.1 | 68.5 | 62.7 | 83.6 |
| 1:30 | 68.1 | 78.5 | 86.4 | 90.9 | 85.7 | 82.6 | 81.9 | 72.7 | 93.9 |
| Noon | 67.8 | 81.6 | 87.8 | 90.8 | 89.3 | 83.2 | 78.6 | 72.0 | 95.3 |
| 10:30 | 66.0 | 74.8 | 84.6 | 87.7 | 82.2 | 78.7 | 78.8 | 70.6 | 90.9 |
| 9:00 | 60.6 | 70.7 | 74.2 | 76.2 | 69.9 | 67.0 | 61.6 | 60.8 | 79.9 |
| 7:30 | 61.5 | 74.0 | 77.2 | 78.8 | 77.0 | 77.9 | 69.9 | 60.3 | 84.4 |
| 6:00 | 64.7 | 71.7 | 72.8 | 69.2 | 67.7 | 65.2 | 57.0 | 46.3 | 77.4 |
| 4:30 | 63.8 | 74.7 | 75.9 | 76.3 | 76.1 | 75.0 | 69.1 | 63.9 | 82.9 |
| 8-pos. log avg. | 65.8 | 76.5 | 82.7 | 86.1 | 82.8 | 78.8 | 76.2 | 68.2 | 90.0 |

Per *Figure 4* Measurements are taken in an open area with eight microphones set in clock positions indicated above. The chart depicts sound measurements with the 100% generator loaded.

MEASURING SOUND OF ENCLOSED SET

Fully enclosed generator sets, whether in a weather protective canopy or fully sound attenuated enclosure, are tested unloaded and loaded up to 100% of rated load. The measurements will include all sound sources including the exhaust. Sound readings, with an approved decibel meter set to the “A” weighted scale, are taken at eight equidistant measurement locations 7 meters (23 feet) from the profile. The microphones are set at 1 meter high as detailed in *Figure 4.*

Figure 4

HEMISPHERICAL FREE — FIELD SOUND ENVIRONMENT

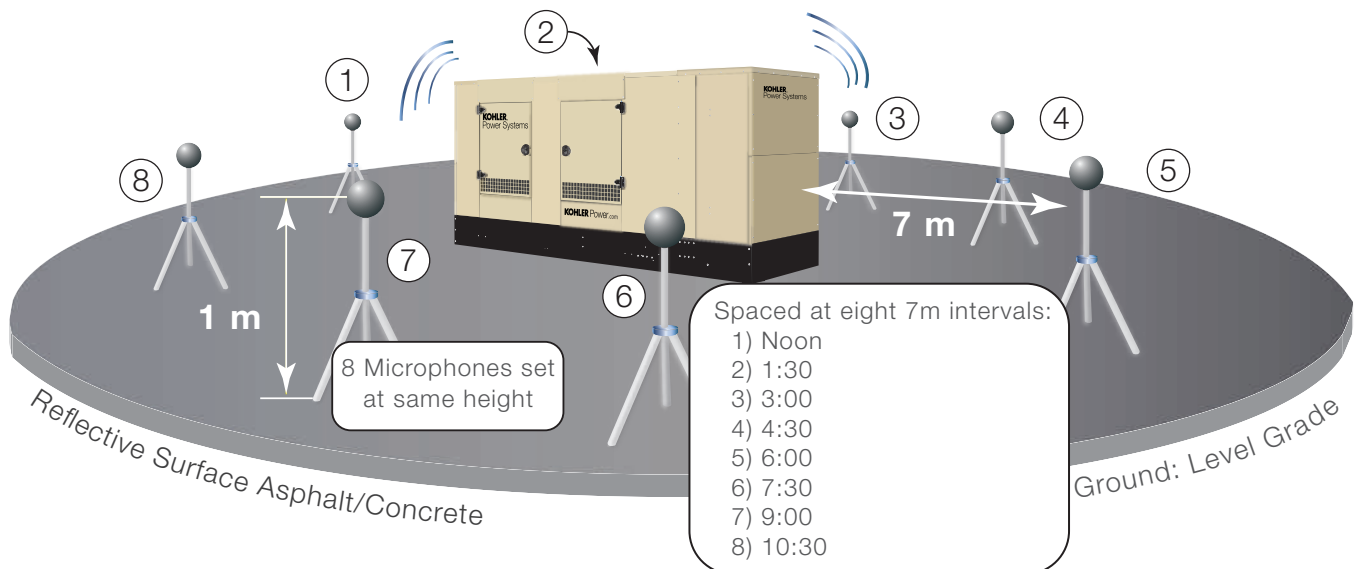

MEASURING SOUND OF OPEN SET

Open generator sets with a mounted silencer are tested similar to enclosed generators. *Figure 4.*

MEASURING OPEN SET SOUND & ISOLATED EXHAUST

As many interior installations are an open generator set with the exhaust piped to an externally mounted muffler, sound measurements of an open set, per *Figure 4*, are taken, but with the muffler remotely mounted to ensure negligible exhaust noise emission within the test area.

Customers purchasing open units for installation within a building use these noise measurements to determine if additional attenuation is required. In some cases, even with a remotely mounted silencer, additional engine room attenuation is required to be within the specified noise limit.

MEASURING RAW EXHAUST SOUND

Raw exhaust refers specifically, and only, to the noise emitted by the engine exhaust system when no silencer is present. It does not include noise from other sources on the generator set.

Sound data, at one location, is collected at the end of a straight pipe connected directly to the engine exhaust as indicated in *Figure 5*. The measurement is taken at a close distance of 1 meter (3.3 ft.) to ensure only the exhaust noise is significant in the noise measured.

Figure 5 Raw Exhaust Sound Test

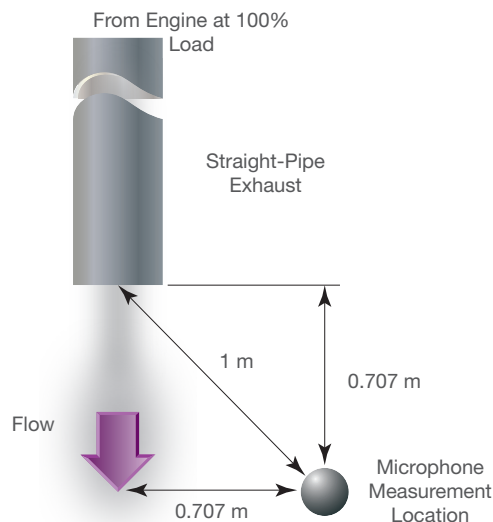

Close proximity raw exhaust measurements are equally useful in determining silencers for mounting to, or remotely from, the generator. The raw exhaust sound data per *Figure 6* is provided as engineering data for use in silencer design or selection.

Figure 6

| Sound Pressure Levels dB(A) – Raw Exhaust (No Silencer) | | | | | | | | | |
|---|----------------------------|-------|-------|-------|-------|-------|-------|---------------|-------|
| Measurement Position | Octave Band Frequency (Hz) | | | | | | | Overall Level | |
| | 63 | 125 | 250 | 500 | 1000 | 2000 | 4000 | | 8000 |
| Pipe End | 93.1 | 106.6 | 116.8 | 120.4 | 121.5 | 122.4 | 122.4 | 123.0 | 129.7 |

IMPORTANCE OF SOUND FOR POWER GENERATION

CALCULATING THE SOUND AT VARYING DISTANCES FROM SOURCE

While standardized sound measurements taken by the manufacturer are set at 7 meters (27 ft), frequently, to meet sound ordinances at any particular location, sound readings have to be taken at varying distances.

When there are no reflecting surfaces to amplify the noise of the generator set, the lot line sound (distance from noise source) reduces by 6 dB(A) each time the distance is doubled, or the square of the distance from the source *Figure 7*. This formula assumes the space to the lot line sound source is free and clear.

Figure 7

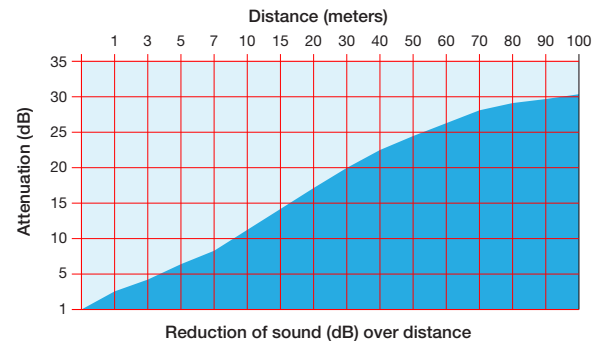

MECHANICAL NOISE VERSUS EXHAUST NOISE

A generator system is a complex piece of equipment made up of many moving parts. Movement of each part creates vibration, which then interacts with the air to create sound at various frequencies. *Figure 6* details various noise sources generated by mechanical vibration measured in dB(A) at 1 meter.

AMBIENT NOISE AND OTHER STRUCTURES AROUND A GENERATOR ENCLOSURE

While testing enclosed generator systems in a free-field environment away from surrounding structures provides an accurate measurement of sound pressure received at a set distance, the actual sound pressure perceived by the ear will vary from location to location.

Many locations will be in a reverberant field where sound pressure can be amplified as it is reflected from a building or other obstacle.

To meet local ordinances, sound measurements may also have to be taken at the final location.

Figure 6

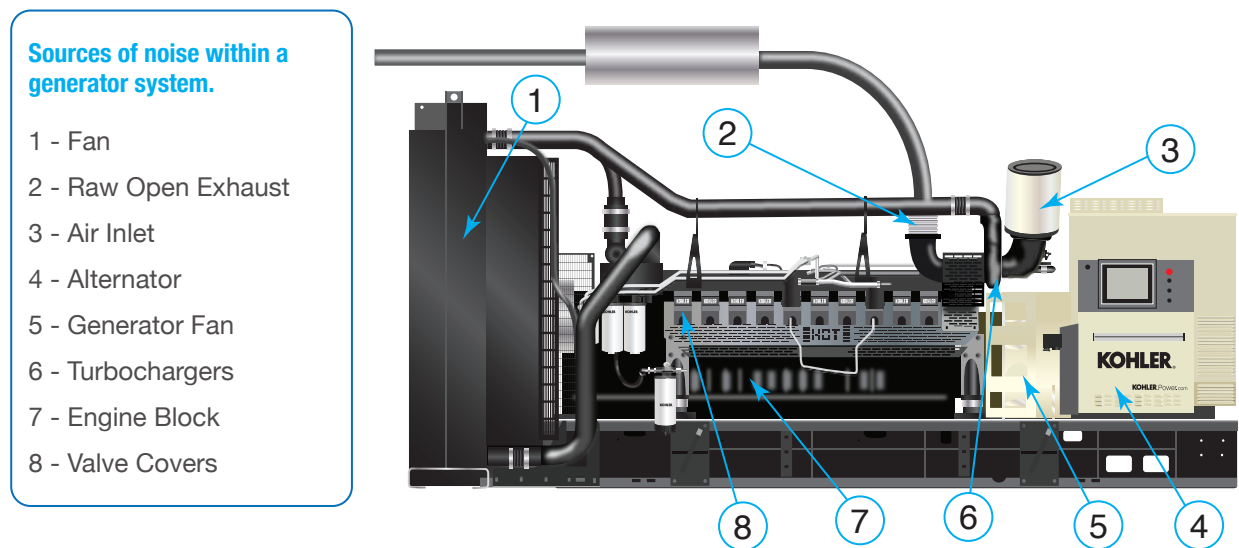

DEFINING ENCLOSURE SOUND LEVELS

TYPES OF ENCLOSURE

The majority of generator systems installed and/or used in an outdoor location, whether mobile or fixed, are enclosed. All types of enclosures will limit the noise sources to some degree, but the final degree of audible sound permitted will dictate the type of enclosure. Enclosures usually fall into three categories:

- Weather-protective enclosure
- Sound attenuated enclosure to level 1 and 2 (dB(A) reduction)
- Custom enclosures – level 3 and above

WEATHER-PROTECTIVE ENCLOSURES

A weather protective enclosure, usually sheet steel or aluminum, provides some limited reduction in noise. Vibration isolators between major components provide further attenuation by reducing operational vibration that creates noise. Redirection of air before it exits the sound enclosure also helps reduce sound levels.

When the applicable installation noise ordinances are no lower than 80 dB(A) at 7 meters, consideration should be given to the exhaust silencer before adding further sound attenuation material.

See *Figure 8*. This chart details the comparative reductions in exhaust noise for each silencer type. However, final ambient noise will be influenced by the characteristics of the engine and silencer placement.

Figure 8

| Generator Silencer Grades | | |
|---------------------------|---------------------------------|------------------------------|
| Silencer Type | Exhaust Noise Reduction, dB(A)* | Site Attenuation Requirement |
| Hospital | 32 – 42 | Very High |
| Critical | 25 – 35 | High |
| Residential | 18 – 25 | Medium |
| Industrial | 12 – 18 | Low – Medium |

*Listed exhaust noise reductions are typical; actual performance may vary.

Figure 9

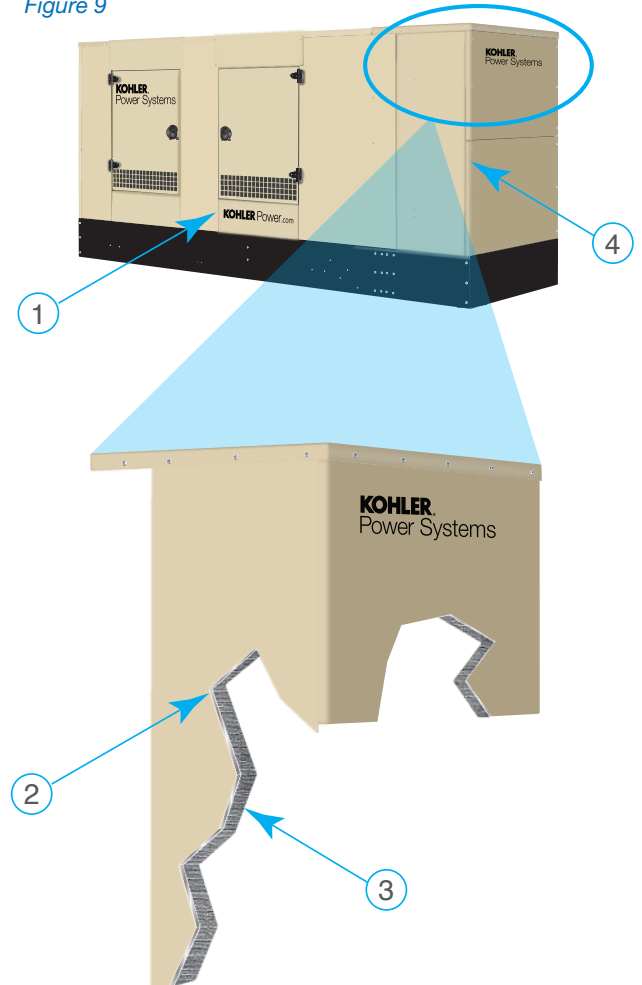

ENCLOSURES LEVEL-1 AND LEVEL-2 ATTENUATION

- 1 - Typical sheet metal level-1 enclosure provides limited noise reduction
- 2 - Sheet metal enclosure
- 3 - To attain level-2, sides are lined with sound absorbing material
- 4 - Silencer in enclosure will be critical grade for level 2

SOUND ATTENUATED ENCLOSURE LEVEL 1 AND 2

When a basic weather-protective enclosure has insufficient attenuation to meet site noise ordinances, the next stage is to line the inside panels of the enclosure sides with sound absorbing material. A level 1 enclosure will reduce noise in the order of 3 dB(A). See [Figure 9](#) for details.

Additional absorbing material over louvers through which air flows in and out will achieve level 2 noise reduction of around 10 dB(A). It is common to apply this type of enclosure in critical environments such as healthcare facilities and populated work areas. Also, levels 1 and 2 enclosures are usually fitted with residential or critical exhaust silencers.

CUSTOM ENCLOSURES LEVEL 3 AND ABOVE

Some generator systems, such as those supplying power for film production, live concerts, or nighttime use, have to meet significantly lower

noise levels. In these applications, the enclosure will be to level 3 and above reduction, with at least a 14 dB(A) drop in measured sound. (Note: Sound is measured on a logarithmic scale, this is significant attenuation.)

Sound pressure is transmitted through air. The further the air travels through outlets lined with noise-absorbing material, the greater the attenuation before air leaves the enclosure. However, air is used for combustion and cooling, any redirecting has to avoid restriction to avoid overheating. The solution in a level 3 type of enclosure is not to restrict cooling but redirect air via sound outlets covered in sound absorbent material before it exits the enclosure.

With this technology, when applied with increased vibration isolation and a higher-grade exhaust silencer, it is possible to reduce noise emitted from the enclosure to a level that one can have a discussion next to the generator running on full load. See [Figure 10](#). The same type of technology can be applied to open sets installed within a building.

Figure 10

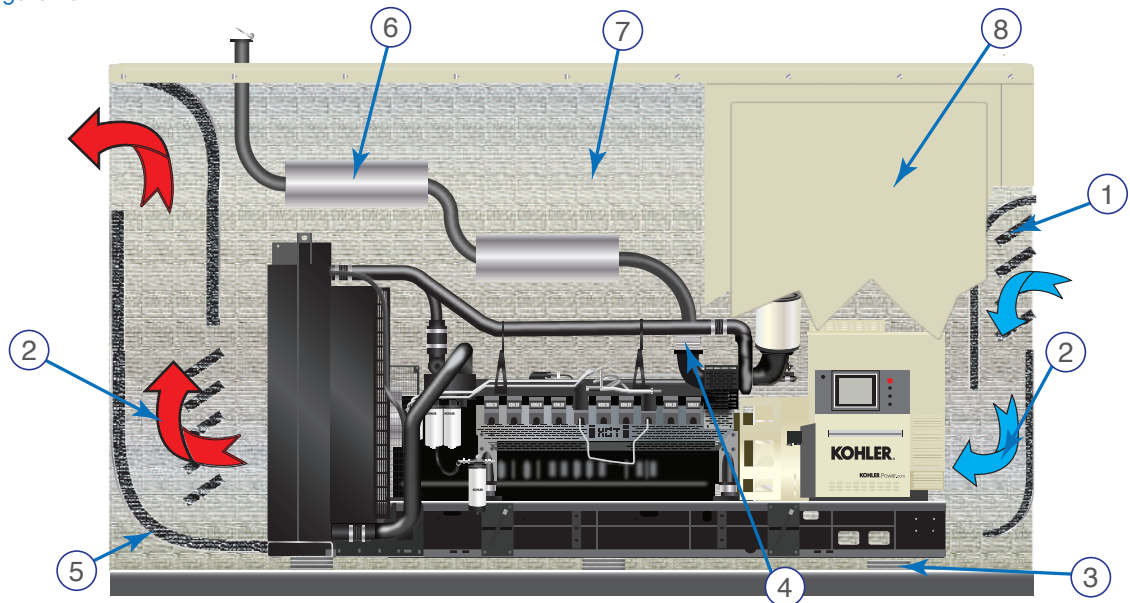

SAMPLE DESIGN FEATURES TO ATTAIN LEVEL-3 SOUND ATTENUATION

- | | |
|---|---|
| 1 - Sound attenuated louvers | 5 - Noise absorbent lining on ducting |
| 2 - Ducted air redirected at right angles reduces noise | 6 - Secondary silencer |
| 3 - Spring vibration isolators with rubber pads | 7 - Noise absorbent lining on internal siding |
| 4 - Flexible exhaust bellows | 8 - Sheet metal enclosure |

ABOUT KOHLER

A global force in power solutions since 1920, Kohler is committed to reliable, intelligent products; purposeful engineering and responsive after-sale support. Kohler and SDMO are among the world's largest manufacturers of industrial generators. The companies have a combined 150 years experience in industrial power and benefit from global R&D, manufacturing, sales, service and distribution integration.