

Service Parts

Residential/Commercial Generator Sets

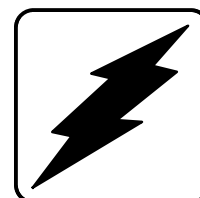

Models:

8.5/11RMY

8.5/12RES

12TRES

KOHLER[®]
Power Systems

ISO 9001
KOHLER
POWER SYSTEMS
NATIONALLY REGISTERED

TP-5868 8/15m

Common Replacement Parts

Figure 1 identifies 2000-hour common replacement parts for your generator set. Refer to the groups on the following pages for a complete list of maintenance and service parts.

Description	Part Number	Quantity			
		8.5RMY	8.5RES	11RMY	12RES
Element, air filter	24 083 08-S	1	1		
Element, air filter	24 083 09-S			1	1
Filter, breather	24 050 01-S	8	8	8	8
Filter, oil	12 050 01-S	40	40	40	40
Fuse, 10 A, 250 V	223316	5	5	5	5
Fuse, 20 A, 250 V	292937		5		5
Kit, speed sensor	241927	1		1	
Sensor, temperature (oil)	GM28823		1		1
Kit, voltage regulator	F-228605	1		1	
Lamp, 14 V, .33 W	269373	5		5	
PCB assembly (relay controller)	GM10064	1		1	
PCB assy, relay board 12V	GM29671		1		1
Pre-cleaner	24 083 02-S	8	8		
Pre-cleaner	24 083 05-S			8	8
Spark plug	12 132 02-S	2	2	2	2
Spark plug (RFI)	25 132 14-S		2		

Figure 1 2000-Hour Replacement Parts

Figure 2 identifies paint available from the factory.

Color Description	Part Number		
	Touch-up Bottle	Spray Can	Gallon
Cream Beige	N/A	GM71383	GM71387
Sage Green	GM50484	N/A	N/A
Textured KCB (Cream Beige)	GM83001	GM82834	GM82835
Textured Black	GM83002	GM82836	N/A
Textured Cashmere	GM84772	GM84771	N/A

Figure 2 Factory-Available Paint

Table of Contents

Introduction	5
Numbering System Significance	5
Illustrations	5
How to Find Part Numbers	5
Hardware References	5
8.5RMY & 11RMY Specification Number Index	6
8.5RES, 12RES, & 12TES Specification Number Index	8
Group 1: Crankshaft	10
Group 2: Crankcase	11
Group 3: Lubrication	12
Group 4: Cylinder Head/Valve/Breather	14
Group 5: Ignition/Electrical	16
Group 6: Blower Housing and Baffles	17
Group 7: Starting System	18
Group 8: Carburetor	19
Group 9: Engine Controls	20
Group 10: Air Intake/Filtration	21
Group 11: Exhaust	22
Group 12: Gasket Set	22
Group 103: Fuel System	23
Group 105: Engine	26
Group 107: Nameplate and Decals	28
Group 109: Skid and Plant Mounting	30
Group 112: Starter	32
Group 116: Exhaust	34
Group 201: Generator and Mounting	36
Group 301: Controller and Mounting	38
8.5RMY & 11RMY	38
8.5RES & 12RES ADC-2100 Controller	40
8.5RES & 12RES ADC-RES Controller	42
12TRES 3 Phase Controller	44
Group 501: Housing and Mounting	46
8.5RMY & 11RMY, Variation 1	46
8.5RMY & 11RMY, Variations 4, GR9, 29-10	48
8.5RES & 12RES	50
12TRES 3 Phase Controller	56
Group 701: Literature	58
Kit Parts List	57
Appendix A. Abbreviations	62
Appendix B. Common Hardware Application Guidelines	64
Appendix C. General Torque Specifications	65
Appendix D. Common Hardware Identification	66
Appendix E. Common Hardware List	67

Notes

Introduction

This manual lists service replacement parts for 8.5/11RMY, 8.5/12RES, and 12TRES generator sets.

Information in this publication represents data available at the time of print. Kohler Co. reserves the right to change this publication and the products represented without notice and without any obligation or liability whatsoever.

This manual includes the following main sections:

Table of Contents. Lists the sections of the manual.

Introduction (and other information sections). Contains introductory material about part numbers, illustrations, and hardware.

Specification Number Index. Lists the generator set specs and groups.

Group Parts Lists. List the part numbers of parts in the groups.

Kit Sections. List modules and accessories and their parts.

Appendices. Include Abbreviations, Common Hardware Application Guidelines, General Torque Specifications, Common Hardware Identification, and Common Hardware List.

Numbering System Significance

This manual uses the following numbering systems:

Specification Number. The product identification number located on the generator set nameplate. Specification numbers break down into groups.

Group Number. A unique number representing a parts group needed to assemble a generator set function. For example, Group 101 is the Air Intake group.

Variation or Module Number. A group might have several variations. Each variation performs the same function with different parts lists. For example, a 50 Hz generator alternator and a 60 Hz generator alternator both perform the same function; however, with different parts. Each difference requires a group variation or module number.

Part Number. The part number identifies an individual assembly, subassembly, component, or accessory kit.

Illustrations

Illustrations (or exploded-view drawings) best representing the widest range of variations accompany most groups in this manual. Illustrations do not depict all details and may not show all parts. Do not use illustrations for assembly or disassembly.

How to Find Part Numbers

Use the following steps to locate a service replacement part.

1. Locate the generator set nameplate to **identify the generator set spec number**.
2. Locate a second generator set nameplate listing accessories to **identify installed modules**. On some models the accessory nameplate is mounted inside the generator junction box.
3. **Turn to the Specification Number Index**. The first column lists the generator set spec numbers. The headings identify the groups of parts that make up the generator set.
4. **Identify the group** most likely to include the service part number.
5. **Find the group variation number** at the intersection of the spec number row and the group column. Note the variation number.
6. **Page forward to locate the group** identified in step 4 or find the appropriate page in the Table of Contents.
7. **Find the part on the illustration** and note the item number of the part or **find the part description in the parts list**.
8. Select **the part number that corresponds to your group variation**. The first column lists the illustration item number. Find the variation identified in the Specification Number Index or the module number found on the generator set nameplate in the appropriate column on the right side of the parts list table. Find the quantity used at the intersection of the item number row and the variation column. A blank space at the intersection means the variation/module does not use that part number.

Hardware References

Many common hardware items do not appear in parts manuals or will appear as common hardware entries. A common hardware entry lists the size of the hardware. For example, an item that appears as "Hardware, 3/8-16" in the text means that the piece is 3/8-16 size. Obtain common hardware locally or, if contacting the factory, use the Common Hardware List in the appendix to identify the common hardware part number and specifications. See Common Hardware Application Guidelines in the appendix for mating hardware instructions.

Some hardware items require a specific size or some other characteristic. In that case, use the part number listed in the text.

When replacing hardware, do not substitute inferior grade hardware. Replacement hardware grade should be equal to or better than the grade of the manufacturer's original hardware. Use the Common Hardware List in the appendix to identify the common hardware hardness.

8.5RMY & 11RMY Specification Number Index

Group Title	<div style="display: flex; justify-content: space-around;"> <div style="writing-mode: vertical-rl; transform: rotate(180deg);">Crankshaft</div> <div style="writing-mode: vertical-rl; transform: rotate(180deg);">Crankcase</div> <div style="writing-mode: vertical-rl; transform: rotate(180deg);">Oil Pan/Lubrication</div> <div style="writing-mode: vertical-rl; transform: rotate(180deg);">Cylinder Head/Valve/Breather</div> <div style="writing-mode: vertical-rl; transform: rotate(180deg);">Ignition/Electrical</div> <div style="writing-mode: vertical-rl; transform: rotate(180deg);">Blower Housing & Baffles</div> <div style="writing-mode: vertical-rl; transform: rotate(180deg);">Starting System</div> <div style="writing-mode: vertical-rl; transform: rotate(180deg);">Carburetor</div> <div style="writing-mode: vertical-rl; transform: rotate(180deg);">Engine Controls</div> <div style="writing-mode: vertical-rl; transform: rotate(180deg);">Air Intake/Filtration</div> <div style="writing-mode: vertical-rl; transform: rotate(180deg);">Exhaust</div> <div style="writing-mode: vertical-rl; transform: rotate(180deg);">Gasket Set</div> </div>											
Group No.	1	2	3	4	5	6	7	8	9	10	11	12
Spec No.	Variation Number											

8.5RMY												
PA-195007	35	92	337	34	347	224	13	214	98	20	90	1
PA-195016	35	92	337	34	347	224	13	214	98	20	90	1
PA-195017	35	92	337	34	347	224	13	214	98	20	90	1
PA-195021	35	92	337	34	347	224	13	214	98	20	90	1
PA-195025	35	92	337	34	347	224	13	214	98	20	90	1
GM16902-GA1	35	92	337	34	347	224	13	214	98	20	90	1
GM24829-GA1	35	92	337	268	347	224	13	214	98	20	90	1
11RMY												
PA-195008	35	146	376	96	348	225	13	342	98	47	90	1
PA-195018	35	146	376	96	348	225	13	342	98	47	90	1
PA-195019	35	146	376	96	348	225	13	342	98	47	90	1
PA-195022	35	146	376	96	348	225	13	342	98	47	90	1
PA-195026	35	146	376	96	348	225	13	342	98	47	90	1
GM16902-GA2	35	146	376	96	348	225	13	342	98	47	90	1
GM24829-GA2	35	146	376	96	348	225	13	342	98	47	90	1

8.5RMY & 11RMY Specification Number Index

Group Title	<i>Fuel System</i>	<i>Engine</i>	<i>Nameplate and Decals</i>	<i>Skid and Plant Mounting</i>	<i>Starter</i>	<i>Exhaust</i>	<i>Generator and Mounting</i>	<i>Controller and Mounting</i>	<i>Housing and Mounting</i>	<i>Literature</i>
Group No.	103	105	107	109	112	116	201	301	501	701
Spec No.	Variation Number									

8.5RMY										
PA-195007	3	2	4	3	4	3	5	4	1	7
PA-195016	3	2	12	3	4	3	5	4	1	7
PA-195017	3	2	12	3	4	3	5	4	1	7
PA-195021	8	5	13	6	6	6	10	9	4	7
PA-195025	8	5	14	6	6	6	10	10	4	7
GM16902-GA1	GR3	GR1	GR10	GR5	GR1	GR6	GR7	GR8	GR9	11
GM24829-GA1	29-3	29-1	29-5	29-6	29-1	29-7	29-8	29-11	29-10	11
11RMY										
PA-195008	7	3	4	3	4	3	5	5	1	7
PA-195018	7	3	12	3	4	3	5	5	1	7
PA-195019	7	3	12	3	4	3	5	5	1	7
PA-195022	8	6	13	6	6	6	10	9	4	9
PA-195026	8	6	14	6	6	6	10	10	4	9
GM16902-GA2	GR3	GR2	GR4	GR5	GR1	GR6	GR7	GR8	GR9	11
GM24829-GA2	29-3	29-2	29-4	29-6	29-2	29-7	29-8	29-9	29-10	11

8.5RES, 12RES, & 12TRES Specification Number Index

Group Title												
	<i>Crankshaft</i>	<i>Crankcase</i>	<i>Oil Pan/Lubrication</i>	<i>Cylinder Head/Valve/Breather</i>	<i>Ignition/Electrical</i>	<i>Blower Housing & Baffles</i>	<i>Starting System</i>	<i>Carburetor</i>	<i>Engine Controls</i>	<i>Air Intake/Filtration</i>	<i>Exhaust</i>	<i>Gasket Set</i>
Group No.	1	2	3	4	5	6	7	8	9	10	11	12
Spec No.	Variation Number											

8.5RES												
GM29253-GA1	35	193	528	34	695	352	13	559	98	20	90	1
GM29253-GA3	35	193	528	34	695	352	13	559	98	20	90	1
GM29253-GA6	35	193	528	34	695	352	13	559	98	20	90	1
GM29253-GA8	35	193	528	34	695	352	13	559	98	20	90	1
GM29253-GA15	35	193	528	34	695	352	13	559	98	20	90	1
GM29253-GA17	35	193	528	34	695	352	13	559	98	20	90	1
GM29253-GA24	35	193	528	34	1058	352	13	559	98	20	90	1
GM29253-GA25	35	193	528	34	1058	352	13	559	98	20	90	1
GM29253-GA33	35	193	528	34	1058	352	13	559	98	20	90	1
GM29253-GA34	35	193	528	34	1058	352	13	559	98	20	90	1
12RES												
GM29253-GA2	35	192	528	273	689	350	13	558	98	47	90	1
GM29253-GA4	35	192	528	273	689	350	13	558	98	47	90	1
GM29253-GA5	35	192	528	273	689	350	13	558	98	47	90	1
GM29253-GA7	35	192	528	273	689	350	13	558	98	47	90	1
GM29253-GA9	35	192	528	273	689	350	13	558	98	47	90	1
GM29253-GA10	35	192	528	273	689	350	13	558	98	47	90	1
GM29253-GA16	35	192	528	273	689	350	13	558	98	47	90	1
GM29253-GA18	35	192	528	273	689	350	13	558	98	47	90	1
GM29253-GA19	35	192	528	273	689	350	13	558	98	47	90	1
GM29253-GA28	35	192	528	273	689	350	13	558	98	47	90	1
GM29253-GA29	35	192	528	273	689	350	13	558	98	47	90	1
GM29253-GA30	35	192	528	273	689	350	13	558	98	47	90	1
GM29253-GA37	35	192	528	273	689	350	13	558	98	47	90	1
GM29253-GA38	35	192	528	273	689	350	13	558	98	47	90	1
12TRES												
GM29253-GA22	35	192	528	273	689	350	13	558	98	47	90	1

8.5RES, 12RES, & 12TRES Specification Number Index

Group Title	<i>Fuel System</i>	<i>Engine</i>	<i>Nameplate and Decals</i>	<i>Skid and Plant Mounting</i>	<i>Starter</i>	<i>Exhaust</i>	<i>Generator and Mounting</i>	<i>Controller and Mounting</i>	<i>Housing and Mounting</i>	<i>Literature</i>
	Group No.	103	105	107	109	112	116	201	301	501
Spec No.	Variation Number									

8.5RES										
GM29253-GA1	53-3	53-1	53-5	53-13	53-1	53-1	53-7	53-8	53-9	13
GM29253-GA3	53-17	53-1	53-11	53-13	53-1	53-1	53-7	53-19	53-9	14
GM29253-GA6	53-15	53-1	53-12	53-13	53-1	53-1	53-7	53-14	53-9	13
GM29253-GA8	53-17	53-1	53-12	53-13	53-1	53-1	53-7	53-19	53-9	20
GM29253-GA15	53-17	53-1	*	53-13	53-1	53-1	53-7	53-19	*	14
GM29253-GA17	53-17	53-1	*	53-13	53-1	53-1	53-7	53-19	*	20
GM29253-GA24	53-17	53-30	*	53-13	53-1	53-1	53-7	53-19	*	20
GM29253-GA25	53-17	53-30	*	53-13	53-1	53-1	53-7	53-19	*	14
GM29253-GA33	53-17	53-30	*	53-13	53-1	53-1	53-7	53-38	*	49
GM29253-GA34	53-17	53-30	*	53-13	53-1	53-1	53-7	53-38	*	14
12RES										
GM29253-GA2	53-3	53-2	53-5	53-13	53-2	53-1	53-7	53-8	53-9	13
GM29253-GA4	53-17	53-2	53-10	53-13	53-2	53-1	53-7	53-8	53-9	14
GM29253-GA5	53-15	53-2	53-5	53-13	53-2	53-1	53-7	53-14	53-9	13
GM29253-GA7	53-15	53-2	53-5	53-13	53-2	53-1	53-7	53-14	53-9	13
GM29253-GA9	53-17	53-2	53-5	53-13	53-2	53-1	53-7	53-20	53-9	20
GM29253-GA10	53-17	53-2	53-5	53-13	53-2	53-1	53-7	53-20	53-9	20
GM29253-GA16	53-17	53-2	*	53-13	53-2	53-1	53-7	53-20	*	14
GM29253-GA18	53-17	53-2	*	53-13	53-2	53-1	53-7	53-20	*	20
GM29253-GA19	53-17	53-2	*	53-13	53-2	53-1	53-7	53-20	*	20
GM29253-GA28	53-17	53-2	*	53-13	53-2	53-1	53-7	53-35	*	14
GM29253-GA29	53-17	53-2	*	53-13	53-2	53-1	53-7	53-35	*	49
GM29253-GA30	53-17	53-2	*	53-13	53-2	53-1	53-7	53-35	*	49
GM29253-GA37	53-41	53-2	*	53-13	53-2	53-1	53-7	53-35	*	92
GM29253-GA38	53-41	53-2	*	53-13	53-2	53-1	53-7	53-35	*	92
12TRES										
GM29253-GA22	53-17	53-2	*	53-13	53-2	53-1	53-32	53-28	*	43

* Configured group. Refer to the generator set nameplate for the module number.
Turn to the respective group on the following pages for parts breakdowns.

Group 1: Crankshaft

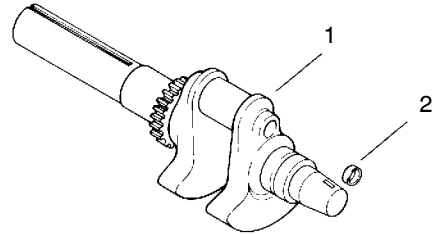

A358191_7

Item	Part Number	Description	Qty.
			Variation No.
1	24 014 106-S	Crankshaft assembly	1
2	52 139 09	Plug, cap	1

Group 2: Crankcase

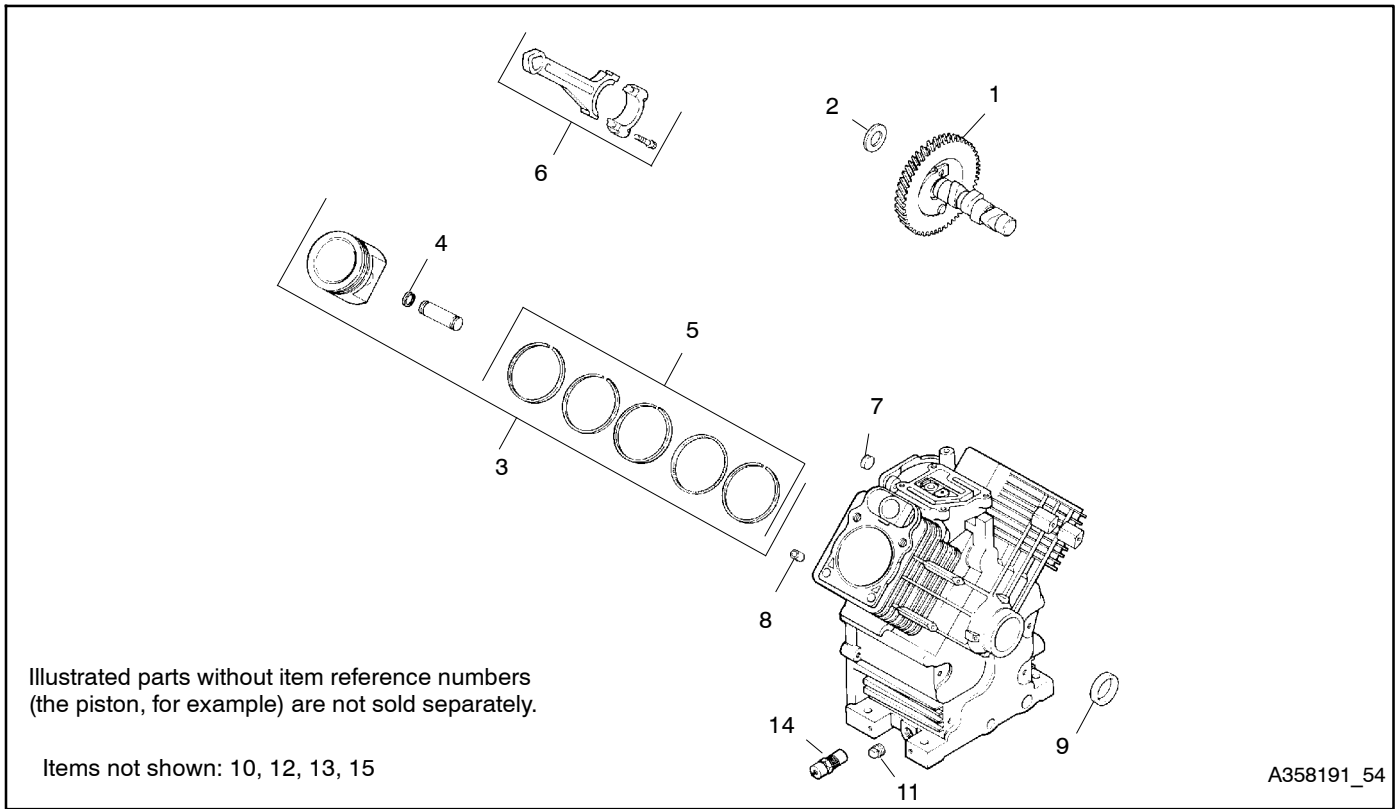

Item	Part Number	Description	Qty.				
			Variation No.				
			92	146	181	192	193
1	24 012 10-S	Camshaft	1	1			1
1	24 012 18-S	Camshaft			1	1	
2	12 422 09-S	Shim, camshaft, red, 0.03125-0.03275	AR	AR	AR	AR	AR
2	12 422 13-S	Shim, camshaft, black, 0.0395-0.04075	AR	AR	AR	AR	AR
2	12 422 07-S	Shim, camshaft, white, 0.02725-0.02875	AR	AR	AR	AR	AR
2	12 422 08-S	Shim, camshaft, blue, 0.02925-0.03075	AR	AR	AR	AR	AR
2	12 422 10-S	Shim, camshaft, yellow, 0.03325-0.03475	AR	AR	AR	AR	AR
2	12 422 11-S	Shim, camshaft, green, 0.03525-0.0367	AR	AR	AR	AR	AR
2	12 422 12-S	Shim, camshaft, gray, 0.03725-0.0387	AR	AR	AR	AR	AR
3	24 874 17-S	Piston w/ring set, standard	2				2
3	24 874 08-S	Piston w/ring set, standard		2	2	2	
3	24 874 18-S	Piston w/ring set, 0.25 OS	2				2
3	24 874 16-S	Piston w/ring set, 0.08 OS		2	2	2	
3	24 874 14-S	Piston w/ring set, 0.08 OS					2
3	24 874 19-S	Piston w/ring set, 0.50 OS					2
4	24 018 01-S	Retainer, piston pin	4	4	4	4	4
5	24 108 01-S	Ring set, standard	2				
5	24 108 05-S	Ring set, standard		2	2		
5	24 108 11-S	Ring set, standard					2
5	24 108 12-S	Ring set, 0.25	2				
5	24 108 19-S	Ring set, 0.50	2				
6	24 067 13-S	Rod, connecting, standard	2	2	2	2	2
6	24 067 14-S	Rod, connecting, 0.25	2	2	2	2	2
7	52 139 09-S	Plug, cup	1	1	1	1	1
8	24 380 13-S	Dowel, locating	6	6	6	6	6
9	24 032 01-S	Seal, oil front	1	1	1	1	1
10	25 139 57-S	Plug, cup (not shown)	1	1	1	1	1
10	25 139 28-S	Plug, cup (not shown)				1	1
11	X-75-10	Plug, solid square head, 3/8 in., NPTF	2				
12	24 522 162	Short block (not shown)	1				
13	24 782 17	Miniblock (not shown)	1				1
13	24 782 33	Miniblock (not shown)		1	1	1	
14	24 418 02	Sensor, oil temperature	1	1	1		
14	GM28823	Sensor, oil temperature				1	1
15	25 158 12-S	Bushing, reducing (not shown)				1	1

AR as required

Group 3: Lubrication

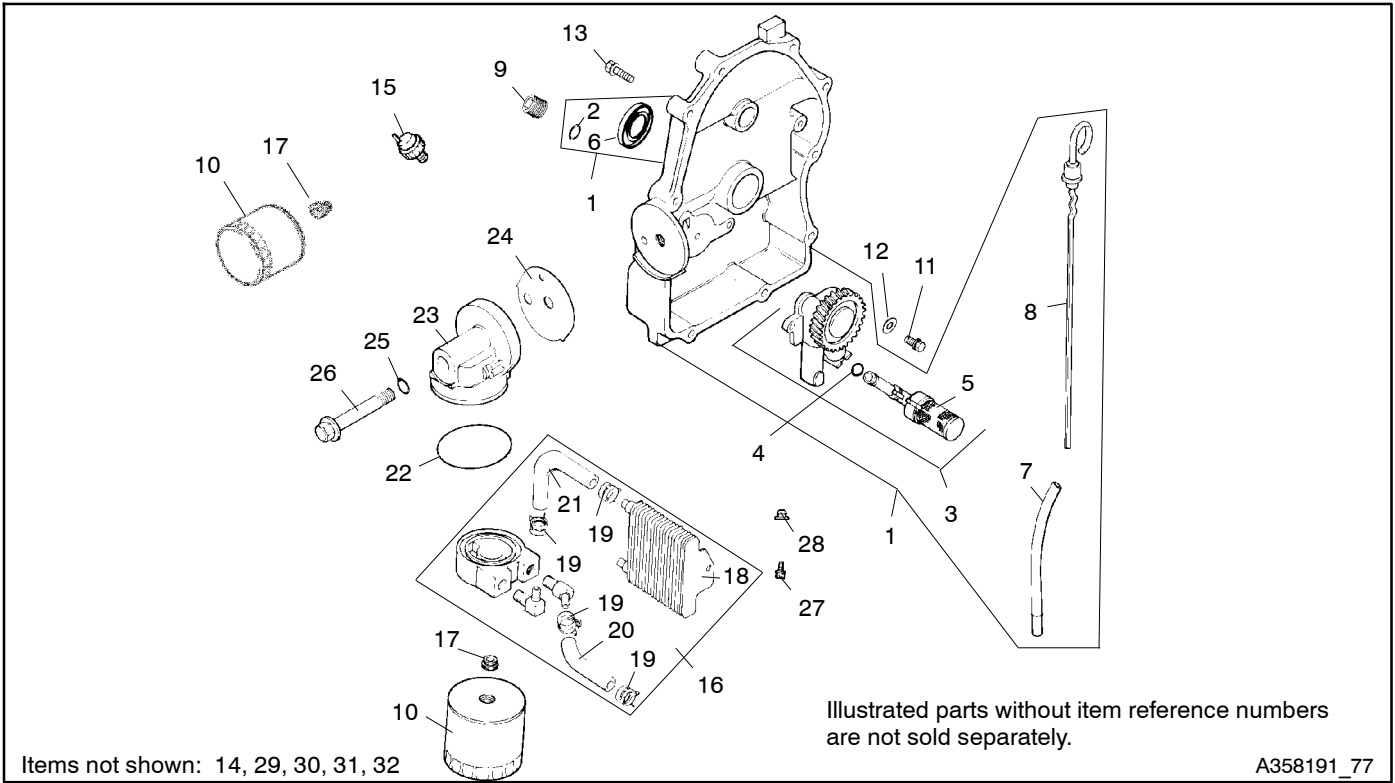

Group 3: Lubrication

Item	Part Number	Description	Qty.			
			Variation No.			
			77	376	337	528
1	24 009 92-S	Plate, closure	1	1	1	1
2	24 153 08-S	O-ring	1	1	1	1
3	24 393 37-S	Oil pump assembly (includes 4 and 5)	1	1	1	1
4	24 153 01-S	O-ring, oil pickup	1	1	1	1
5	24 381 04-S	Pickup, oil	1	1	1	1
6	52 032 08-S	Seal, oil	1	1	1	1
7	24 755 121-S	Kit, dipstick/dipstick tubes	1			
8	24 755 121-S	Dipstick	1			
8	24 038 10-S	Dipstick		1	1	1
9	X-75-23	Plug, Allen head, 1/8 in.	2			
9	25 139 60-S	Plug, pipe, 1/8 NPTF			1	1
10	12 050 01-S	Filter, oil	1	1	1	1
11	M-645025-S	Screw, hex flange, M6 x 1 x 25	2	2	2	2
12	M-631005-S	Washer, plain, 6mm	2	2	2	2
13	24 086 16-S	Screw, hex flange, M8 x 1.25 x 45	9	9	9	9
14	24 086 17-S	Screw, hex flange, M8 x 1.25 x 45 (not shown)	1	1	1	1
15	25 099 24-S	Switch, oil pressure	1	1	1	
15	25 099 26-S	Switch, oil pressure				1
16	24 755 120-S	Kit, oil cooler	1	1	1	1
17	24 136 05-S	Nipple, oil filter	1	1	1	1
18	24 594 10-S	Cooler, oil assembly	1	1		
19	24 237 03	Clamp, hose	4			
19	24 237 10	Clamp, hose		4		
20	24 326 16	Hose, oil, 97 mm	1			
21	24 326 17	Hose, oil, 140 mm	1			
21	24 326 15	Hose		2		
22	24 153 21-S	O-ring	1	1	1	1
23	24 029 01	Adapter, oil filter (see note)	1			
24	24 041 29	Gasket, oil filter adapter	1			
25	24 153 01	O-ring	1			
26	24 211 01	Bolt, oil filter adapter	1			
27	24 086 12-S	Screw, hex cap, M6 x 1.7 x 18	2	2	2	2
28	24 100 01-S	Nut, plastic	2	2	2	2
29	24 146 11	Plate, backing, #2 side (not shown)	1	1		
30	41 037 10	Decal, write-on nameplate (not shown)	1	1		
31	25 113 25-S	Decal, oil sentry (not shown)	1	1		
32	25 113 05-S	Decal, oil cooler (not shown)	1	1		

Note: Engine model CH20 (specification 64607) used an oil filter adapter (variation 77) before changing to variation 337.

Group 4: Cylinder Head/Valve/Breather

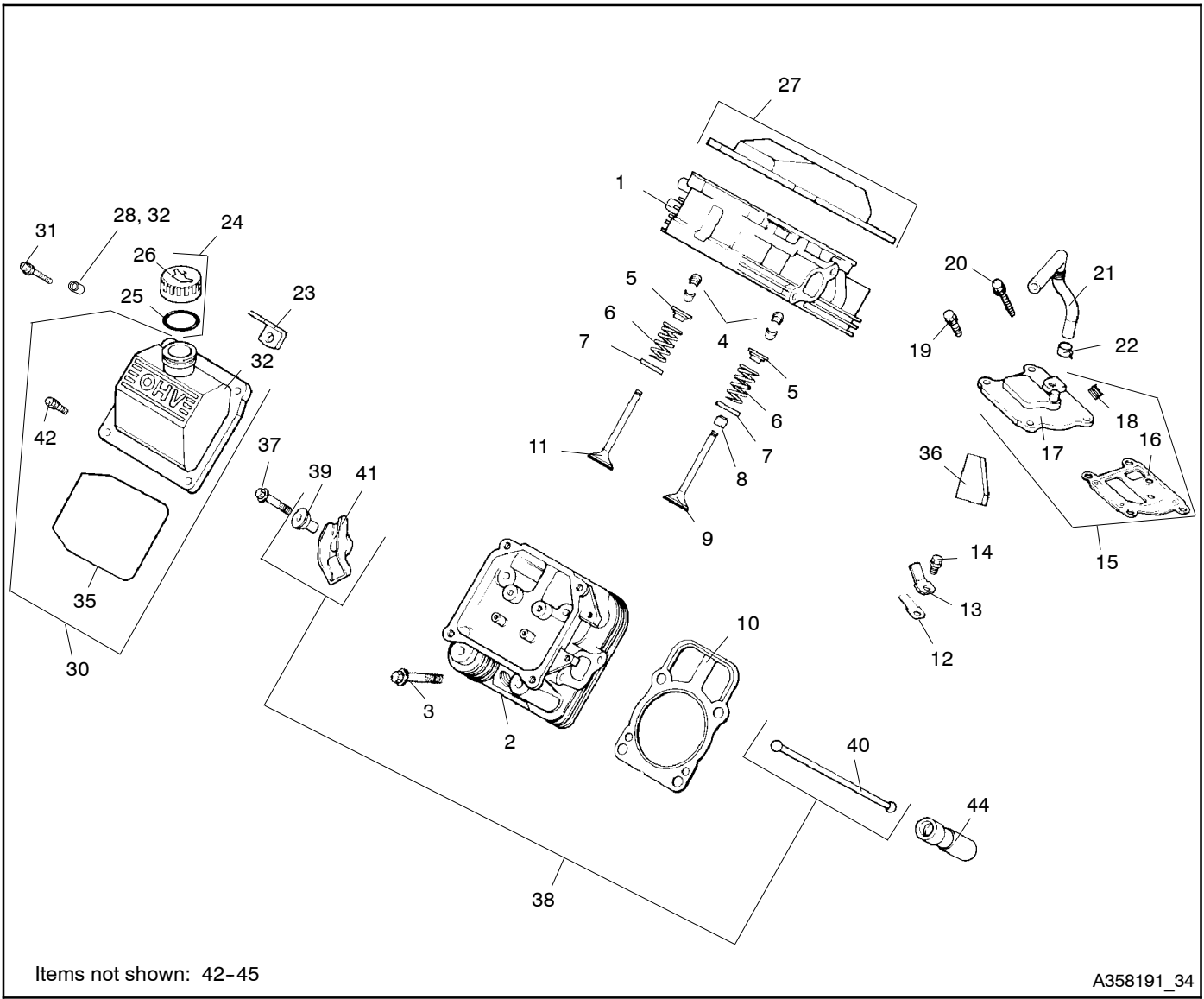

Group 4: Cylinder Head/Valve/Breather

Item	Part Number	Description	Qty.			
			Variation No.			
			34	96	268	273
1	24 318 68-S	Head assembly, #1 cylinder	1			
1	24 318 65-S	Head assembly, #1 cylinder		1		
1	24 318 88-S	Head assembly, #1 cylinder			1	
1	24 318 92-S	Head assembly, #1 cylinder				1
2	24 318 71-S	Head assembly, #2 cylinder	1			
2	24 318 66-S	Head assembly, #2 cylinder		1		
2	24 318 94-S	Head assembly, #2 cylinder				1
2	24 318 90-S	Head assembly, #2 cylinder			1	
3	12 086 16	Screw, hex flange, M10 x 1.5 x 90	8	8	8	
4	12 755 03-S	Kit, retainer	4	4	4	8
5	12 173 01-S	Cap, valve spring	4	4	4	4
6	24 089 02-S	Spring, valve	4	4	4	4
7	235011-S	Retainer, spring	4	4	4	4
8	66 032 05-S	Seal, valve stem	2	2	2	2
9	24 017 01-S	Valve, intake, standard	2	2	2	2
9	24 017 02-S	Valve, intake, 0.25	2	2	2	2
10	24 041 08	Gasket, cylinder head	2		2	
10	24 041 37-S	Gasket, cylinder head		2		2
11	24 016 01-S	Valve, exhaust, standard	2	2	2	2
11	24 016 02-S	Valve, exhaust, 0.25	2	2	2	2
12	24 402 03-S	Reed, breather	1	1	1	1
13	12 018 01	Retainer, breather reed	1	1	1	
13	66 018 04-S	Retainer, reed				1
14	M-545010-S	Screw, hex flange, M5 x 0.8 x 10	1	1	1	1
15	24 033 01-S	Kit, breather	1	1	1	1
16	24 041 51-S	Gasket, breather	1	1	1	1
17	24 096 86-S	Cover, breather	1	1	1	1
18	25 139 60-S	Plug, 1/8 in.	1	1	1	1
19	M-645020-S	Screw, hex flange, M6 x 1.0 x 20	1	1	1	1
20	M-645030-S	Screw, thread forming, M6 x 1.0 x 30	3	3	3	3
21	24 326 26-S	Hose, breather	1	1	1	1
22	25 237 14-S	Clamp, breather	1	1	1	1
23	12 445 05-S	Strap, lifting	2		2	2
23	24 445 01	Strap, lifting		2		
24	24 755 46-S	Kit, oil fill cap (includes 25, 26)	1	1	1	1
25	25 153 02	O-ring, oil fill cap	1	1	1	1
26	12 173 04	Cap, oil fill tube	1	1	1	1
27	24 755 74-S	Kit, valve cover, plain (includes 28, 31, 35, 42)	1	1	1	1
28	24 112 08	Spacer	4	4	4	4
30	24 755 75-S	Kit, valve cover, oil fill (includes 31, 32, 33, 35)	1	1	1	1
31	24 086 32	Screw, shoulder	4	4	4	4
32	24 096 21	Rocker cover, oil fill	1	1	1	1
33	24 112 08-S	Spacer	4	4	4	4
35	24 153 23-S	O-ring	1	1	1	1
36	24 050 01-S	Filter, breather	1	1	1	1
37	M-640034-S	Screw, hex flange, M6 x 1.0 x 34	4	4	4	4
38	24 755 66-S	Kit, valve train (includes 39, 40, 41)	1	1	1	1
39	24 599 01-S	Pivot, rocker arm	4	4	4	4
40	24 411 05-S	Rod, push	4	4	4	4
41	25 186 01-S	Arm, rocker	4	4	4	4
42	M-651030-S	Screw, valve cover	8	8	8	8
43	25 351 01-S	Lifter, valve	4	4	4	4
44	24 072 09-S	Stud (not shown)				8
45	24 100 10-S	Nut, hex flange (not shown)				8
46	24 468 16-S	Washer, flat (not shown)				8
47	24 605 01-S	Liner, exhaust port (not shown)				2

Group 5: Ignition/Electrical

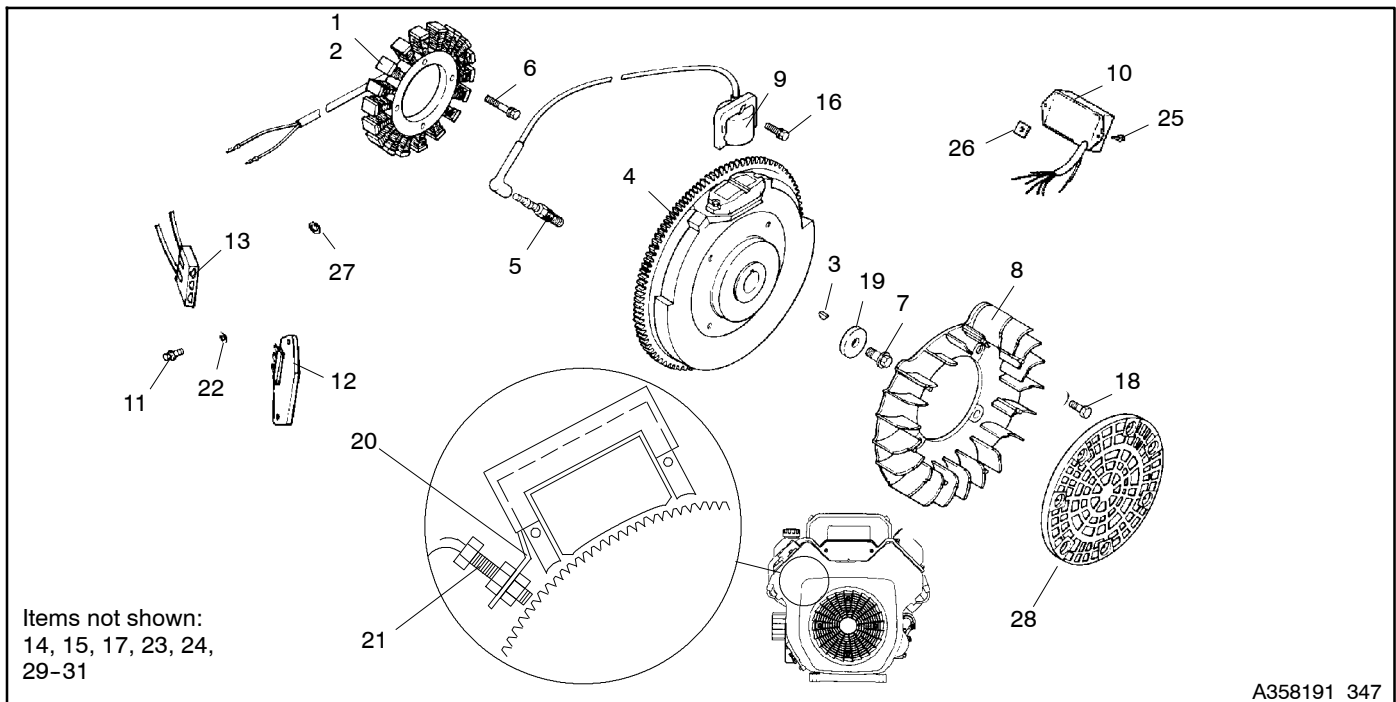

Item	Part Number	Description	Qty.				
			Variation No.				
			347	348	689	695	1058
1	54 755 09	Kit, 15-amp stator	1	1			
2	24 126 71	Bracket, stator wire	1	1			
3	X-42-15-S	Key	1	1	1	1	1
4	24 025 14-S	Flywheel	1				
4	24 025 05-S	Flywheel		1			
4	24 025 15-S	Flywheel			1		
4	66 025 01-S	Flywheel				1	1
5	12 132 02-S	Spark plug	2	2	2	2	2
5	25 132 14-S	Spark plug (RFI)					2
6	M-0548025	Screw, hex cap, M5 x 0.8 x 25	2	2			
7	12 086 14-S	Screw, hex flange, M10 x 1.5 x 46	1	1	1	1	1
8	24 157 07-S	Fan	1	1	1	1	1
9	24 584 45-S	Module, ignition	2			2	
9	25 584 05-S	Module, ignition					2
9	24 584 36-S	Module, ignition (module has 2 terminals)		2	2		
9	24 584 63-S	Module, ignition (module has 3 terminals)		2			
9	24 584 65-S	Module, ignition (3-4 wires)			2		
10	24 584 10-S	Module, speed advance		1			
10	24 584 34-S	Module, digital spark advanced (DSAM)			1		
11	24 086 18-S	Screw, Phillips head, 11-16 x 7/8	2	2	2	2	2
12	25 403 03	Rectifier-regulator	1	1			
13	236602	Connector, 3-contact	1	1			
14	25 518 28	Lead, black, 4 in. 18 gauge, insulated grip barrel eyelet terminals (not shown)	1	1			
15	24 176 43-S	Harness, wiring (not shown)	1			1	1
15	24 176 90-S	Harness, wiring (not shown)			1		
16	M-561025-S	Screw, hex socket head, M5 x 0.8 x 25	4	4	4	4	4
17	X-22-11	Washer, lock, 1/4 in. (not shown)	1	1	1		
18	25 086 47-S	Bolt, shoulder	4	4	4	4	4
19	12 468 03-S	Washer, plain, 3/8 in.	1	1	1	1	1
20	24 126 85-S	Bracket, sensor mounting	1	1	1	1	1
21	24 418 09-S	Sensor, magnetic	1	1	1	1	1
22	X-25-92-S	Washer, plain, 3/6 in.	2			2	2
23	24 518 18	Lead, white, 19 in. 18 gauge push-on tab terminals (not shown)		1			
24	24 518 17	Lead, red, 19 in. 18 gauge push-on tab terminals (not shown)		1			
25	24 086 41	Screw, hex cap, 10-24 x 3/8 in.		2			
26	24 100 02	Nut, plastic		2			
27	X-25-63-S	Washer, plain, 1/4 in.		1	1		
28	54 755 15-S	Screen	1	1			
29	25 096 04-S	Cover, regulator (not shown)			1	1	1
30	235173-S	Clip, cable (not shown)			1		
31	M-551016-S	Screw (not shown)			1		

Group 6: Blower Housing and Baffles

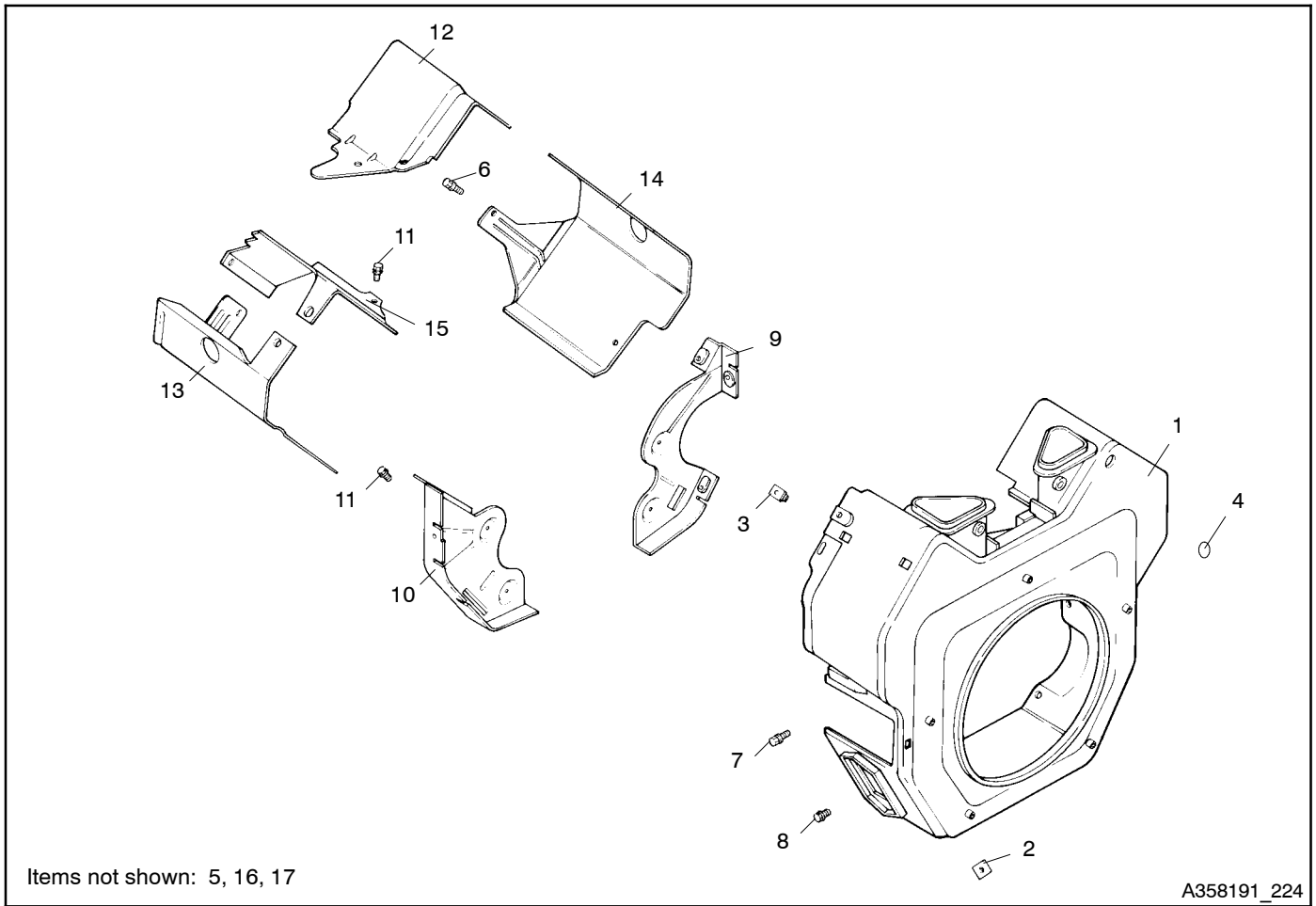

Items not shown: 5, 16, 17

A358191_224

Item	Part Number	Description	Qty.			
			Variation No.			
			224	225	350	352
1	24 027 30	Housing, blower assembly (includes 2-6)	1			
1	24 027 53-S	Housing, blower assembly (includes 2-6)		1		
1	24 027 195-S	Housing, blower assembly (includes 2-4)			1	1
2	24 100 01	Nut, plastic	3	2		
3	24 100 02	Nut, plastic	2	2		
4	25 139 16	Plug, button, 9/16 in.	1	1		
5	24 063 36	Baffle, blower housing (not shown)	1	1		
6	M-545010-S	Screw, hex flange, M5 x 0.8 x 10	2	2	2	2
7	M-545016-S	Screw, hex flange, M5 x 0.8 x 16	6	5	6	7
8	M-551016	Screw, hex flange, M5 x 0.8 x 16	1	1		
9	24 146 08	Plate, backing, #1 side	1	1		
9	24 146 20-S	Plate, backing, #1 side			1	1
10	24 146 11	Plate, backing, #2 side	1	1		
10	24 146 19-S	Plate, backing, #2 side			1	1
11	M-645016-S	Screw, hex flange, M6 x 1.0 x 16	8	8	8	8
12	24 063 24	Baffle, valley, #1 side	1	1		
12	24 063 59-S	Baffle, valley, #1 side			1	1
13	24 063 20	Baffle, cylinder barrel, #2 side	1	1		
13	24 063 39-S	Baffle, left barrel			1	1
14	24 063 08	Baffle, cylinder barrel, #1 side	1	1		
14	24 063 58-S	Baffle, right barrel			1	1
15	24 063 17-S	Baffle, valley, #2 side	1	1	1	1
16	24 113 12	Decal, HP (not shown)	1			
16	24 113 34	Decal, HP (not shown)		1		
17	M-545020-S	Screw (not shown)			2	2

Group 7: Starting System

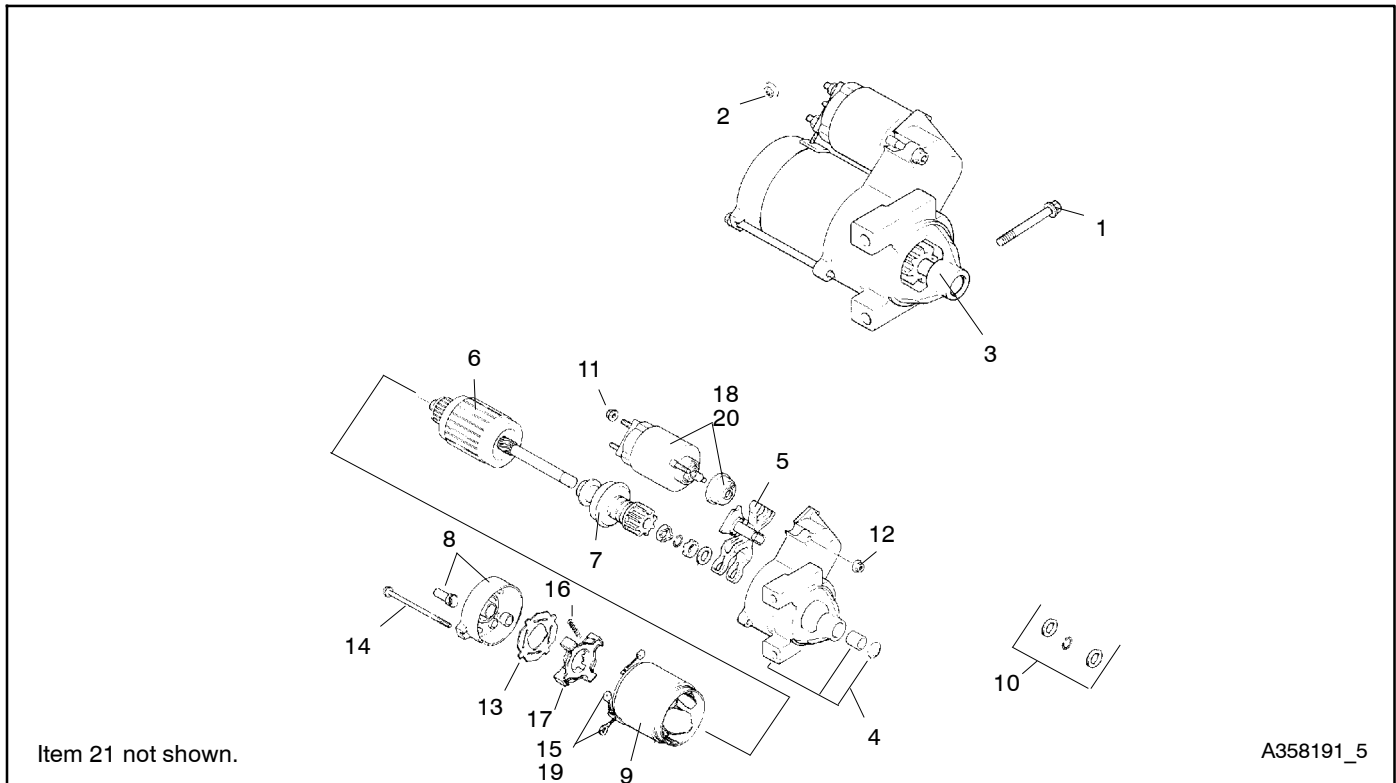

Item	Part Number	Description	Qty.
			Variation No. 13
1	M-839080-S	Screw, hex flange, M8 x 1.25 x 80	2
2	M-841080-S	Nut, hex flange, M8 x 1.25	1
3	24 098 01	Starter, Nipendenso label (not available, use 25 098 09-S) (includes 4-18)	1
3	25 098 09-S	Starter, solenoid shift Delco-Remy label (includes 19-21)	1
4	24 081 04	Drive, end cap	1
5	12 090 10	Lever, starter drive	1
6	12 170 04	Armature, starter	1
7	12 239 01	Drive, pinion	1
8	24 301 01	Commutator, end cap	1
9	12 471 01	Frame	1
10	24 755 84	Kit, starter repair	1
11	52 100 09	Nut, starter	1
12	52 100 10	Nut, starter	2
13	52 168 01	Insulator	1
14	52 211 05	Bolt, thru, M5 x 0.8 x 99	2
15	52 221 01	Kit, brush and spring (includes 16)	1
16	52 089 09	Spring, brush	4
17	52 323 03	Holder, brush	1
18	52 435 02	Solenoid	1
19	25 221 01-S	Kit, brush	1
20	25 435 05-S	Solenoid kit	1
21	25 755 33-S	Kit, starter pinion (not shown)	1

Group 8: Carburetor

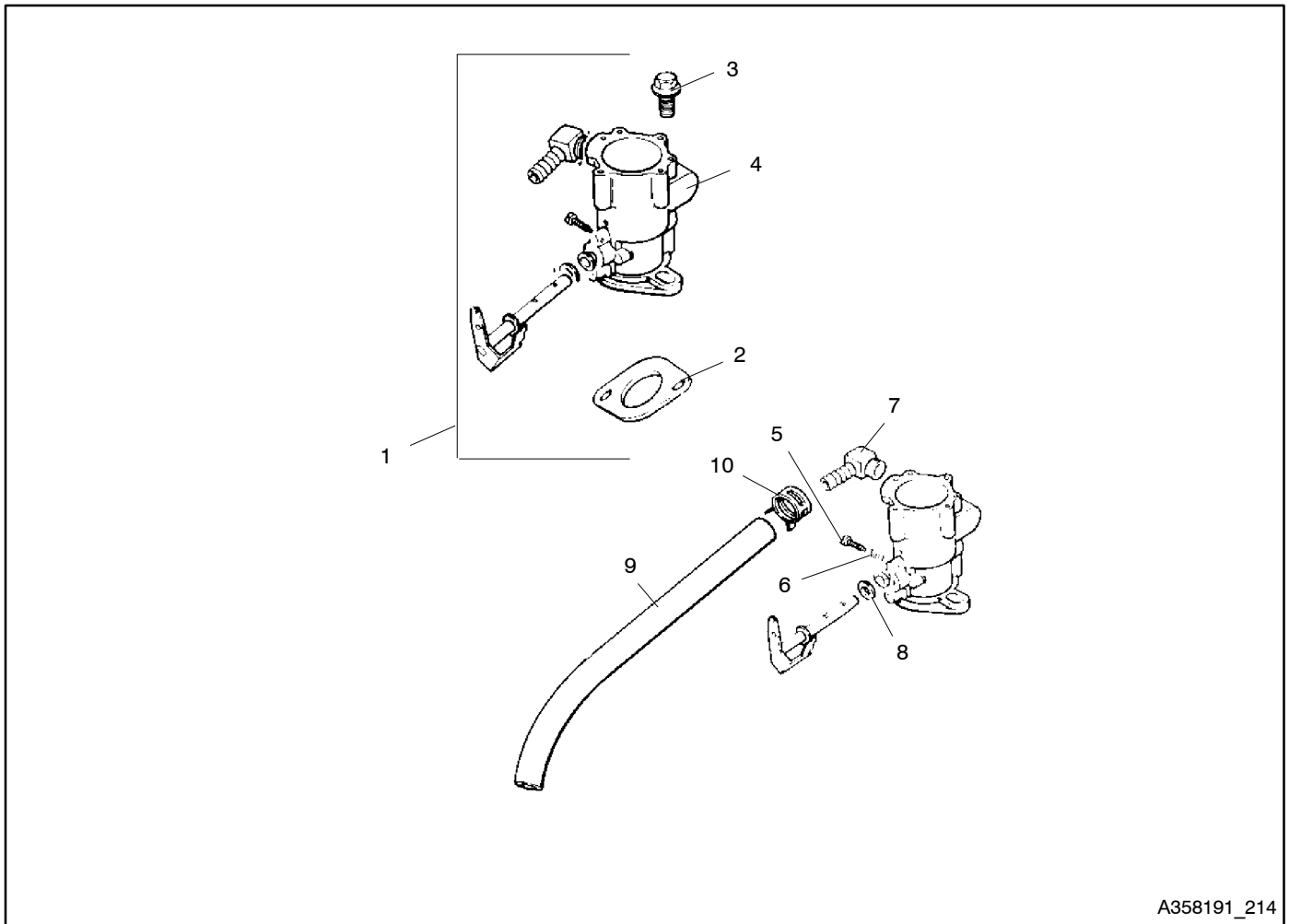

A358191_214

Item	Part Number	Description	Qty.			
			Variation No.			
			214	342	558	559
1	24 853 30-S	Kit, carburetor w/gasket (includes 2, 3)	1			1
1	24 853 49-S	Kit, carburetor w/gasket (includes 2, 3)		1	1	1
2	24 041 26-S	Gasket, carburetor	1	1	1	1
3	M-851030-S	Screw, hex flange, M6 x 1.25 x 30	2	2	2	2
4	24 053 30	Carburetor assembly (not available separately)	1			1
4	24 053 49	Carburetor assembly (not available separately)		1	1	
5	232556-S	Screw, idle adjusting	1	1	1	1
6	232555-S	Spring, adjusting screw	1	1	1	1
7	24 294 05-S	Fitting, elbow	1	1	1	1
8	X-25-8-S	Washer, plain, 1/4 in.	1	1	1	1
9	24 353 35	Line, fuel	1			
9	24 353 39	Line, fuel		1		
9	24 353 40-S	Line, fuel, 29 in.			1	1
10	25 237 09	Clamp, hose, 3/4 in.	1	1		
10	25 237 12-S	Clamp, hose			1	1

Group 9: Engine Controls

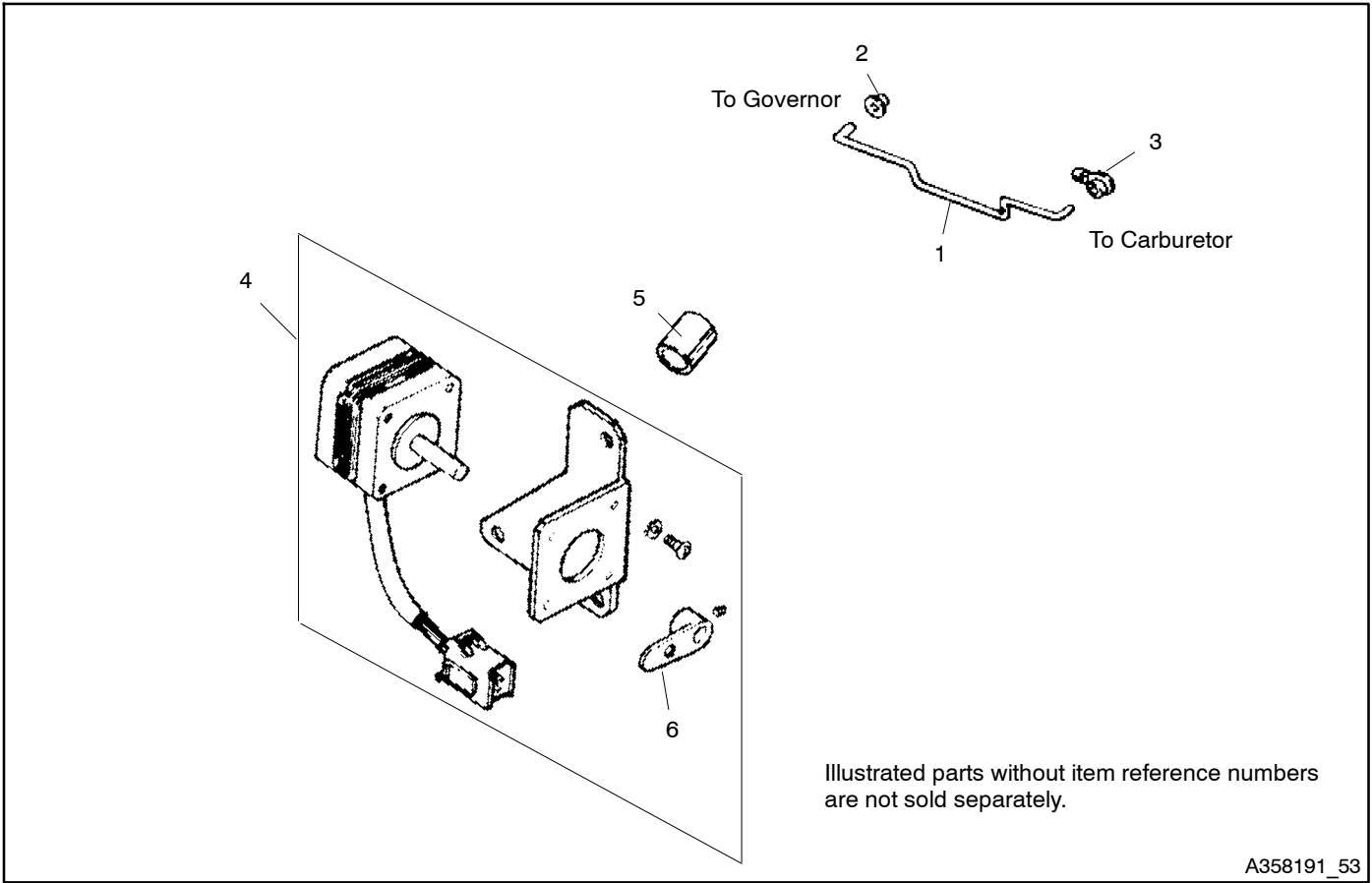

A358191_53

Item	Part Number	Description	Qty.
			Variation No. 98
1	24 079 09-S	Linkage, throttle	1
2	25 158 08-S	Bushing, linkage	1
3	25 158 11-S	Bushing, throttle linkage	1
4	24 310 03-S	Governor (actuator/stepper motor)	1
5	25 112 09-S	Spacer	3
6	358359	Coupling, stepper motor	1

Group 10: Air Intake/Filtration

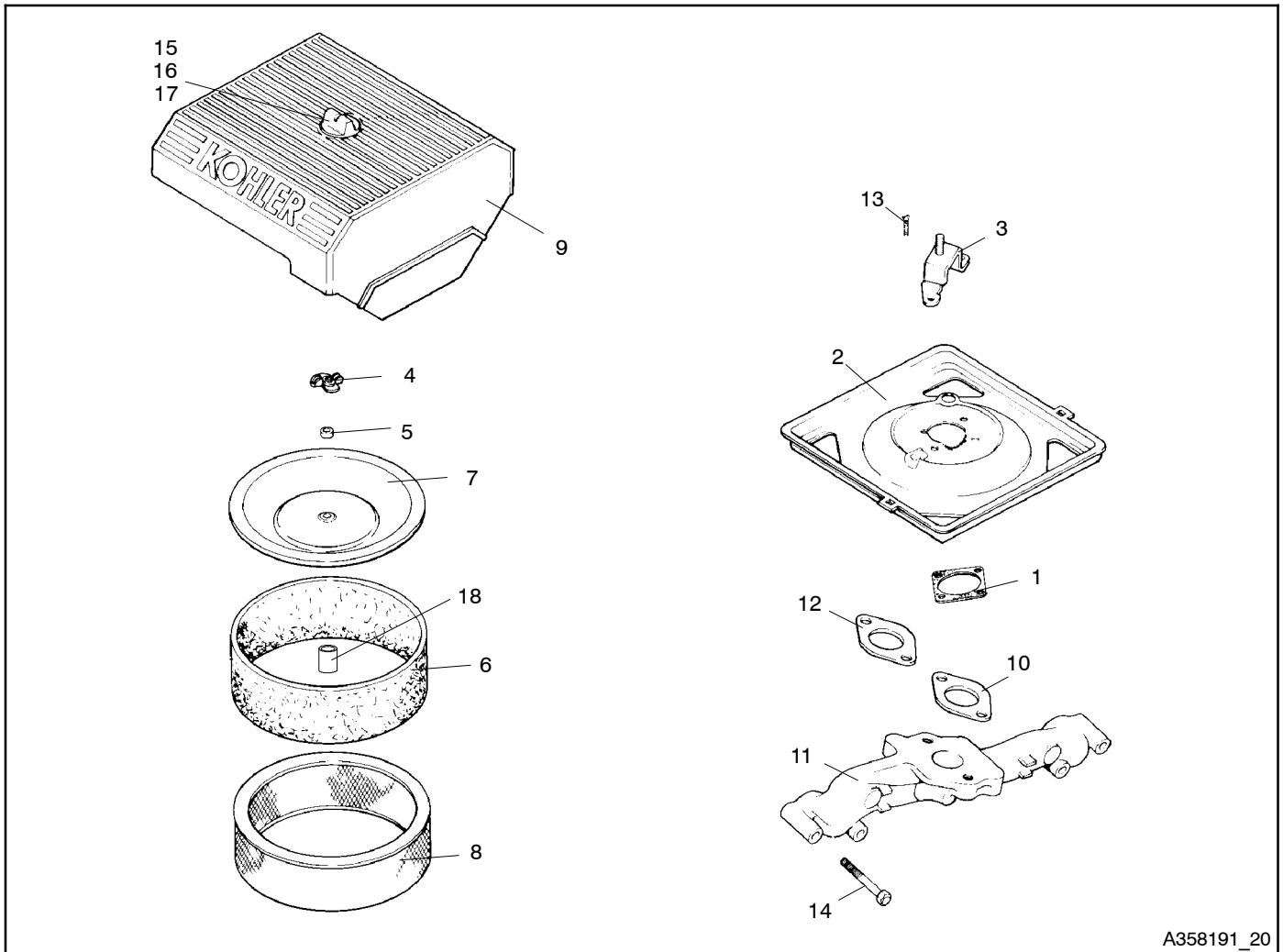

A358191_20

Item	Part Number	Description	Qty.	
			20	47
1	277093-S	Gasket, air cleaner base	2	2
2	24 094 12-S	Base, air cleaner	1	
2	24 094 29-S	Base, air cleaner		1
3	24 126 49-S	Bracket, air cleaner	1	
3	24 126 74-S	Bracket, air cleaner		1
4	12 100 01-S	Nut, wing	1	1
5	24 032 03-S	Seal, air intake	1	
6	24 083 02-S	Element, precleaner	1	
6	24 083 05-S	Element, precleaner		1
7	24 096 01-S	Cover, inner air cleaner	1	1
8	24 083 08-S	Element, air filter	1	
8	24 083 09-S	Element, air filter		1
9	24 096 67-S	Cover, air cleaner	1	1
10	24 041 01-S	Gasket, intake manifold	2	2
11	24 164 18-S	Manifold, intake	1	1
12	24 112 21-S	Spacer	1	1
13	25 086 48-S	Screw, composite, 10-32 x 3/4 in.	4	4
14	25 086 84-S	Screw, hex flange, M6 x 1.0 x 55	4	4
15	54 755 01-S	Kit, knob w/seal (includes 16, 17)	1	1
16	24 153 20-S	O-ring	1	1
17	25 341 03-S	Knob, cover	1	1
18	230046-S	Seal, breather		1

Group 11: Exhaust

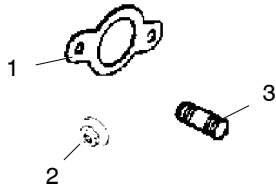

A358191_6

Item	Part Number	Description	Qty.
			Variation No.
			90
1	24 041 49-S	Gasket, exhaust manifold	2
2	M-841080-S	Nut, hex flange, M8 x 1.25	4
3	25 072 04-S	Stud, M8 x 1.25 x 33	4

Group 12: Gasket Set

Item	Part Number	Description	Qty.
			Variation No.
			1
1	24 755 03	Gasket set (includes all of the following)	1
	230046	Seal, breather	1
	12 032 01	Seal, valve stem	1
	12 153 01	O-ring	1
	12 153 02	O-ring	1
	12 153 03	O-ring	1
	24 032 01	Seal, front	1
	24 032 03	Seal, inner	1
	24 032 04	Seal	1
	24 032 05	Seal, valve stem	2
	24 041 01	Gasket, intake manifold	2
	24 041 02	Gasket, exhaust	2
	24 041 06	Gasket, air cleaner	1
	24 041 08	Gasket, cylinder head	2
	24 041 12	Gasket, oil filter	1
	24 041 13	Gasket, fuel	1
	24 041 14	Gasket, air cleaner	1
	24 041 15	Gasket, carburetor	1
	24 041 16	Gasket, cylinder head	2
	24 041 23	Gasket, breather	1
	24 153 08	O-ring	1
	52 032 08	Seal, oil	1

Group 103: Fuel System

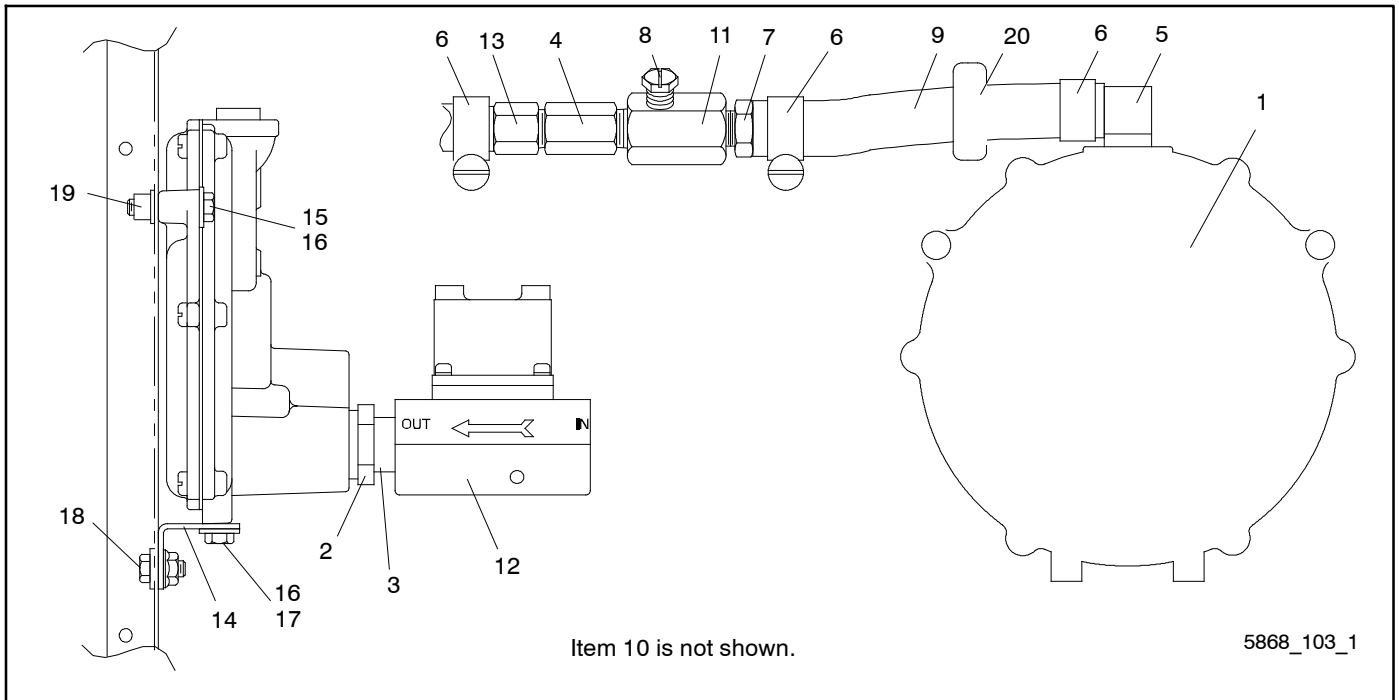

Item	Part Number	Description	Qty.		
			Variation No.		
			3	7	8
1	A-227531	Regulator assembly, gas	1	1	1
2	X-202-41	Bushing, reducer, 3/4 x 1/2 in.	1	1	1
3	X-209-2	Nipple, pipe, 1/2 NPT x 1.19 in.	1	1	1
4	X-216-29	Coupling, pipe, 1/4 in. brass	1	1	1
5	X-391-13	Connector, 90° hose, 3/8 NPTF x 1/2 in.	1	1	1
6	X-426-18	Clamp, hose, 0.38 x 0.88 in.	2	3	3
7	X-582-4	Connector, hose, 3/8 NPT x 1/2 in.	1	1	1
8	X-6219-8	Screw, set, 3/8-24 x 0.5 in. (LP gas, CARB cert.)	1	1	1
8	X-6219-9	Screw, set, 3/8-24 x 0.375 in. (natural gas, CARB cert.)	1	1	1
9	X-6242-9	Line, flexible fuel, 1/2 x 8.0 in.	1	1	1
10	X-75-51	Plug, pipe, 1/4 NPT (not shown)	1	1	1
11	226550	Block, fuel adjustment	1	1	1
12	227648	Valve, gas solenoid	1	1	1
13	344508	Connector, hose, 1/4 NPT x 1/2 in.	1	1	1
14	358147	Bracket, fuel mounting	1	1	1
15	X-465-8	Screw, 1/4-20 x 1.25	2	2	2
16	#	Washer, 1/4	4	4	4
17	X-465-2	Screw, 1/4-20 x 0.625	2	2	2
18	#	1/4-20	2	2	2
19	320828	Insert, threaded	2	2	2
20	243488	Grommet	1	1	1

Common hardware; procure locally.

Group 103: Fuel System, continued

View of Dual Fuel System

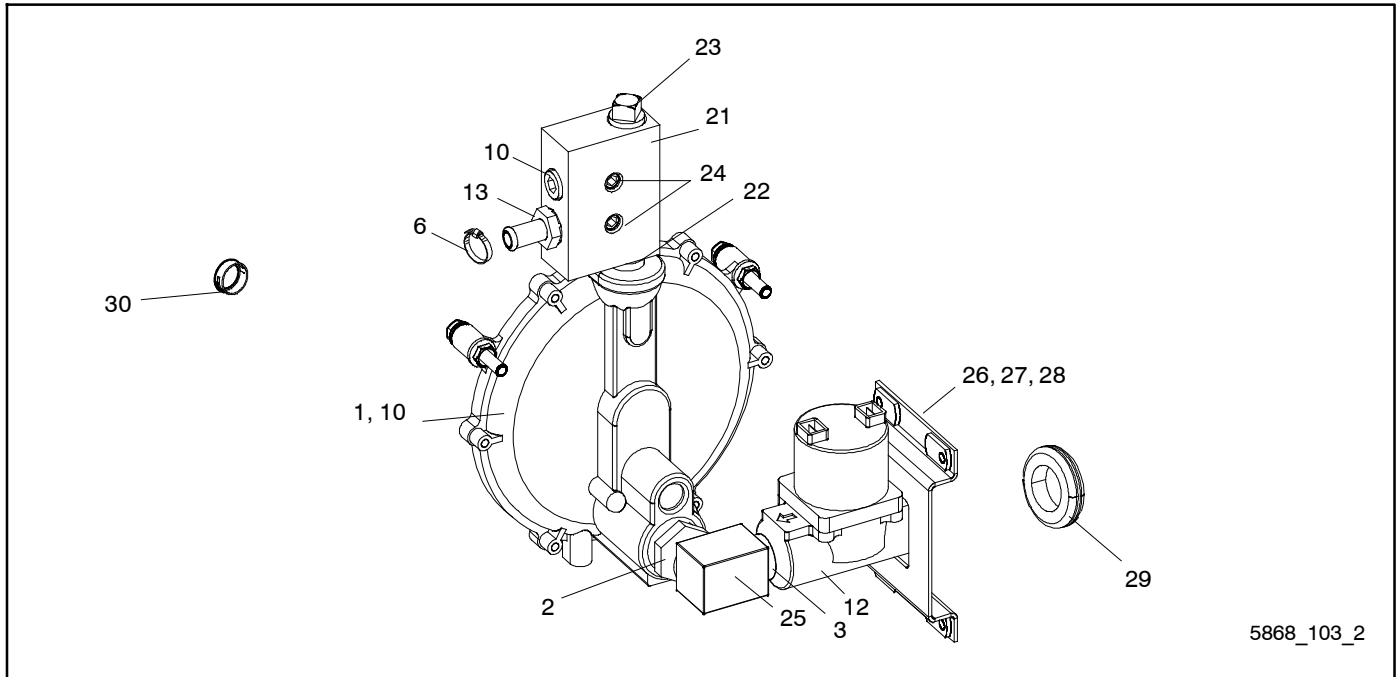

5868_103_2

Item	Part Number	Description	Qty.				
			GR3	29-3	53-3	53-15	53-17
1	A-227531	Regulator assembly, gas	1	1	1	1	1
2	X-202-41	Bushing, reducer, 3/4 x 1/2 in.	1	1	1	1	1
3	X-209-2	Nipple, pipe, 1/2 NPT x 1.19 in.	1	1	1	2	1
6	X-426-18	Clamp, hose, 0.38 x 0.88 in.	1	1	1		
6	X-426-3	Clamp, hose, 0.56/1.06 in.				1	1
10	X-75-51	Plug, pipe, 1/4 NPT	2	2	2	2	2
12	227648	Valve, gas solenoid	1	1	1		
12	GM39554	Valve, gas				2	1
13	344508	Connector, hose, 1/4 NPT x 1/2 in.	1	1	1	1	1
21	GM16807	Valve, fuel metering	1	1	1	1	1
22	X-204-9	Pipe, 3/8 in. NPT x 1.00 in.	1	1	1	1	1
23	X-75-10	Plug, pipe, 3/8 in. NPT	1	1	1	1	1
24	X-6219-9	Screw, set, 3/8-24 x 0.375 in., dual fuel	2	2	2	2	2
25	X-211-3	Elbow, street, 90° x 1/2 in. NPT)			1	1	1
26	GM31888	Plate, gas solenoid retainer			1	1	1
27	X-50-15	Screw, pan head, 10-24 x1/2			4	4	4
28	X-25-36	Washer, plain, 0.219 ID x 0.5 in. OD			4	4	4
29	X-284-3	Grommet, round					1
30	X-634-27	Bushing					1

Group 103: Fuel System, continued

Fuel System

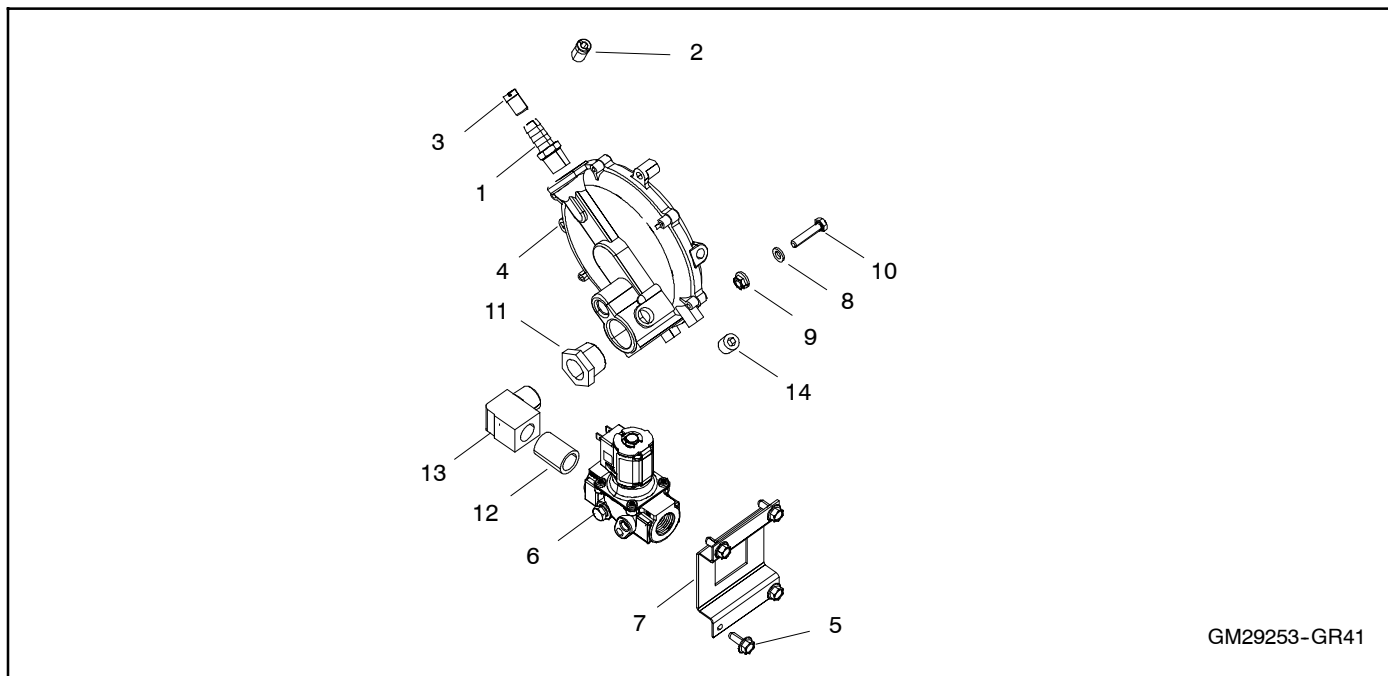

GM29253-GR41

Item	Part Number	Description	Qty.
			Variation No. 53-41
1	24 294 29	FITTING, STRAIGHT, LPG/NG	1
2	24 337 65	JET, LPG	1
3	24 337 66	JET, NG	1
4	A-227531	Regulator, gas	1
5	GM78761-1	Screw, Sheetmetal	4
6	GM85084	Valve, Gas Shut-off	1
7	GM94805	Plate, Gas Solenoid Retainer	1
8	M125A-06-80	Washer, Plain	2
9	M6923-06-80	Nut, Hex 6mm	2
10	M933-06030-60	Screw, Hex Cap	2
11	X-202-63	Bushing, Reducing (1/2 x 3/4"npt)	1
12	X-209-2	Pipe (1/2"npt x 1.19")	1
13	X-211-3	Elbow, Street(90 deg x 1/2"nptf)	1
14	X-75-51	Plug, pipe (1/4" nptf)	1

Group 105: Engine

8.5RMY & 11RMY

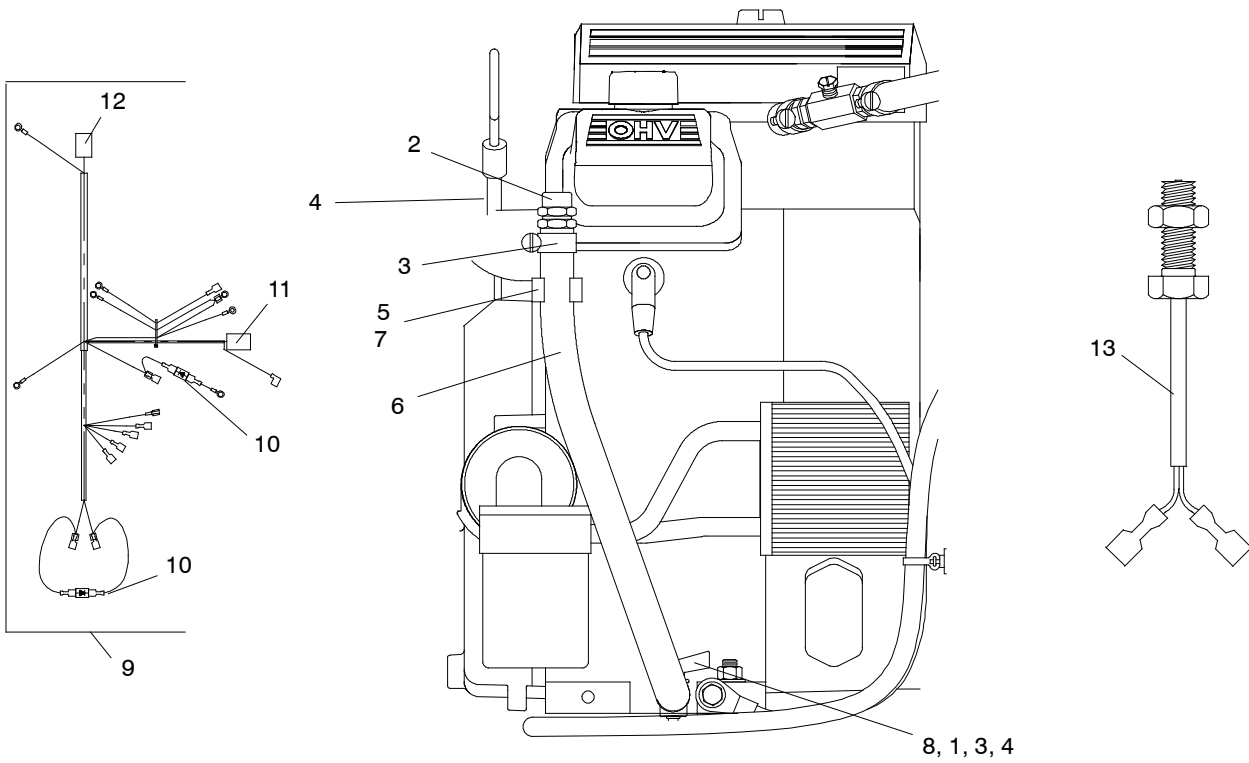

8.5RES & 12RES

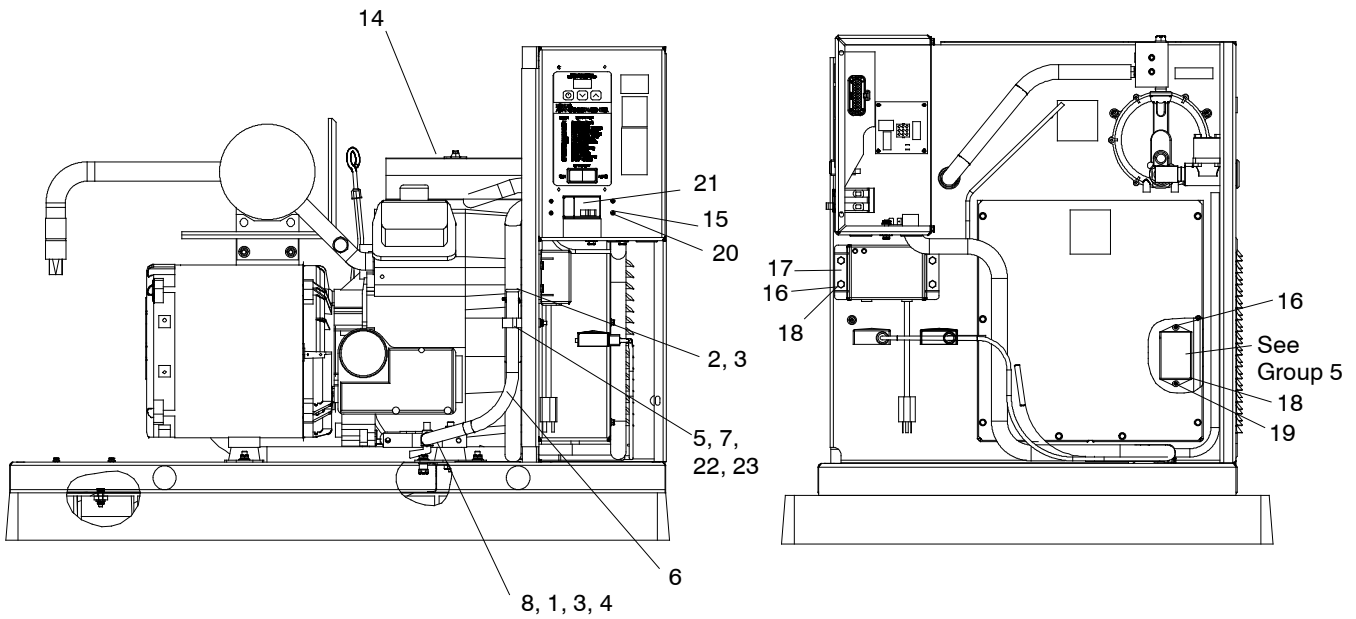

5868_105

Group 105: Engine

Item	Part Number	Description	Qty.																				
			Variation No.																				
			2	3	5	6	GR1	GR2	29-1	29-2	53-1	53-2	53-30										
1	X-204-9	Nipple, pipe, 3/8 x 1	1	1	1	1																	
2	X-268-9	Cap, pipe, 3/8 NPT	1	1	1	1																	
2	GM20548	Plug, hose 1/2					1	1	1	1													
2	GM20547	Plug, hose 3/8										1	1										
3	X-426-18	Clamp, hose, 0.38-0.88 in.	1	1	1	1	1	1	1	1													
3	X-426-9	Clamp, hose, 0.25/0.70 in.												1	1								
4	X-582-4	Connector, hose, 3/8 NPT x 1/2 in.	3	3	3	3	1	1	1	1													
4	X-216-23	Coupling, pipe, 3/8 in.												1	1								
5	M933-06010-60	Screw, hex head cap, M6-1 x 0.394 in.	1	1	1	1	1	1	1	1													
5	M933-06040-60	Screw, hex head cap												1	1								
6	X-422-19	Line, oil drain, 0.50 ID x 19 in.)	1	1	1	1	1	1	1	1													
6	X-651-3	Hose, rubber, 0.375 in. ID x 18 in.)												1	1								
7	345045	Clip, hose	1	1	1	1	1	1	1	1				1	1								
8	359653	Valve, oil drain	1	1	1	1	1	1	1	1				1	1								
9	358092	Harness, engine (includes 10, 11, 12)	1	1																			
9	GM10165	Harness, engine (includes 10, 11, 12)			1	1	1	1	1	1													
10	233959	Diode	2	2	2	2	2	2	2	2													
11	269190	Connector, 6-pin	1	1	1	1	1	1	1	1													
12	278775	Connector, 20-pin	1	1	1	1	1	1	1	1													
13	A-278782	Sensor assembly, magnetic	1		1																		
14	B-358191	Engine assembly, CH20 (EK64607)	1		1		1		1														
14	GM22470	Engine assembly, CH25 (EK68706)		1		1			1				1										
14	GM29359	Engine assembly, CH20 (EK64693)												1									
14	GM24792	Engine assembly, CH740 (EK CH740-0035)																		1			
14	GM66796	Engine assembly, CH640 (EK CH640-3036)																			1		
15	239332	Clip, speed																		4	4	4	
16	346258	Insert, threaded, #10-24																		4	6	4	
17	GM28341	Charger, battery																		1	1	1	
17	223316	Fuse, 10 amp (bat. charger)																		1	1	1	
18	X-50-15	Screw, slotted pan head machine																			2		
19	X-634-9	Bushing, 0.625 x 0.750 in NPT																			1		
19	X-301-24	Plug, button																			1		
20	X-67-143	Screw, cross recess, sheet metal																			4	4	4
21	GM24928	Breaker, circuit (40 A)																			1		1
21	358384	Breaker, circuit (50 A)																				1	
22	X-400-190	Spacer, 0.282 ID x 0.5 OD x 1 in.																			1	1	1
23	M6923-06-80	Nut, hex 6 mm																			1	1	1
24	X-426-18	Clamp, hose, 0.38-0.88 in.	1	1	1	1																	
24	X-309-11	Clamp, hose, 3/4						1	1	1	1	1	1	1	1	1	1	1	1	1	1	1	

See Group 112 Starter for additional engine group parts.

Group 107: Nameplate and Decals

Item	Part Number	Description	Qty.														
			Variation No.														
			4	12	13	14	GR4	GR10	29-4	29-5	53-5	53-10	53-11	53-12			
1	X-6348-2	Decal, Kohler Power Systems	1	1	1	1			1	1							
1	X-6348-8	Decal, Kohler Power Systems								1	1	1	1	1	1	1	1
2	224233	Decal, 1-800 number	1	1	1	1	1	1	1	1	1	1	1	1	1	1	1
2	GM35295	Decal, Sears 800 No.										1	1	1	1	1	1
3	227620	Decal, flag	1	1	1	1	1	1	1	1	1	1	1	1	1	1	1
4	239789	Decal, notice neutral bonded		1		1	1	1	1	1	1	1	1	1	1	1	1
5	249808	Decal, warning (rotating parts)	1	1	1	1	1	1	1	1	1	1	1	1	1	1	1
6	249809	Decal, warning (hot engine)	1	1	1	1	1	1	1	1	1	2	2	2	2	2	2
7	255798	Tag, instruction (warning when mounting)		1		1	1	1	1								
8	255882	Decal, transfer switch caution		1	1	1	1	1	1	1	1	1	1	1	1	1	1
9	257438	Decal, danger (voltage/rotor)	1	1	1	1	1	1	1	1	1	1	1	1	1	1	1
10	358313	Decal, electrical equipment		1				1	1	1	1						
11	GM14197-1	Decal, Kohler Generator (black)						1	1								
12	GM20577	Decal, fuel type							1	1	1	1	1	1	1	1	1
13	294520	Decal, danger high voltage					1	1	1	1	1	1	1	1	1	1	1
14	GM29924	Decal, notice fuel connection										1	1	1	1	1	1
15	GM15301	Decal, power breaker										1	1	1	1	1	1
16	GM15299	Decal, rainproof enclosure										1	1	1	1	1	1
17	GM39492	Decal, fuel holder															1

Item	Part Number	Description	Qty.			
			Module Number			
			GM60801-MA1	GM60801-MA2	GM60801-MA3	GM60801-MA4
1	X-6348-8	Decal, Kohler Power Systems	1	1	1	1
2	224233	Decal, 1-800 number			1	1
2	GM35295	Decal, Sears 800 No.		1		
3	227620	Decal, flag		1	1	1
4	239789	Decal, notice neutral bonded		1	1	1
5	249808	Decal, warning (rotating parts)		1	1	1
6	249809	Decal, warning (hot engine)		2	2	2
8	255882	Decal, transfer switch caution		1	1	1
9	257438	Decal, danger (voltage/rotor)		1	1	1
12	GM20577	Decal, fuel type		1	1	1
13	294520	Decal, danger high voltage		1	1	1
14	GM29924	Decal, notice fuel connection		1		1
15	GM15301	Decal, power breaker		1	1	1
16	GM15299	Decal, rainproof enclosure		1	1	1
17	GM39492	Decal, fuse panel			1	1

Item	Part Number	Description	Qty.
			Module Number
			GM60801-MA8
1	X-6348-8	Decal, Kohler Power Systems	1
2	224233	Decal, 1-800 number	1
4	239789	Decal, notice neutral bonded	1
5	249808	Decal, warning (rotating parts)	1
6	249809	Decal, warning (hot engine)	1
8	255882	Decal, transfer switch caution	1
9	257438	Decal, danger (voltage/rotor)	1
12	GM47407	Decal, fuel type	1
12	GM47408	Decal, fuel type (w/pipe size)	1
14	GM29924	Decal, notice fuel connection	1
16	GM15299	Decal, rainproof enclosure	1
18	GB31311173101	Decal, Emergency Stop	1

Notes

Group 109: Skid and Plant Mounting

8.5RMY & 11RMY

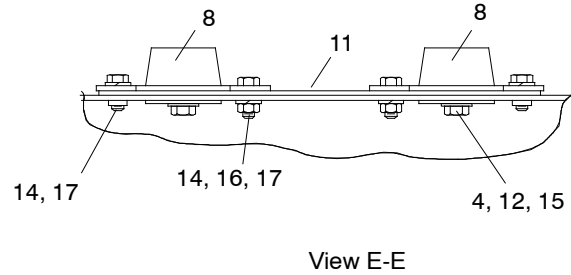
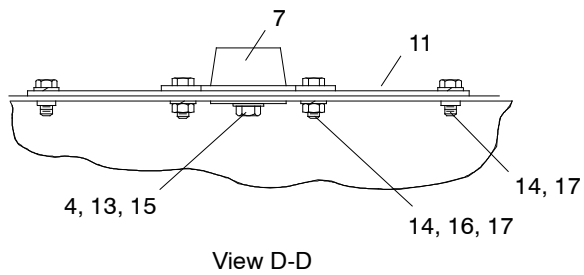
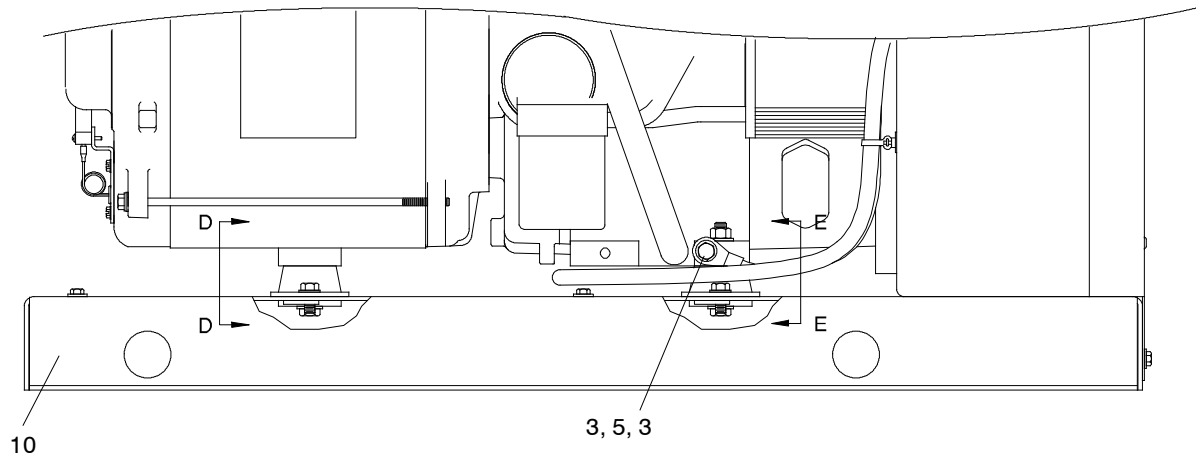

8.5RES & 12RES

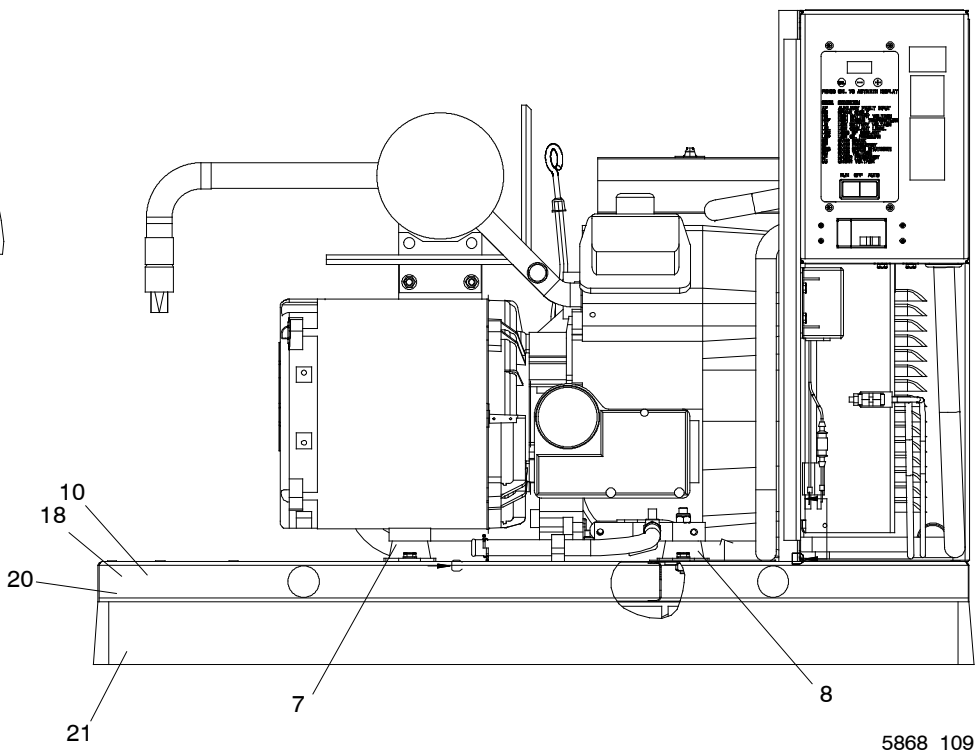
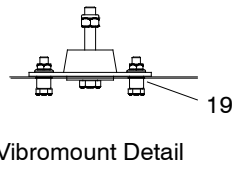
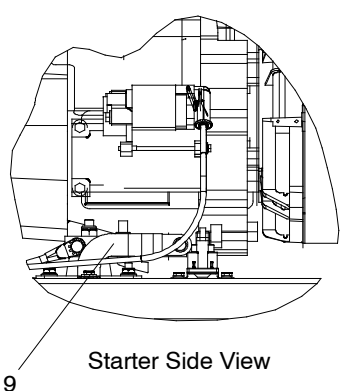

5868_109

Group 109: Skid and Plant Mounting

Item	Part Number	Description	Qty.				
			Variation No.				
			3	6	GR5	29-6	53-13
1	X-101-13	Nut, elastic stop, 3/8-16	2	2	2	2	
2	X-22-12	Washer, lock, 1/4 in., interior/exterior tooth	1	1	1	1	
3	X-22-16	Washer, lock, 5/16 in., interior/exterior tooth	1	1	1	1	
4	X-25-96	Washer, plain, 0.406 in. ID	3	3	3	3	
5	M933-08020-60	Screw, hex head cap, M8-1.25 x 0.787 in.	1	1	1	1	
6	X-67-115	Screw, self-tapping, 1/4-20	1	1	1	1	
7	229127	Vibromount	1	1	1	1	1
8	258659	Vibromount	2	2	2	2	2
9	290418	Strap, ground, 8.0 in.	1	1	1	1	
9	GM50449	Strap, ground, 16 in.					1
10	358137	Base, sub	1				
10	358387	Base, sub		1	1		
10	GM24791	Base, sub				1	
10	GM29256	Base, sub (used with GM29255)					1
11	358285	Plate, mounting	2	2	2	2	
12	X-6238-9	Bolt, hex cap, 3/8-16 x 3.0	2	2	2	2	
13	X-6238-10	Bolt, hex cap, 3/8-16 x 0.75	1	1	1	1	
14	X-125-3	Bolt, hex cap, 5/16-18 x 0.75	8	8	8	8	
15	#	Washer, plain, 3/8	3	3	3	3	
16	#	Nut, 5/16	4	4	4	4	
17	#	Washer, 5/16	8	8	8	8	
18	GM11040-2	Insert, threaded (6 mm) (used with base GM29255)					12
19	GM11040-4	Insert, threaded (used with base GM29255)					6
20	347176	Weight, balance (used with base GM29255)					6
21	GM29255	Base, plastic mounting					1
21	GM42141	Base, plastic mounting (effective 10/16/06)					1

Common hardware; procure locally.

Effective with units manufactured 10/16/06 (refer to nameplate for unit build date), metal base GM29256 and plastic base GM29255 were replaced by one piece plastic base GM42141.

Group 112: Starter

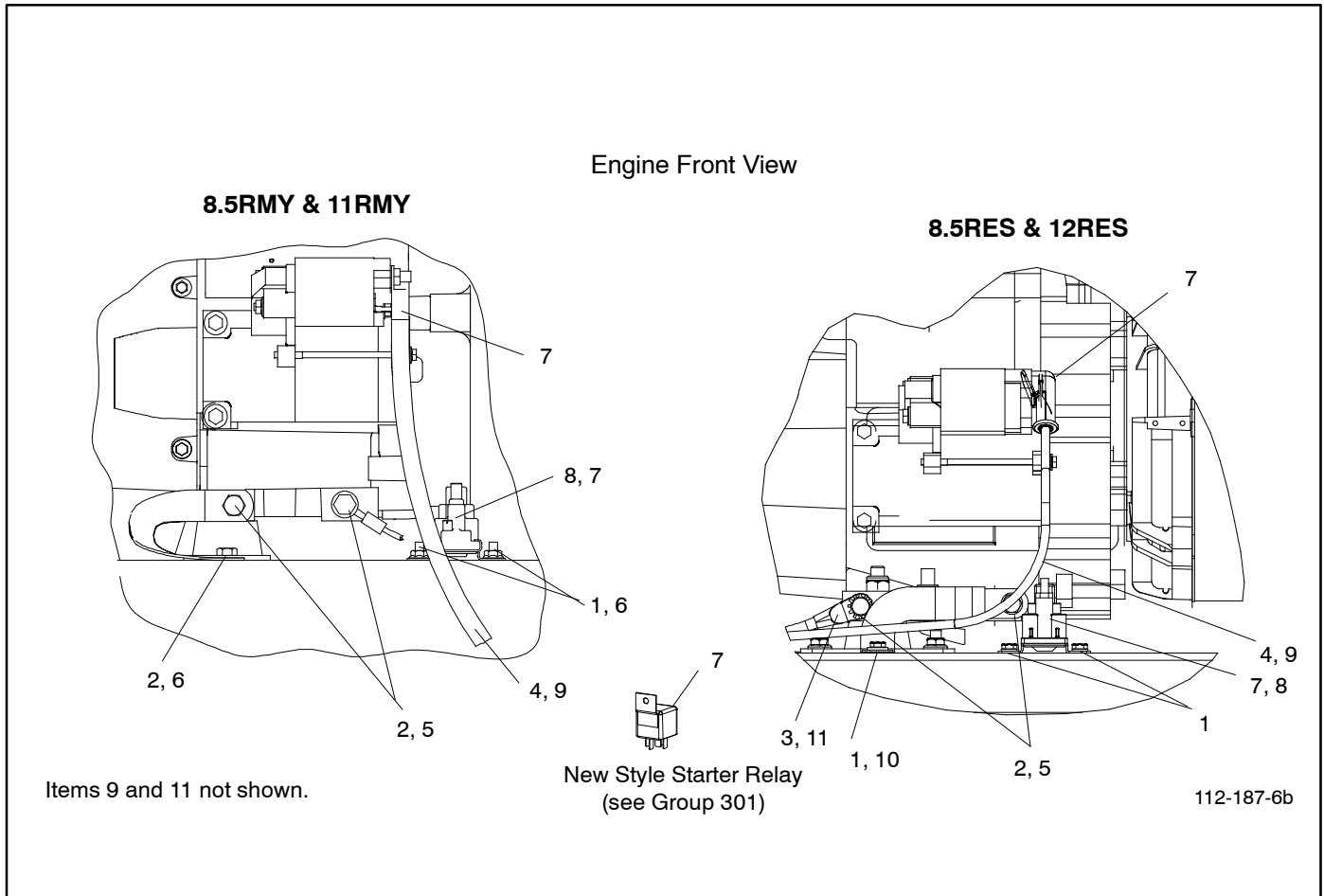

Group 112: Starter

Item	Part Number	Description	Qty.							
			Variation No.							
			4	6	GR1	GR2	29-1	29-2	53-1	53-2
1	X-22-12	Washer, lock 1/4 in. interior/exterior tooth	2	2	2	2	2	2	3	3
1	X-22-11	Washer, lock, 0.262 ID x 0.469 OD							2	2
2	X-22-16	Washer, lock 5/16 in. interior/exterior tooth	2	2	2	2	2	2	3	3
3	X-545-133	Cable, battery black (-), 22 in.	1	1	1	1	1	1		
3	GM33829	Kit, battery cable (prior to build date of May 1, 2004)							1	1
3	X-545-172	Cable, battery							1	1
4	X-545-134	Cable, battery red (+), 44 in.	1	1	1	1	1	1	1	1
5	M933-08020-60	Screw, hex head cap, M8-1.25 x 0.787 in.	2	2	2	2	2	2	2	2
6	X-67-115	Screw, self-tapping, 1/4-20	2	2	2	2	2	2		
7	238915	Boot	1	1	3	3	3	3	3	3
8	GM50772	Relay Service Kit for 345079	1	1	1	1	1	1	1	1
8	—	Relay (new style); see Group 301							1	1
9	GM20748	Boot, battery lug (not shown)			1	1	1	1	1	1
10	X-25-40	Washer, plain, 0.281 ID x 0.625 in. OD							1	1
11	GM33829	Kit, battery cable (prior to build date of May 1, 2004)							1	1
11	GM33146	Boot, battery lug							1	1

Group 116: Exhaust

8.5RMY & 11RMY

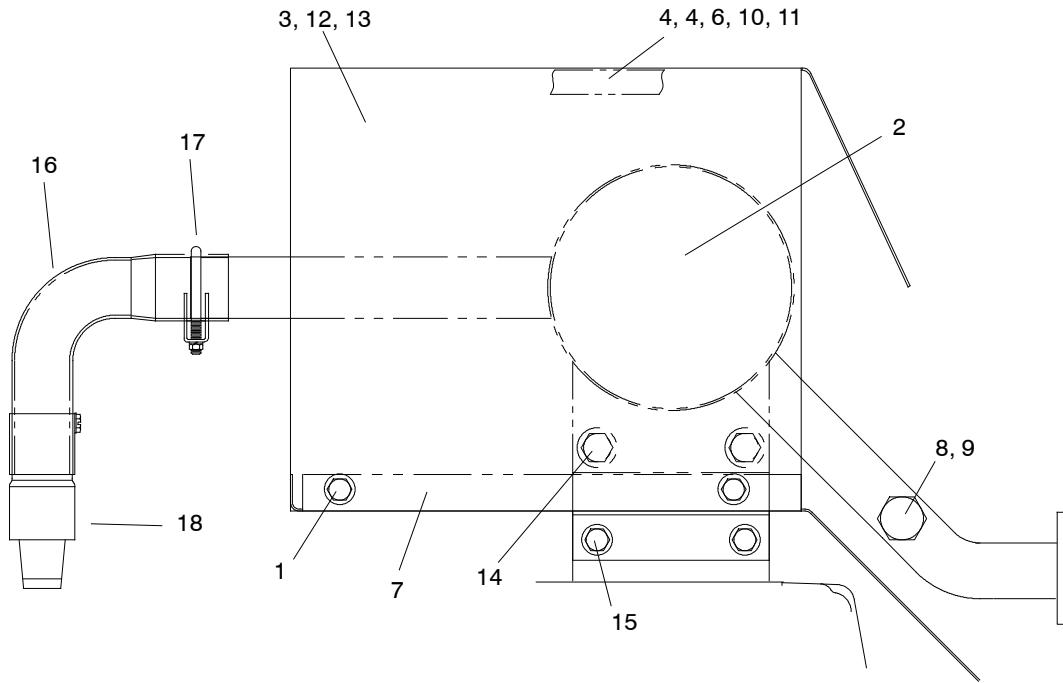

8.5RES & 12RES

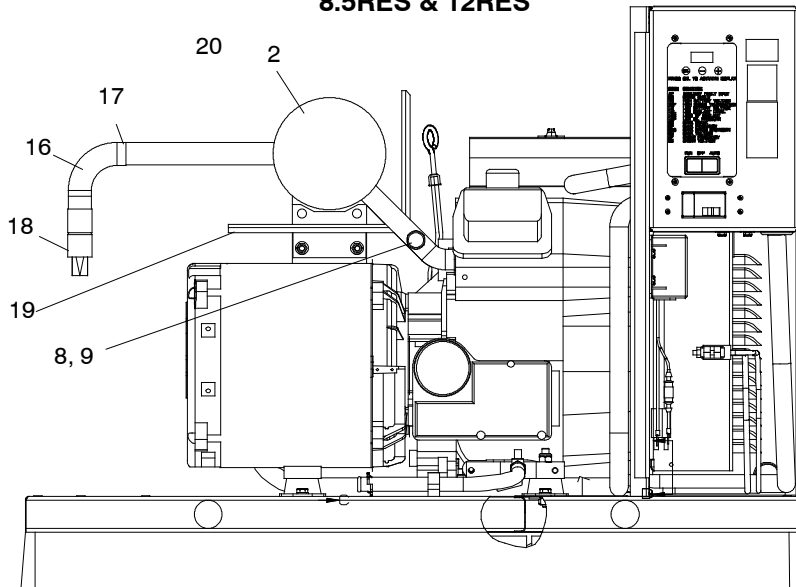

5868_116

Group 116: Exhaust

Item	Part Number	Description	Qty.				
			Variation No.				
			3	6	GR6	29-7	53-1
1	320828	Insert, threaded	4	4	4	4	
2	358073	Muffler	1				
2	GM10138	Silencer, exhaust		1	1	1	
2	GM29353	Silencer, exhaust					1
3	358106	Duct, exhaust top	1	1	1		
3	GM24800	Duct, exhaust top				1	
4	358123	Insulation, top	1	1	1		
4	GM24802	Insulation, top				1	
5	358124	Insulation, side	2	2	2		
5	GM24803	Insulation, side				1	
6	358135	Insulation	1	1	1		
6	GM24804	Insulation				1	
7	358214	Duct, exhaust bottom	1	1	1		
7	GM24801	Duct, exhaust bottom				1	
8	358224	Plug, oxygen test hole, M18 x 1.5	1	1	1	1	1
9	358306	Gasket	1	1	1	1	1
10	X-781-8	Rivet, 0.187 pop diameter	10	10	10	10	
11	X-25-45	Washer, plain, 0.208/0.198 ID	10	10	10	10	
12	X-465-2	Bolt, hex cap, 1/4-20 x 0.625	4	4	4	4	
13	#	Washer, plain, 1/4	4	4	4	4	
14	#	Hardware, 3/8-16	2	2	2	2	
15	#	Hardware, 1/4-20	2	2	2	2	
16	GM11720	Elbow, exhaust tube		1	1	1	
17	X-722-8	Clamp, muffler, 1.37 in.		1	1	1	
18	GM39500	Arrester, spark		1	1	1	1
19	GM29983	Shield, heat					1

Common hardware; procure locally.

Group 201: Generator and Mounting

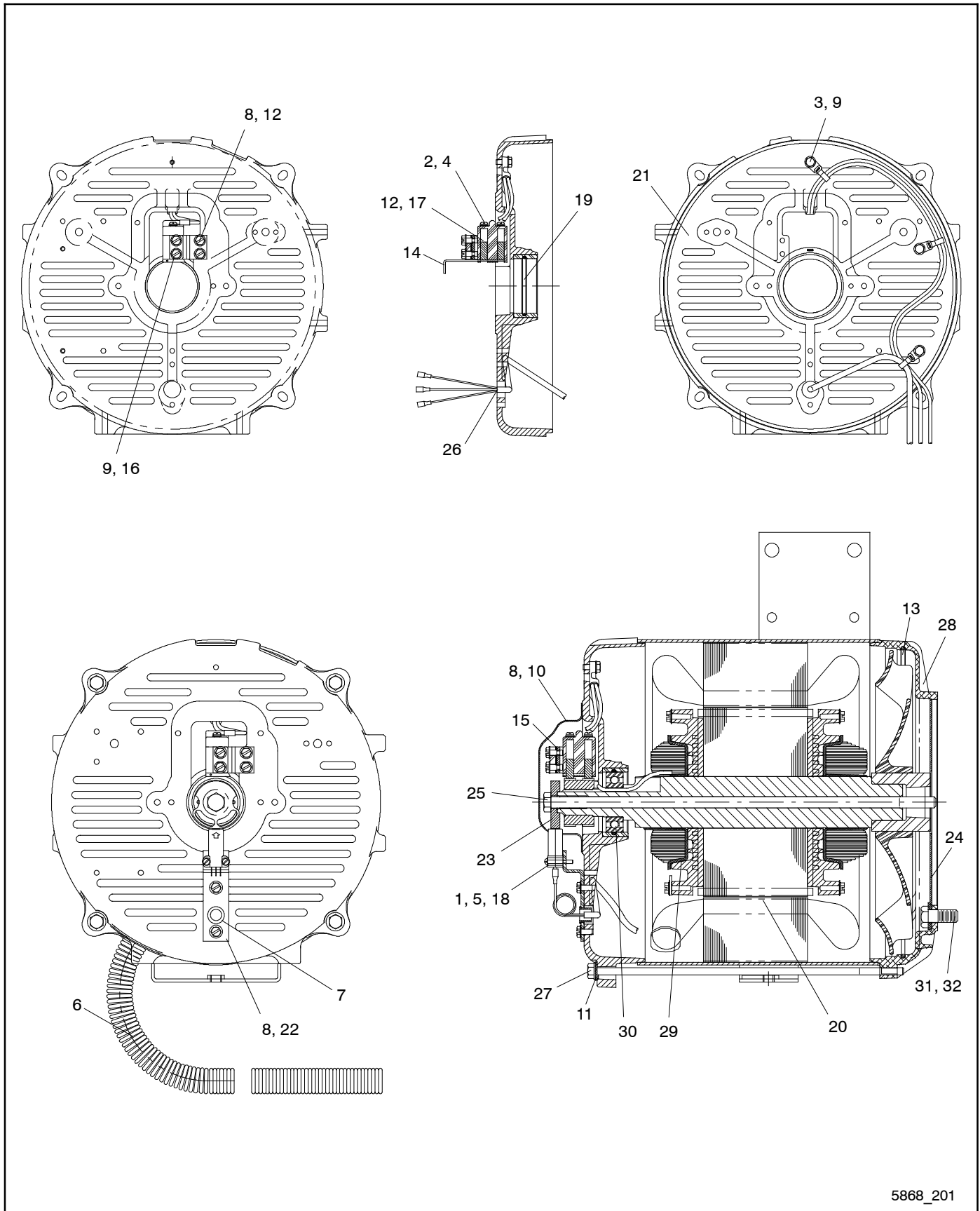

5868_201

Group 201: Generator and Mounting

Item	Part Number	Description	Qty.					
			Variation No.					
			5	10	GR7	29-8	53-7	53-32
1	X-22-24	Washer, lock #4, internal tooth	2	2	2	2		
2	X-22-6	Washer, lock #6, internal tooth	2	2	2	2	2	2
3	X-468-3	Tie, cable nylon	3	3	3	3	3	3
4	X-49-1	Screw, pan head machine, #6-32 x 0.312	2	2	2	2	2	2
5	X-49-35	Screw, pan head machine, #4-40 x 0.875	2	2	2	2		
6	X-6003-46	Conduit, convoluted	1	1	1	1		
6	X-6003-126	Conduit, convoluted					1	1
7	X-634-5	Bushing, nylon, 0.375 ID	1	1	1	1		
8	X-67-113	Screw, self-tapping, 10-32 x 0.375	8	8	8	8	4	4
9	X-97-13	Screw, hex head machine, 10-32 x 0.438	5	5	5	5	5	5
10	227473	Cover, brush holder	1	1	1	1		
10	278877	Cover, brush holder					1	1
11	229239	Washer, overbolt	4	4	4	4		
11	X-25-68	Washer, plain, .281 ID x .625 in. OD					4	4
12	229335	Bracket, brush holder	1	1	1	1	1	1
12	238150	Spring	2	2	2	2	2	2
13	238214	Guard, generator fan	1	1	1	1	1	1
14	238247	Retainer, wire	1	1	1	1	1	1
15	238248	Shim, brush holder	2	2	2	2	3	3
16	239247	Holder, brush	1	1	1	1	1	1
17	239282	Brush	2	2	2	2	2	2
18	241927	Kit, sensor	1	1	1	1		
19	256466	O-ring	1	1	1	1	1	1
20	358014	Stator assembly	1					
20	GM10565	Stator assembly		1	1	1		
20	GC29774	Stator assembly					1	
20	GC65807	Stator assembly						1
21	358054	Bracket, end	1	1	1	1		
21	GM38291	Bracket, end					1	1
22	358056	Bracket, sensor mounting	1	1	1	1		
23	358066	Actuator, magnetic	1	1	1	1		
23	X-801-3	Washer, hardened					1	1
24	358067	Guard, alternator adapter	1	1	1	1	1	1
25	358072	Bolt, thru	1	1	1	1	1	1
26	358090	Harness, sensor	1	1	1	1		
27	358102	Overbolt	4	4	4	4	4	4
28	359654	Adapter, generator	1	1	1	1	1	1
29	GM46819	Rotor assembly (includes 30, 30.1)	1	1	1	1	1	1
30	X-758-1	Bearing, ball	1	1	1	1	1	1
30.1	GM53091	Ring, collector	4	4	4	4	4	4
31	X-6024-2	Bolt, hex cap, 7/16-14 x 1.0	4	4	4	4	4	4
32	X-25-34	Washer, 7/16	4	4	4	4	4	4

Group 301: Controller and Mounting

8.5RMY & 11RMY

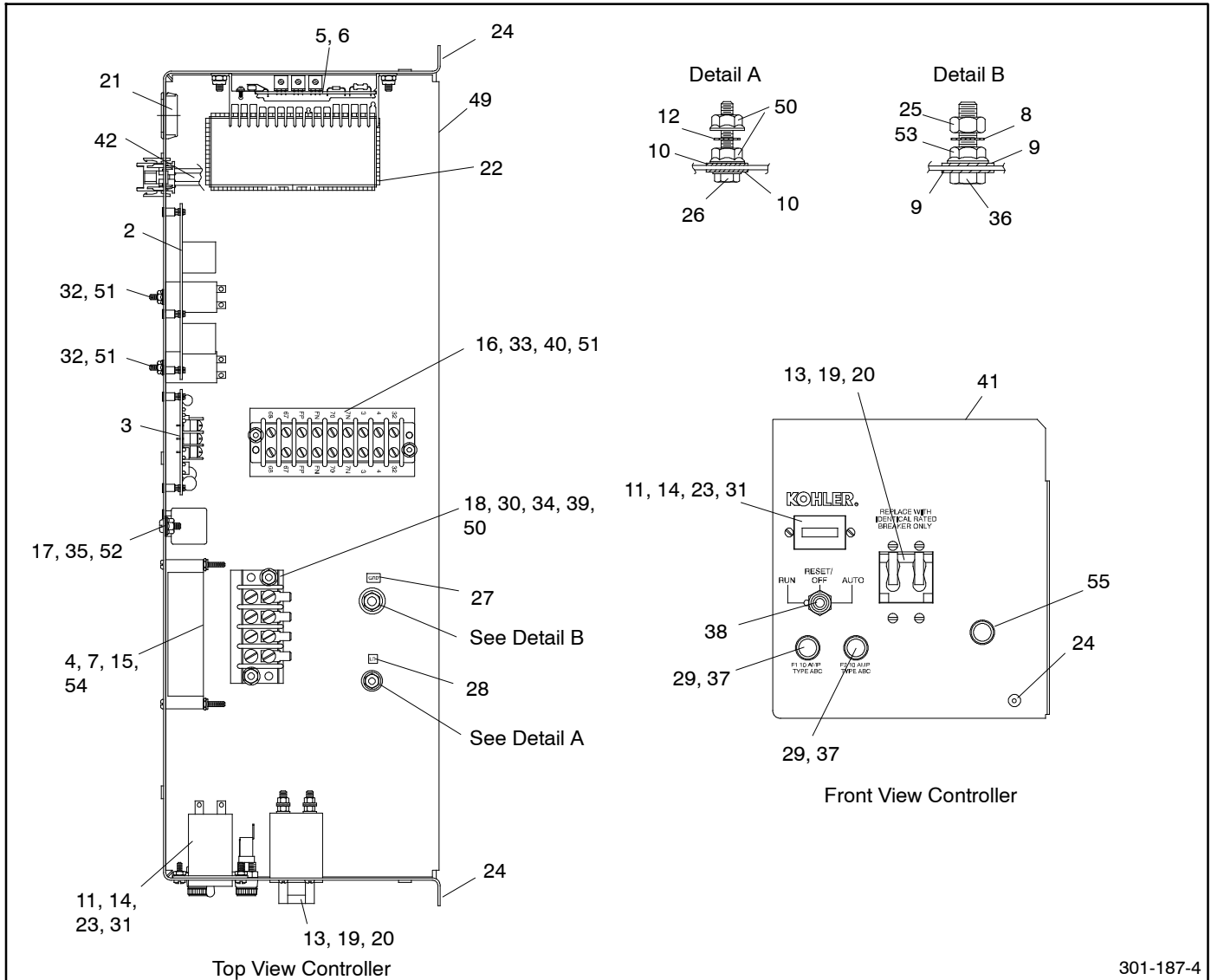

301-187-4

Group 301: Controller and Mounting

Item	Part Number	Description	Qty.						
			Variation No.						
			4	5	9	10	GR8	29-9	29-11
1	A-358076	Controller assembly (includes items 2-54)	1						
1	A-358099	Controller assembly (includes items 2-54)		1					
1	B-358076	Controller assembly (includes items 2-54)			1				
1	GM10615	Controller assembly (includes items 2, 4-12, 14-18, 21-55)				1	1	1	1
2	B-358095	PCB assembly, relay controller	1	1	1				
2	GM10064	PCB assembly, relay controller				1	1	1	1
3	C-284507	PCB assembly, cyclic cranking	1	1	1				
4	D-278670	Governor assembly, electronic	1	1	1	1	1	1	1
5	F-228605	Kit, voltage regulator	1	1	1	1	1	1	1
6	X-101-12	Nut, elastic stop, 10-32	4	4	4	4	4	4	4
7	X-101-22	Nut, elastic stop, 6-32	4	4	4	4	4	4	4
8	X-22-11	Washer, lock, 1/4, internal tooth	1	1	1	1	1	1	1
9	X-22-12	Washer, lock, 1/4, interior/exterior tooth	2	2	2	2	2	2	2
10	X-22-13	Washer, lock #10, interior/exterior tooth	2	2	2	2	2	2	2
11	X-22-6	Washer, lock #6, interior/exterior tooth	2	2	2	2	2	2	2
12	X-22-9	Washer, lock #10, internal tooth	1	1	1	1	1	1	1
13	X-67-143	Screw, cross recess, sheet metal	4	4	4	4	4	4	4
13	239332	Clip, speed				4	4	4	4
14	X-49-39	Screw, PHM 6-32 x 0.50	2	2	2	2	2	2	2
15	X-49-46	Screw, PHM 6-32 x 1.75	4	4	4	4	4	4	4
16	X-49-6	Screw, RHM 6-32 x 0.75	2	2	2	2	2	2	2
17	X-50-1	Screw, RHM 10-32 x 0.50	1	1	1				
18	X-50-70	Screw, PHM 10-24 x 1.0	2	2	2				
19	X-506-43	Breaker, circuit, 42 amp	1						
19	X-506-38	Breaker, circuit, 50 amp		1					
20	358384	Breaker, circuit			1	1	1	1	
20	GM24928	Breaker, circuit							1
21	X-634-14	Bushing, nylon	1	1	1	1	1	1	1
22	X-6047-35	Channel, U	1	1	1	1	1	1	1
23	X-71-2	Nut, hex, 8-32	2	2	2	2	2	2	2
24	X-781-14	Rivet, pop, 0.187, aluminum/aluminum	5	5	5	5	5	5	5
25	X-81-8	Nut, hex, 1/4-20, green	1	1	1	1	1	1	1
26	X-97-16	Screw, hex head machine, 10-24 x 1.0	1	1	1	1	1	1	1
27	201620-152	Tab, identification, GRD	1	1	1	1	1	1	1
28	201620-94	Tab, identification, LO	1	1	1	1	1	1	1
29	223316	Fuse, 10A	2	2	2	2	2	2	2
30	238582	Terminal	4	4	4				
31	238736	Meter, hour	1	1	1	1	1	1	1
32	241736	Relay	2	2	2				
33	254821	Marker, strip TB1	1	1	1	1	1	1	1
34	254822	Marker, strip TB2	1	1	1				
35	259391	Relay, 20A	1	1	1				
36	267491	Screw, hex cap, 1/4-20 x 1.0	1	1	1	1	1	1	1
37	267996	Holder, fuse	2	2	2	2	2	2	2
38	287812	Switch, toggle	1	1	1	1	1	1	1
39	292940	Strip, terminal	1	1	1				
40	295313	Block, terminal	1	1	1	1	1	1	1
41	358086	Box, silkscreen	1	1					
41	GM10399	Box, silkscreen			1				
41	GM10616	Box, silkscreen				1	1	1	1
42	GM10618	Harness, controller (includes 43-48)				1	1	1	1
42	358091	Harness, controller (includes 43-48)	1	1					
42	GM11693	Harness, controller (includes 43-48)			1				
43	239408	Connector, 4 pin, P2	1	1	1	1	1	1	1
44	239411	Connector, 4 pin, J8	1	1	1	1	1	1	1
45	241605	Connector, 12 pin, P7	1	1	1	1	1	1	1
46	269190	Connector, 6 pin, P10	1	1	1	1	1	1	1
47	278775	Connector, 20 pin, P1				1	1	1	1
47	269366	Connector, 15 pin, P1	1	1	1				
48	278774	Connector, 20 pin, J4	1	1	1	1	1	1	1
49	358145	Panel, controller bottom	1	1	1	1	1	1	1
50	#	Nut, 10-24	4	4	4	2	2	2	2
51	#	Nut, 6-32	2	2	2	2	2	2	2
52	#	Nut, 10-32	2	2	2				
53	#	Nut, 1/4-20	1	1	1	1	1	1	1
54	X-25-48	Washer, plain, .188 ID x .438 OD	4	4	4	4	4	4	4
55	269373	Lamp, 14 V, .33 W				1	1	1	1

Common hardware; procure locally.

Group 301: Controller and Mounting, continued

8.5RES & 12RES ADC-2100 Controller

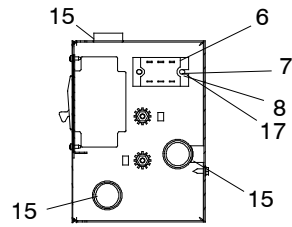

Top View of Box

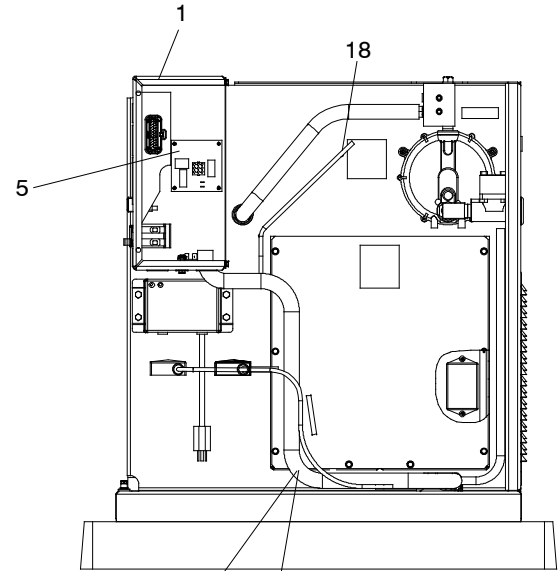
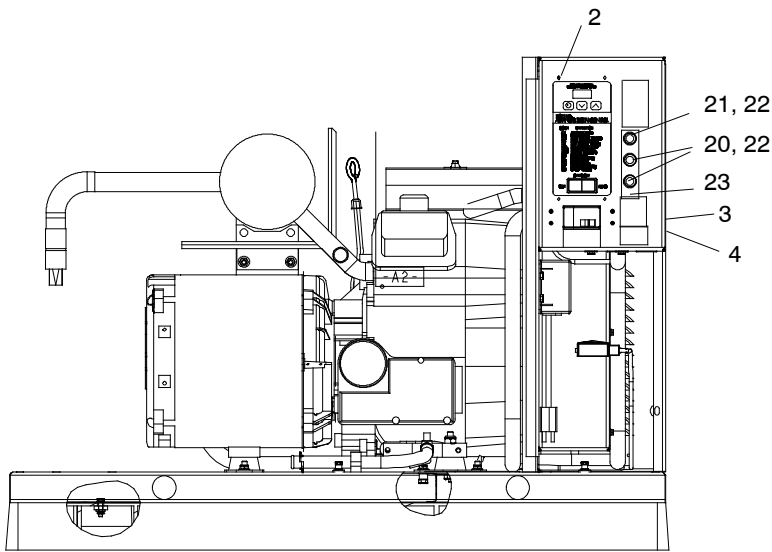
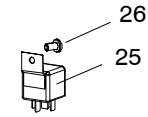

Ground Stud Location

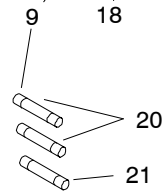
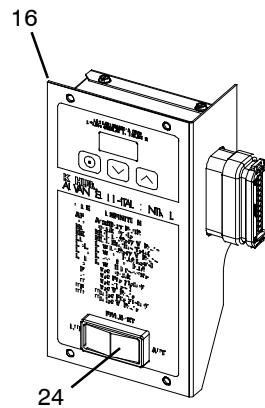
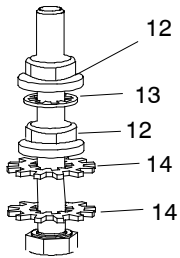

Group 301: Controller and Mounting, continued

Item	Part Number	Description	Qty.	
			53-8	53-14
1	GM29259	Housing, controller mtg. panel	1	1
2	X-50-15	Screw, slotted pan head machine	4	4
3	GM30226	Cover, controller	1	1
4	X-6216-1	Screw, Phillips hex crimplite	2	2
5	GM29671	Circuit board, relay board (12 V)	1	1
5	360459	Standoff, circuit board	4	4
6	GM28483	SCR module	1	1
7	X-51-5	Screw, slotted pan head machine 8-32 x 7/16	2	2
8	X-101-11	Nut, hex elastic stop, 8-32	4	4
9	GM49758	Harness, engine wiring (see note below)	1	1
12	M6923-06-08	Nut	2	2
13	X-22-11	Washer, lock, 0.262 ID x 0.469 OD	2	2
14	X-22-12	Washer, lock, 0.262 ID x 0.743 in. OD	4	4
15	X-634-27	Bushing	3	3
16	GM34969	Controller assembly, ADC 2100 (kit includes instructions)	1	1
17	X-25-118	Washer, plain, 0.406 ID x 1 in. OD	2	2
18	361567	Base, tie wrap snapin	3	3
19	233959	Diode, 6 A (not shown)	1	1
20	223316	Fuse, 10 A, 250 V (F2, F3)	2	2
21	292937	Fuse, 20 A, 250 V (F1)	1	1
22	238426	Fuse holder	3	3
23	GM39492	Decal, fuse panel	1	1
24	GM28708	Switch, rocker (part of item 16)	1	1
25	GM49746	Relay, 12 V	1	1
26	X-50-15	Screw, machine	1	1

Note:

Early 8.5/12RES models used a wiring harness (GM29352) with inline fuses. If replacing harness GM29352, order Harness Service Kit GM41872. Service Kit GM41872 includes harness GM49758 and items 20-23 for relocating the fuses to the junction box.

Group 301: Controller and Mounting, continued

8.5RES & 12RES ADC-RES Controller

Items not shown: 7, 30, 32

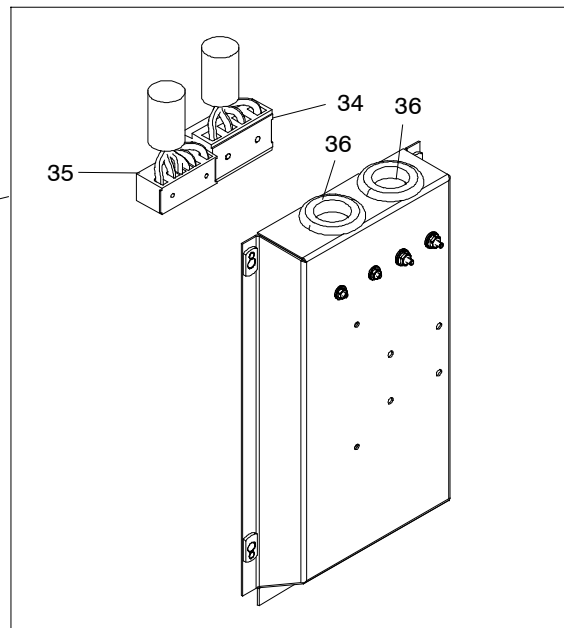
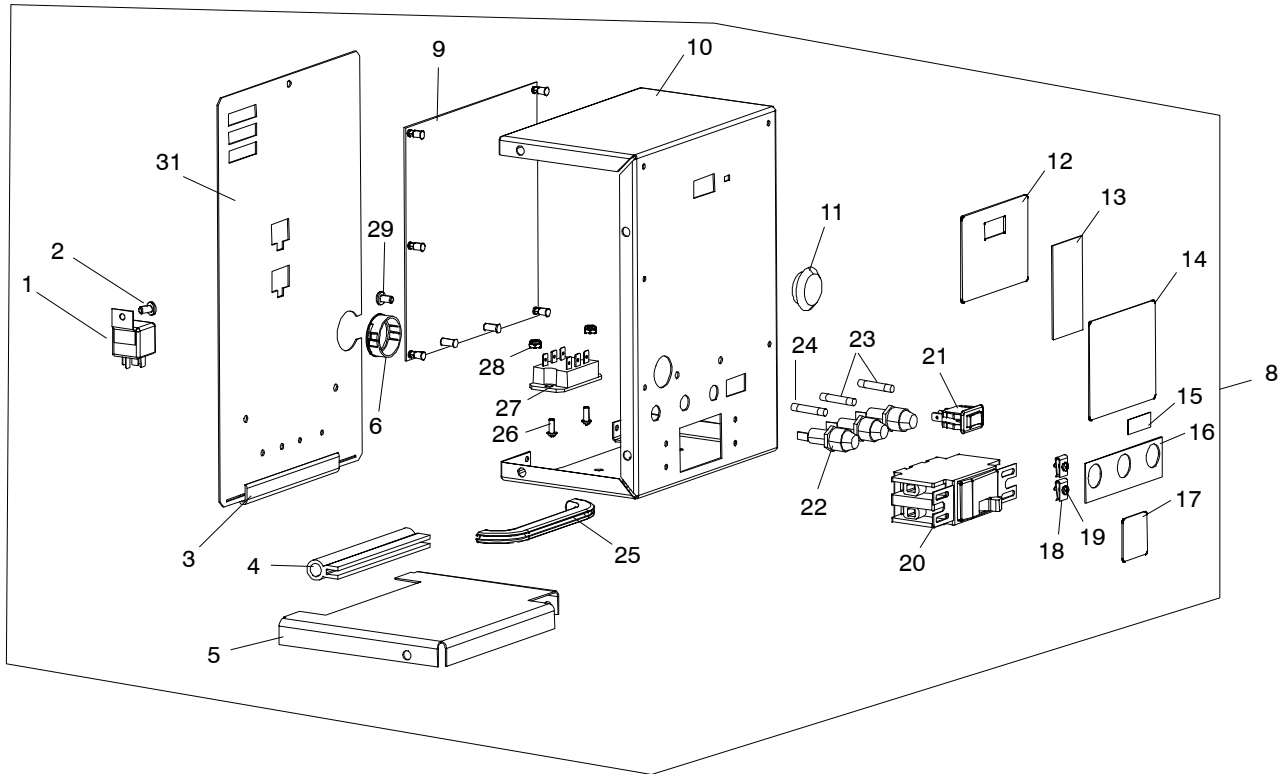

Group 301: Controller and Mounting, continued

Item	Part Number	Description	Qty.			
			Variation No.			
			53-19	53-20	53-35	53-38
1	GM49746	Relay, 12 VDC	1	1	1	1
2	X-50-15	Screw, machine	5	5	9	9
3	X-6047-41	Channel, U	1	1		
4	X-6422-31	Seal, push-on trim	1	1		
5	GM60625	Panel, junction box	1	1		
6	X-634-27	Bushing	1	1	2	2
7	361567	Base, tie wrap snapin	3	3	3	3
8	GM57149	Controller assembly (includes items 1-6, 9-29, 31, 32)	1			
8	GM57150	Controller assembly (includes items 1-6, 9-29, 31, 32)		1		
8	GM78184	Controller assembly (includes items 1-2, 6, 9-29, 31, 32)			1	
8	GM78183	Controller assembly (includes items 1-2, 6, 9-29, 31, 32)				1
9	GM49103	PCB assembly, advanced digital control	1	1	1	1
10	GM51847	Panel, controller mounting	1	1		
10	GM78182	Panel, controller mounting			1	1
11	X-301-43	Plug, button	1	1	1	1
12	GM52275	Switch, membrane overlay, 3-button	1	1	1	1
13	294520	Decal, danger, high voltage	1	1	1	1
14	GM53082	Decal, Fault Codes	1	1	1	1
15	GM53081	Decal, rocker switch	1	1	1	1
16	GM53080	Decal, fuse panel	1	1	1	1
17	GM53084	Decal, Power Breaker	1	1	1	1
18	239332	Clip, speed	4	4	4	4
19	X-67-143	Screw, cross recess, sheet metal	4	4	4	4
20	GM24928	Breaker, circuit	1			1
20	358384	Breaker, circuit		1	1	
21	GM70494	Switch, rocker on-off-on	1	1	1	1
22	238426	Fuse holder, 0.25 x 1.25 in.	3	3	3	3
23	223316	Fuse, 10 A, 250 V	2	2	2	2
24	292937	Fuse, 20 A, 250 V	1	1	1	1
25	X-6047-41	Channel, U	1	1		
26	X-51-5	Screw, machine	2	2	2	2
27	GM28483	SCR Module	1	1	1	1
28	X-101-11	Nut, hex elastic stop, 8-32	2	2	2	2
29	X-49-25	Screw, machine	2	2	2	2
30	GM51413	Harness, engine	1	1	1	1
31	GM51848	Cover, controller	1	1		
31	GM78181	Cover, controller			1	1
32	GM60175	Decal, Warning Non GFCI Outlet (not shown)	1	1	1	1
33	GM78202	Box, customer connection			1	1
34	GM78217	Harness, terminal block			1	1
35	GM78218	Harness, terminal block			1	1
36	X-284-3	Grommet, round			2	2

Group 301: Controller and Mounting, continued

12TRES 3 Phase Controller

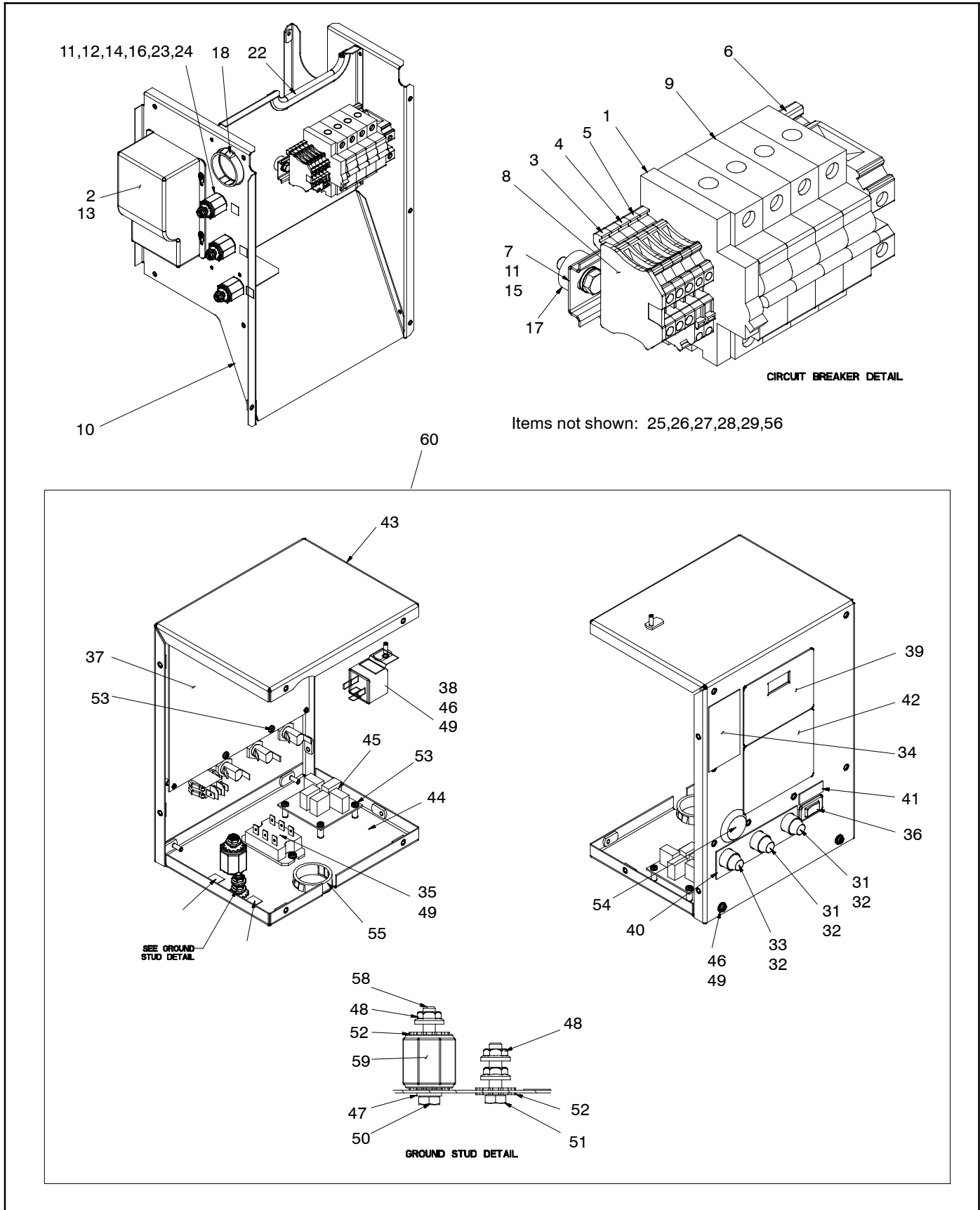

Group 301: Controller and Mounting, continued

Item	Part Number	Description	Qty.
			Variation No. 53-28
1	GB31613075201	Contact, auxiliary	1
2	GB31613430001	Charger, battery	1
3	GB31613529701	Block, terminal	2
4	GB31613529703	Block, terminal	1
5	GB31613529704	Block, terminal	2
6	GB31613529803	Block, terminal	1
7	GM47488	Rail, din	1
8	GM62786	Cover, terminal block	1
9	GM66027	Breaker, circuit 4 pole	1
10	GM66050	Box, junction	1
11	M125A-06-80	Washer, plain	5
12	M6923-06-80	Nut, Hex 6mm	3
13	M7985A-04016-20	Screw, pan head machine	4
14	M933-06010-60	Screw, hex cap	3
15	M933-06020-60	Screw, hex cap	2
16	X-22-12	Washer, lock, .262 ID x .743 in. OD	6
17	X-400-41	Spacer, .344 ID x .75 OD x .375 in.	2
18	X-634-18	Bushing	1
22	X-6047-41	Channel, "U"	1
23	X-6054-23	Stud (metric)	3
24	X-6128-35	Isolator, standoff	3
25	GM67080	Lead (not shown)	1
26	GM67081	Lead (not shown)	1
27	GM67082	Lead (not shown)	1
28	GM67083	Lead (not shown)	1
29	GM67084	Lead (not shown)	1
30	GM66066	Box Assembly, Junction (includes items 1-29)	1
31	223316	Fuse, 10 A, 250 V	2
32	238426	Fuse holder, .25 x 1.25 in.	3
33	292937	Fuse, 20 A, 250 V	1
34	294520	Decal, danger, high voltage	1
35	GM28483	SCR module	1
36	GM46103	Switch, rocker on-off-on	1
37	GM49103	PCB assy., Advanced Digital Control	1
38	GM49746	Relay, 12 VDC	1
39	GM52275	Switch, membrane overlay 3 button	1
40	GM53080	Decal, fuse panel	1
41	GM53081	Decal, rocker switch	1
42	GM53082	Decal, roc fault codes	1
43	GM69819	Panel, Controller Mounting (upper)	1
44	GM69820	Panel, Controller Mounting (lower)	1
45	GM69852	PCB Assy., CE filter	1
46	M125A-04-80	Washer, plain	3
47	M125A-06-80	Washer, plain	1
48	M6923-06-80	Nut, Hex 6mm	3
49	M7985A-04016-20	Screw, pan head machine	5
50	M933-06010-60	Screw, hex cap	1
51	M933-06025-60	Screw, hex cap	1
52	X-22-12	Washer, lock, .262 ID x .743 in. OD	4
53	X-49-25	Screw, machine	6
54	X-301-43	Plug, button, 1.37 (hole dia. 1.01)	1
55	X-634-28	Bushing	1
56	GM67078	Harness, engine (not shown)	1
58	X-6054-23	Stud (metric)	1
59	X-6128-35	Isolator, standoff	1
60	GM66048	Controller Assy. (includes items 31-55, 58, 59)	1

Group 501: Housing and Mounting

8.5RMY & 11RMY, Variation 1

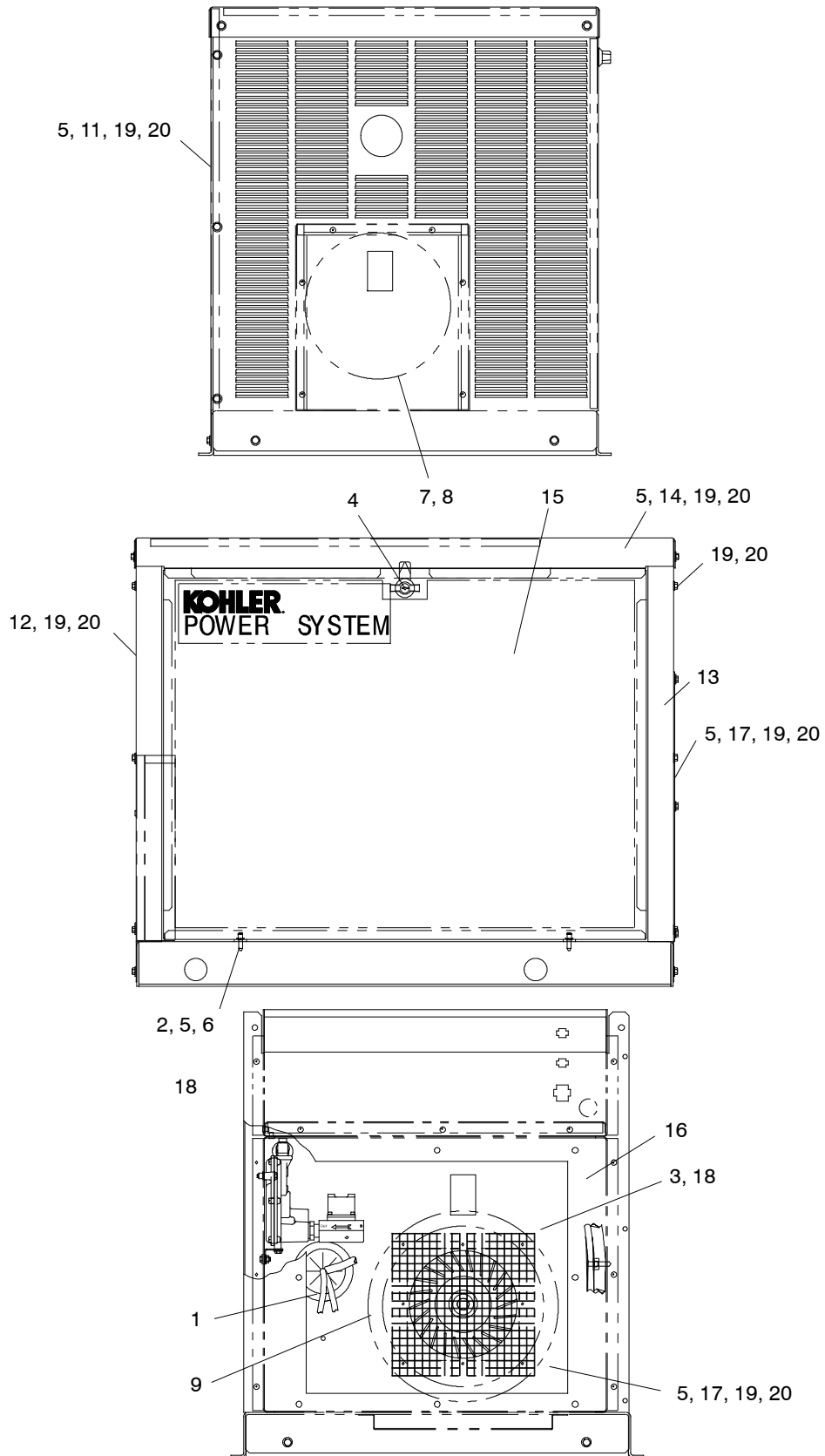

501-187-1

Group 501: Housing and Mounting

Item	Part Number	Description	Qty.
			Variation No. 1
1	X-284-31	Grommet, 3.00 ID	1
2	X-284-45	Grommet, 0.31 ID	2
3	X-6340-2	Clip, panel fastener	8
4	294515	Latch, locking	1
5	320828	Insert, threaded	17
6	345283	Pin, threaded	2
7	358084	Duct, air intake	1
8	358097	Seal, foam, 9.75 ID	1
9	358098	Seal, foam, 10.75 ID	1
10	358136	Kit, heat insulation	1
11	358138	Panel, rear	1
12	358139	Panel, alternator end	1
13	358140	Panel, engine end	1
14	358141	Panel, top	1
15	358142	Door, housing	1
16	358143	Duct, engine intake	1
17	358146	Panel, access	1
18	358227	Guard, air inlet	1
19	X-465-2	Bolt, hex cap, 1/4-20 x 0.625	17
20	#	Washer, plain, 1/4	17

Common hardware; procure locally.

Group 501: Housing and Mounting, continued

8.5RMY & 11RMY, Variations 4, GR9, 29-10

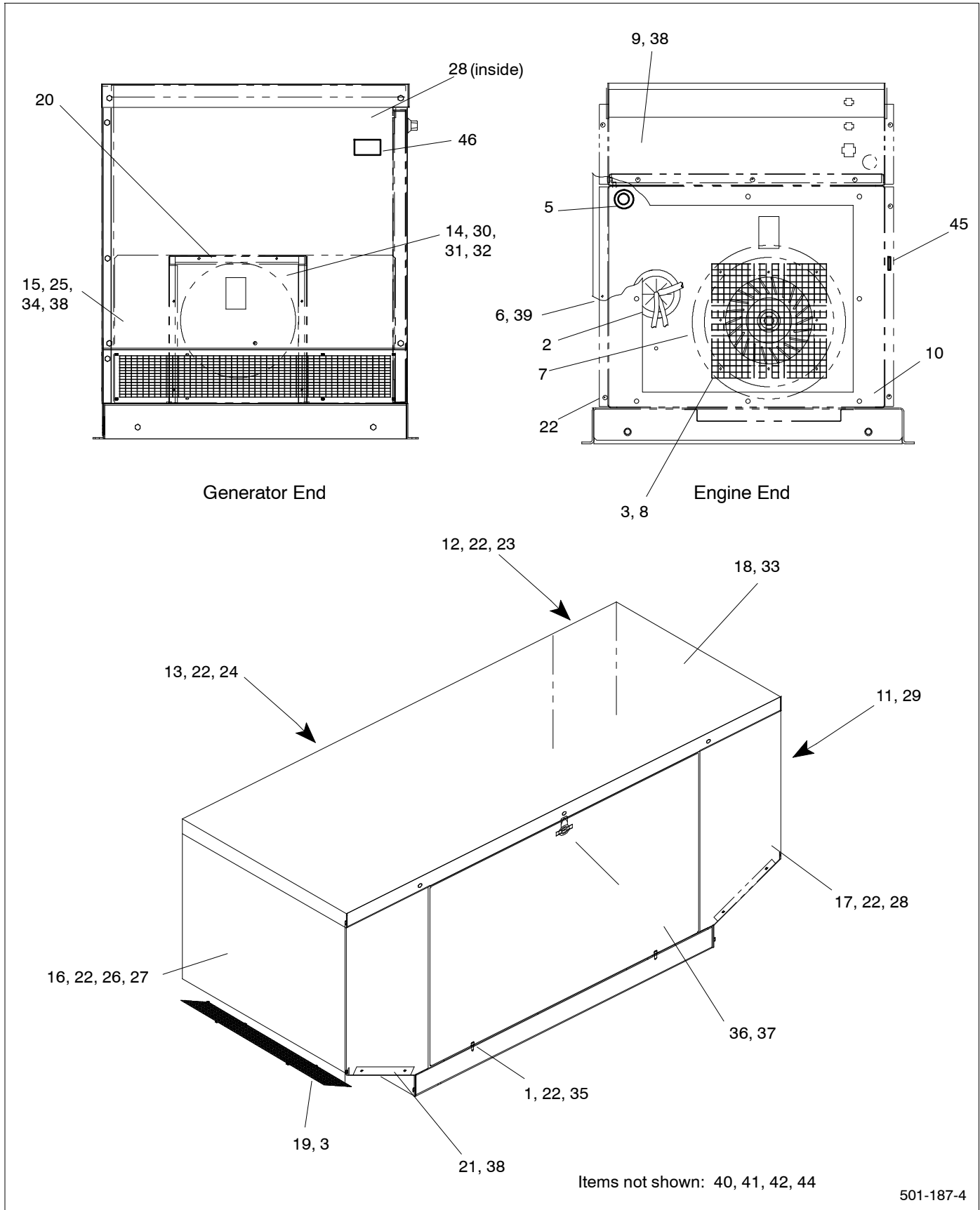

Group 501: Housing and Mounting, continued

Item	Part Number	Description	Qty.		
			Variation No.		
			4	GR9	29-10
1	X-284-45	Grommet, round	2	2	2
2	X-284-31	Grommet, round	1	1	1
3	X-6340-2	Clip, panel fastener	24	24	24
4	294515	Latch, locking	1	1	1
5	243488	Grommet, round	1	1	
5	X-284-3	Grommet, round			1
6	358143	Duct, engine intake	1	1	1
7	358098	Seal, foam	1	1	1
8	358227	Guard, air inlet	1	1	1
9	358389	Panel, access	1	1	1
10	358393	Panel, access	1	1	1
11	358395	Panel, access	1	1	1
12	358416	Duct, air, RS	1	1	1
13	358397	Panel, back	1	1	
13	GM24795	Panel, back			1
14	358391	Duct, air intake, mounting	1	1	
14	GM24793	Duct, air intake			1
15	358392	Duct, air intake, mounting	1	1	
15	GM24794	Duct, air intake			1
16	358394	Panel, alternator end, outer	1	1	1
17	358415	Duct, air, LS	1	1	1
18	358388	Panel, top	1	1	1
19	358396	Guard, air inlet	2	2	2
20	358097	Seal, foam	1	1	
21	358417	Duct, air, bottom	2	2	2
22	320828	Insert, threaded, 1/4-20 in.	25	25	25
23	GM10060	Insulation	2	2	
23	GM25911	Insulation			1
24	GM10040	Insulation, 35.75 x 25.75 cm	1	1	
24	GM25915	Insulation			1
25	GM10047	Insulation, 4.5 x 12.5 cm	1	1	
25	GM24797	Insulation			1
26	GM10051	Insulation	1	1	1
27	GM10059	Insulation	1	1	
27	GM25913	Insulation			1
28	GM10041	Insulation	1	1	
28	GM25914	Insulation			1
29	GM10042	Insulation, 20.38 x 20.38 cm	1	1	1
30	GM10045	Insulation, 12.38 x 11.5 cm	1	1	
30	GM24798	Insulation			1
31	GM10048	Insulation, 2 x 12.38 cm	1	2	1
31	GM24799	Insulation			2
32	GM10049	Insulation, 2 x 10.5 cm	2	1	1
32	GM25327	Insulation			1
33	GM10038	Insulation, 52 x 25 cm	1	1	
33	GM10038	Insulation (intake end)			1
33	GM25916	Insulation (exhaust end)			1
34	GM10044	Insulation, 24 x 11.5 cm	1	1	
34	GM25912	Insulation			1
35	345283	Pin, threaded	2	2	2
36	358142	Door, housing	1	1	1
37	GM10039	Insulation, 30.75 x 23.25 cm	1	1	1
38	X-781-14	Rivet, pop, .187 in.	20	20	24
39	X-781-15	Rivet, pop, .187 in.	4	4	4
40	X-781-11	Rivet, pop, .187 in. (not shown)	5	5	5
41	GM10137	Insulation, controller side, 7.5 x 85 cm (not shown)	1	1	1
42	GM10043	Insulation controller back, 19 x 8.5 cm (not shown)	1	1	1
43	GM10046	Insulation, 7.5 x 12.5 cm	1	1	1
44	X-301-45	Plug, button (not shown)	1	1	4
45	X-634-16	Bushing, 1.312 x 1.50 in. NPT		2	2
46	GM15299	Decal, rainproof enclosure		1	1

Group 501: Housing and Mounting, continued

8.5RES & 12RES

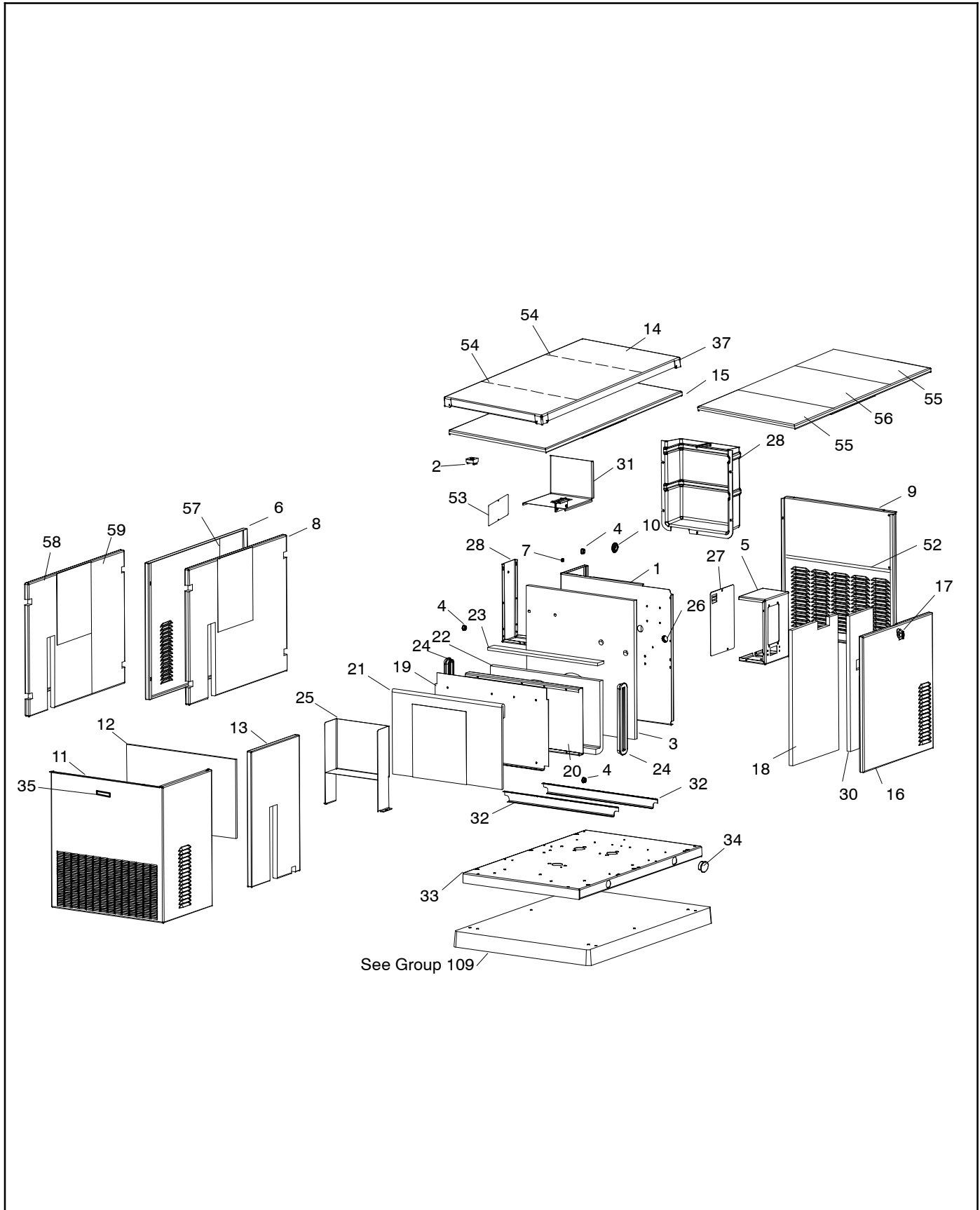

Group 501: Housing and Mounting, continued

Item	Part Number	Description	Quantity			
			Variation/Module			
			53-9	GM60800-MA1	GM60800-MA5	GM60800-MA8
1	GM29258	Housing, air intake duct (used with ADC 2100 controller)	1			
1	GM55419	Housing, air intake duct (used with ROC controller)	1	1	1	
1	GM78212	Housing, air intake duct				1
2	X-6204-10	Retainer, nut	5	5	5	5
3	GM29270	Insulation	1	1	1	1
4	X-301-24	Plug, button	4	4	4	4
5	—	Housing, controller mounting panel (see Group 301)	1	1	1	1
6	GM29261	Housing, side panel	1	1	1	1
7	GM11040-2	Insert, threaded (metric) 6 mm	6	6	6	6
8	GM29269	Insulation	1			
9	GM29259	Housing, front panel (used with ADC 2100 controller)	1			
9	GM55417	Housing, front panel (used with ROC controller)	1	1		
9	GM66786	Panel assembly, breaker (includes items 38-51)			1	
9	GM78220	Housing, front panel				1
10	X-284-3	Grommet, round	1	1	1	1
11	GM29260	Housing, rear panel	1	1	1	1
12	GM29271	Insulation	1	1	1	1
13	GM29268	Insulation	1	1	1	1
14	GM29262	Housing, roof	1	1	1	1
15	GM29350	Insulation	1			
16	GM45921-KA3	Door assembly (standard, includes 1 latch)	1	1		1
16	GM45921-KA1	Door assembly (high wind, includes 2 latches)	1	1	1	1
17	294515	Latch, locking	1	1	1	1
17	362361	Key, Latch	1	1	1	1
18	GM29355	Insulation	1	1	1	1
19	GM62354	Duct, alternator air	1	1	1	1
20	GM62357	Duct, alternator air	1	1	1	1
21	GM39591	Insulation	1	1	1	1
22	GM39592	Insulation	1	1	1	1
23	GM39593	Insulation	1	1	1	1
24	X-6422-20	Seal, push-on trim	2	2		2
25	GM29357	Shield, exhaust	1	1	1	1
26	X-634-27	Bushing	1	1	1	1
27	—	Cover, controller (see Group 301)	1	1	1	1
28	GM38809	Duct, engine air intake	1	1	1	1
30	GM30937	Insulation, door	1	1	1	1
31	GM29983	Shield, heat	1	1	1	1
32	GM22982	Channel, base support	2	2		
33	—	Base (see Group 109)	1	1	1	1
34	X-301-45	Plug, button	4	4	4	4
35	GM15299	Decal, rainproof enclosure	1	1	1	1
36	GM31074-1	Bushing, molded (not shown)	2	2		
37	GM42840	Corner, sound shield (KCB)	4	4	4	4
52	GM58719	Support, side		1		1
53	GM78206	Cover, customer connection				1
54	GM78100	Support, roof		2	2	2
55	GM78104	Insulation		2	2	2
56	GM78105	Insulation		1	1	1
57	GM78101	Support, side		1	1	1
58	GM78106	Insulation		1	1	1
59	GM78107	Insulation		1	1	1

Group 501: Housing and Mounting, continued

8.5RES & 12RES

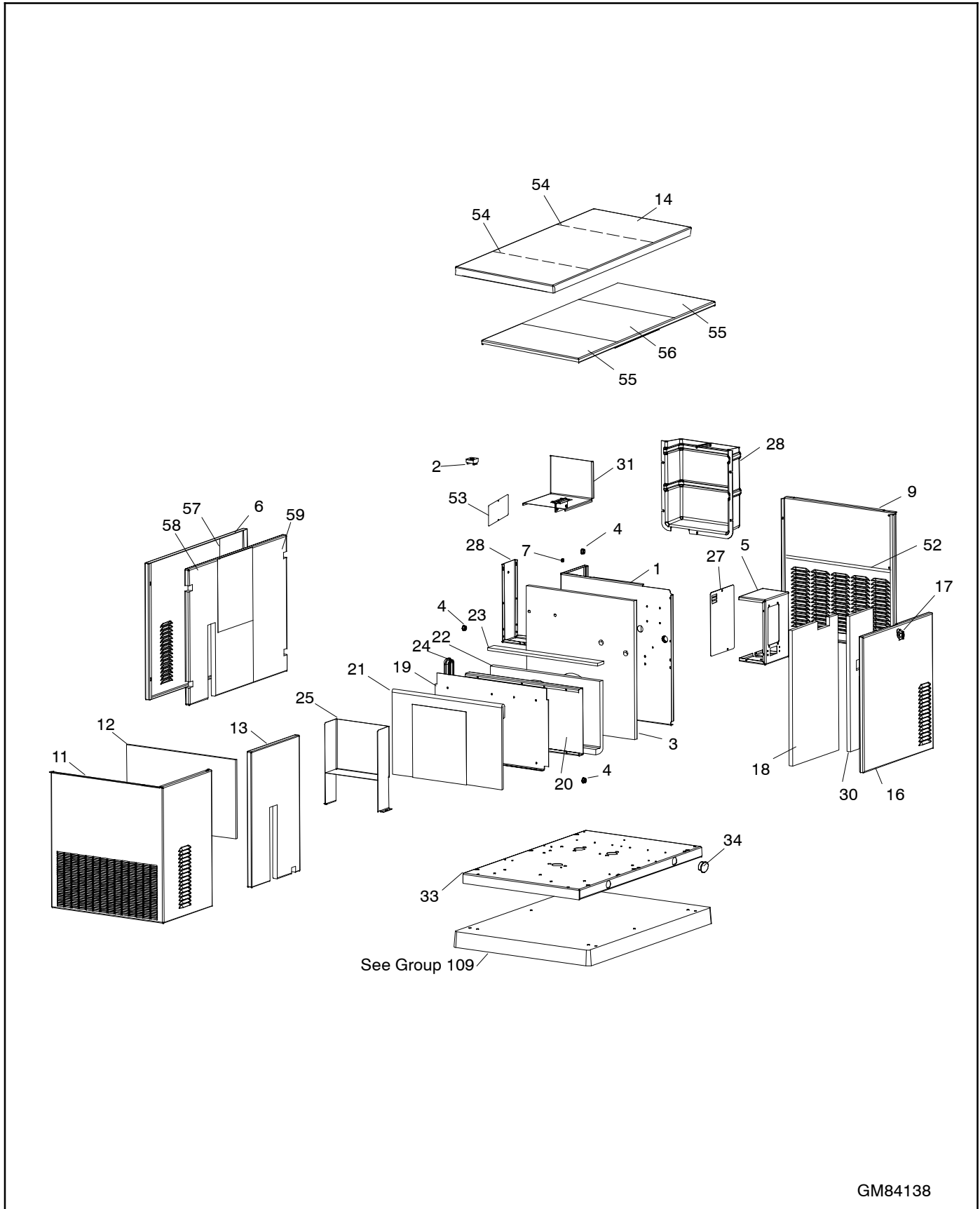

GM84138

Group 501: Housing and Mounting, continued

Item	Part Number	Description	Quantity	
			Module	
			GM84138-MA2**	GM84138-MA3**
1	GM84024**	Housing, air intake duct	1	1
2	X-6204-10	Retainer, nut	5	5
3	GM29270	Insulation	1	1
4	X-301-24	Plug, button	4	4
5	—	Housing, controller mounting panel (see Group 301)	1	1
6	GM84025**	Housing, side panel	1	1
7	GM11040-7	Insert, threaded (M6 x 1.0 Hex)	6	6
9	GM84028**	Panel assembly, breaker (includes items 38-51)	1	
9	GM84030**	Housing, front panel		1
11	GM84026**	Housing, rear panel	1	1
11	GM84865**	Grill, Exhaust (not shown)	1	1
12	GM29271	Insulation	1	1
13	GM29268	Insulation	1	1
14	GM84031**	Housing, roof	1	1
16	GM84139-KA2**	Door assembly (standard, includes 1 latch)	1	1
16	GM84139-KA1**	Door assembly (high wind, includes 2 latches)	1	1
17	294515	Latch, locking	1	1
17	362361	Key, Latch	1	1
18	GM29355	Insulation	1	1
19	GM84033	Duct, alternator air	1	1
20	GM84032	Duct, alternator air	1	1
21	GM39591	Insulation	1	1
22	GM39592	Insulation	1	1
23	GM39593	Insulation	1	1
25	GM29357	Shield, exhaust	1	1
27	GM78181	Cover, controller	1	1
28	GM38809	Duct, engine air intake	1	1
30	GM30937	Insulation, door	1	1
31	GM29983	Shield, heat	1	1
33	—	Base (see Group 109)	1	1
34	X-301-45	Plug, button	4	4
52	GM58719	Support, side		1
53	GM78206	Cover, customer connection	1	1
54	GM78100	Support, roof	2	2
55	GM78104	Insulation	2	2
56	GM78105	Insulation	1	1
57	GM78101	Support, side	1	1
58	GM78106	Insulation	1	1
59	GM78107	Insulation	1	1
60	X-6033-8	Grommet, U-channel	1	1

** Add a suffix to this color dependent part number before ordering.
See chart below to identify the color suffix.

Kit No.	Color Dependent Parts	
	Part Number Suffix	Part Number Example (item 1)
GM84138-MA2-CAS	-CAS	GM84024-CAS
GM84138-MA3-CAS	-CAS	GM84024-CAS

Group 501: Housing and Mounting, continued

12RES GM96478-MA1

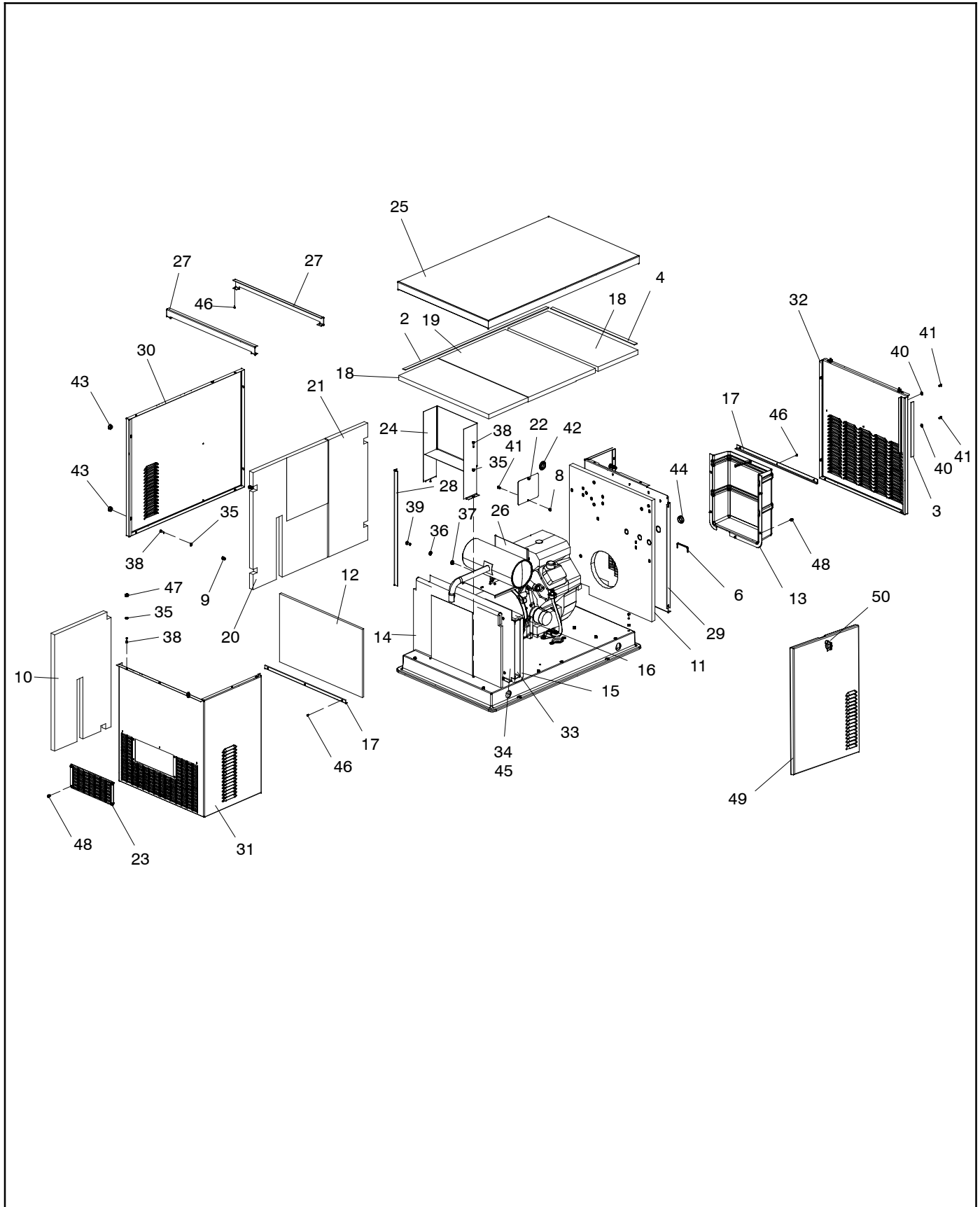

Group 501: Housing and Mounting, continued

Item	Part Number	Description	Quantity
			Module GM96478-MA1
2	X-6031-7	Insulation, Adhesive Backed Foam	1
3	X-6031-23	Insulation, ADH Backed Foam	1
4	X-6031-24	Insulation, ADH Backed Foam	1
6	X-6033-8	Grommet, U Channel	1
8	346258	Insert, threaded, #10-24	2
9	GM11040-7	Insert, Threaded (M6 x 1.0 Hex)	6
10	GM29268	Insulation	1
11	GM29270	Insulation	1
12	GM29271	Insulation	1
13	GM38809	Duct, Engine Air Intake	1
14	GM39591	Insulation	1
15	GM39592	Insulation	1
16	GM39593	Insulation	1
17	GM58719	Support, Side	2
18	GM78104	Insulation	2
19	GM78105	Insulation	1
20	GM78106	Insulation	1
21	GM78107	Insulation	1
22	GM78206	Cover, Customer Connection	1
23	GM84865	Grill, Exhaust	1
24	GM90666	Shield, Exhaust	1
25	GM96859	Panel, Roof	1
26	GM96903	Shield, Heat	1
27	GM96904	Support, Roof	2
28	GM96905	Support, Side	1
29	GM96907	Panel, Intake	1
30	GM96908	Panel, Side	1
31	GM96909	Panel, Rear	1
32	GM96910	Panel, Front	1
33	GM96912	Duct, Alternator Air Inlet	1
34	GM96913	Duct, Alternator Air Wall	1
35	M125A-06-80	Washer, Plain	23
36	M125A-08-80	Washer, Plain 8.4 ID x 16.0 OD	2
37	M6923-08-80	Nut, Hex 8mm	2
38	M933-06020-60	Screw, hex cap	25
39	M933-08020-60	Screw, hex cap	2
40	X-25-36	Washer,plain, .219 ID x .5 in. OD	4
41	X-50-15	Screw, Machine	4
42	X-284-3	Grommet, round	1
43	X-301-24	Plug,button	4
44	X-634-27	Bushing	2
45	X-781-14	Rivet, pop, .187 in. ALUM	7
46	X-793-3	Rivet, pop, .125 in.	13
47	X-6204-10	Retainer, Nut	6
48	X-6216-1	Screw, Phillips hex crimpite	9
49	GM84139-KA2-CAS	Door assembly (standard, includes 1 latch)	1
49	GM84139-KA1-CAS	Door assembly (high wind, includes 2 latches)	1
50	294515	Latch, locking	1
50	362361	Key, Latch	1

Group 501: Housing and Mounting, continued

12TRES 3 Phase Controller

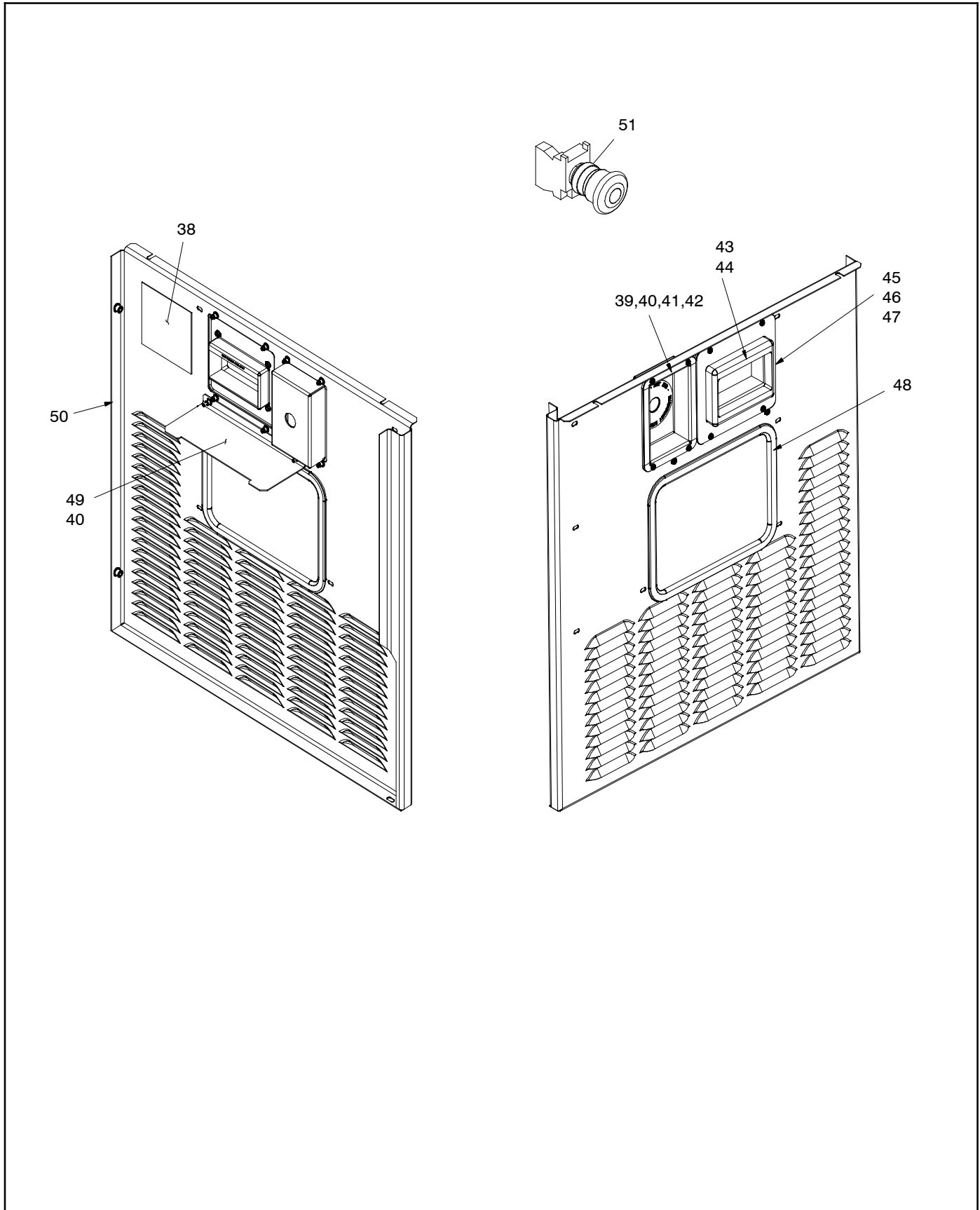

Group 501: Housing and Mounting, continued

Item	Part Number	Description	Quantity	
			GM60800-MA5	GM84138-MA2**
9	GM66786	Panel assembly, breaker (includes items 38-50)	1	
9	GM84028**	Panel assembly, breaker (includes items 38-50)		1
38	229883	Decal, 12 wire reconnection	1	1
39	GB31311173101	Decal, emergency stop	1	1
40	M7985A-004016-20	Screw, pan head machine	6	6
41	GM65464-1	Gasket, E-stop	1	1
42	GM64282	Panel, E-Stop mounting	4	4
43	X-67-59	Screw, hex washer, thread-forming	1	1
44	GM66609	Window, enclosure	1	1
45	GM69619	Panel, breaker mounting	1	1
46	M7985A-04016-20	Screw, pan head machine	4	4
47	GM65464-2	Gasket, circuit breaker	1	1
48	23370 00102	U channel, black PVC 1/8	1	1
49	GM60731	Panel, access	1	1
50	GM60727	Housing, front panel	1	
50	GM84029**	Housing, front panel		1
51	GB31613392201	Switch, emergency stop	1	1

** Add a suffix to this color dependent part number before ordering.
See chart below to identify the color suffix.

Kit No.	Color Dependent Parts	
	Part Number Suffix	Part Number Example (item 1)
GM84138-MA2-CAS	-CAS	GM84024-CAS
GM84138-MA3-CAS	-CAS	GM84024-CAS

Group 701: Literature

Item	Part Number	Description	Qty.							
			Variation No.							
			7	9	11	13	20	43	49	92
1	24 690 06	S/M, CH18-CH750 COMMAND TWIN	1	1	1	1	1	1	1	1
2	TP-5865	Operation Manual, 8.5/11RMY	1	1						
2	TP-6049	Operation Manual, 8.5/11RMY (sound enclosure models)	1	1	1					
2	TP-6331	Operation Manual, 8.5/12RES				1				
2	TP-6515	Operation Manual, 8.5/12/17/RES					1	1	1	1
3	TP-5867	Service Manual, 8.5/11RMY	1	1	1					
3	TP-6196	Service Manual, 8.5/12RES				1	1	1	1	1
4	TP-5868	Parts Catalog, 8.5/11RMY & 8.5/12RES	1	1	1	1	1	1	1	1
5	TP-6328	Installation Manual, 8.5/12RES				1				
5	TP-6514	Installation Manual, 8.5/12/17/RES					1	1		
5	TP-6792	Installation Manual, 8.5/12/17/RES							1	
5	TP-6967	Installation Manual, 12RES								1
6	TP-5374	Warranty, 1-Year Limited	1	1	1					
6	TP-5762	Warranty, California Emission	1							
6	TP-6168	Warranty, Federal/CA Emission		1	1	1	1	1		
6	TP-6479	Warranty, 5-Year Limited, 8.5-30RES				1	1	1	1	1
6	TP-6782	Warranty, 2011 Emissions, Residential				1	1	1	1	
6	TP-6766	Warranty, Residential/Light Commercial								1
6	TP-6884	Warranty, CARB/EPA Emissions, SORE								1

Kit Parts List

Qty.	Description	Part No.
------	-------------	----------

Fuel System Kit

Gas Strainer PA-290275		
1	Strainer, gas	292485
Flexible Fuel Line GM31054-KP1		
1	Fuel line, flexible, 0.50 in. ID x 12 in.	X-504-1

Exhaust System Kit

Flexible Exhaust Connector PA-358226		
1	Clamp, muffler, 2.12 in.	X-722-5
1	Clamp, muffler, 1.37 in.	X-722-8
1	Hose, flexible exhaust	X-797-41

Exhaust Elbow and Guard (for units without sound shields)

GM10671-KP1		
1	Clamp, muffler, 1.37 in.	X-722-8
4	Screw, hex washer, thread-forming	X-67-133
1	Guard, exhaust	GM10792
1	Arrester, spark	GM39500
1	Fitting, elbow, exhaust	337332
1	Installation instructions	TT-1255

Electrical System Kits

Battery PA-324553		
1	Battery, wet charged	324367

Battery GM48808-KA1		
1	Battery, (wet)	GM48787

Battery Heater PA-358225		
1	Installation Instructions	TT-1221
1	Heater, battery wrap	336814
1	Heater, battery pad	336825

Battery Heater,120VAC,110W GM89022-KP1		
1	Installation Instructions	TT-1221
1	Heater, battery wrap	336814
1	Heater, battery pad	336825

Battery Charger, Float 12 V, 6 A GM11849-KP1		
1	Battery charger, 12 V, 6 A float-equalize	GM11849

Qty.	Description	Part No.
------	-------------	----------

Battery Charger, Trickle Charger

PAA-248952

1	Installation Instructions	TT-938
1	Battery charger assembly	A-248952
	Includes the following:	
1	Terminal	X-283-8
2	Block, terminal	X-405-2
1	Terminal, female	X-431-27
9	Terminal, female	X-431-28
2	Connector, non-metallic	X-567-1
4	Screw, drill	X-794-2
1	Holder, fuse	238426
1	Cord, power	246185
1	Cover, battery charger	246604
1	Ammeter, DC	269202
1	Transformer	269204
4	Spacer, screen	270833
1	Fuse, 1.5 A	291207
1	Lamp	291208
1	Resistor	291209
1	Switch, high/low slide	291210
1	Switch, 12/24 V slide	291211
1	Rectifier, silicon	291212
1	Resistor	291213
1	Cable, positive	291215
1	Cable, negative	291216
1	Nameplate, part number	291221
1	Breaker, circuit	291265
1	Rheostat	291975
1	Box battery charger	325389

Battery Charger, Equalize/Float

PAD-292862

1	Installation Instructions	TT-680
1	Installation Instructions, circuit board	TT-729
1	Battery charger assembly	D-292862
	Includes the following:	
1	Board, circuit	C-262377
2	Terminal, ring, 4-6 screw	X-283-1
2	Terminal, ring, 8-10 screw	X-283-11
3	Terminal, ring, 6-8 screw	X-283-2
2	Tubing, heat shrink	X-6081-3
1	Decal, connection	233966
1	Fuse, 5 A	239298
2	Clip, speed	257442
1	Fuse, 25 A	262389
2	Holder, fuse	263156
1	Transformer	262394
1	Decal, warning	262397
1	Clip, cable	262399
2	Holder, fuse	263156
4	Spacer, circuit board	287948
1	Lamp	291208
1	Decal, explosion battery gases	292387
1	Sink, heat	292938
1	Strip, terminal	292940
1	Ammeter, DC	292941
1	Voltmeter, DC	292942
1	Module, SCR	292945
1	Resistor, power	292947
1	Fuse, 7 A	292948
1	Harness, wiring	292958
1	Marker, strip	292961
1	Marker, strip	292962
2	Retainer	295010
1	Block, terminal	295314
4	Nut, captive	298810
1	Box, battery charger	325593
1	Door, silkscreen	325596
1	Nameplate	325609

Kit Parts List

Qty.	Description	Part No.
------	-------------	----------

Battery Charger, Equalize/Float (with alarms)

PAD-292863

1	Installation Instructions	TT-680
1	Installation Instructions, circuit board	TT-729
1	Battery charger assembly Includes the following:	D-292863
1	Board, circuit alarm	B-262374
1	Board, circuit	C-262377
2	Terminal, ring, 4-6 screw	X-283-1
2	Terminal, ring, 8-10 screw	X-283-11
3	Terminal, ring, 6-8 screw	X-283-2
2	Tubing, heat shrink	X-6081-3
1	Decal, connection	233966
1	Fuse, 5 A	239298
2	Clip, speed	257442
1	Fuse, 25 A	262389
1	Transformer	262394
1	Decal, warning	262397
1	Clip, cable	262399
2	Holder, fuse	263156
4	Spacer, circuit board	287948
1	Lamp	291208
1	Decal, explosion battery gases	292387
1	Sink, heat	292938
1	Strip, terminal	292940
1	Ammeter, DC	292941
1	Voltmeter, DC	292942
1	Module, SCR	292945
1	Resistor, power	292947
1	Fuse, 7 A	292948
1	Harness, wiring	292958
1	Marker, strip	292961
1	Marker, strip	292962
1	Retainer	295010
1	Block, terminal	295314
4	Nut, captive	298810
1	Box, battery charger	325593
1	Door, silkscreen	325596
1	Nameplate	325609

Relay, Run

PA-273743

4	Washer, plain	X-25-9
1	Tie, cable	X-468-1
2	Screw, pan head machine, #6-32 x 0.50	X-49-26
2	Nut, hex, #6-32	X-6210-3
1	Relay assembly	273705
1	Installation instructions	TT-700

Relay, Fault

358371

1	Screw, slotted pan head machine	X-50-1
1	Relay, 12 VDC, .20 A	259391
1	Harness, fault relay kit	358375

Run/Common Fault Relay, 12 V ADC 2100

GM30414-KP1

1	PCB assembly, relay board 12 V	GM29779
1	Harness, wiring relay board	GM30539
1	Installation Instructions	TT-1423

Run/Common Fault Relay, 12 V ADC-RES

GM53102-KA1

4	Standoff, circuit board	360459
1	PCB Assy., relay interface board	GM51403
1	Harness, wiring relay board	GM52639

Harness, 25', Remote Panel

GM32333-KP2

1	Harness, Extension	GM32323
---	--------------------	---------

Harness, 100' Remote Panel

GM32333-KP4

1	Harness, Extension	GM47391
---	--------------------	---------

Qty.	Description	Part No.
------	-------------	----------

Harness, 25', Remote Panel

GM32333-KP7-QS

1	Harness, Extension	GM32323
---	--------------------	---------

Harness, 100' Remote Panel

GM32333-KP8-QS

1	Harness, Extension	GM47391
---	--------------------	---------

Terminal Block

GM58022-KA1

2	Harness, pigtail customer connection	GM48108
1	Block, terminal 4 pos.	GM54818
1	Terminal block, 6 pos.	GM54819
1	Decal, terminal block	GM54820
1	Harness, terminal block	GM54821

Miscellaneous Kits

Air Outlet Duct Flange

PA-226932

4	Washer, plain	X-25-36
4	Screw, RHM, 10-24 x 5/8	X-50-8
4	Nut, 10-24	X-6210-5
8	Rivet, pop	X-781-11
2	Flange, air duct, sides	226930
2	Flange, air duct, top/bottom	226931

Block Heater

GM16284-KA1

1	Heater, block	GM16283
---	---------------	---------

Carburetor Heater 120 V

GM19462-KP1-QS

1	Heater, inlet 37 W, 120 V	GM19463
1	Tube, breather, 0.375 in. OD, copper	GM19464
1	Insulator, breather line	GM19465
1	Decal, caution hot carburetor	GM22387
1	Plug, button	X-301-23
4	Screw, hex head	X-97-22
1	Installation instructions	TT-1297

Carburetor Heater 12 VDC

GM21285-KP1

2	Cover, blower housing	24 096 17
1	Tube, breather, 0.375 in. OD, copper	GM19464
1	Insulator, breather line	GM19465
1	Heater, plate 37 W, 12 V	GM21278
1	Diode assembly	GM21283
1	Decal, caution hot carburetor	GM22387
1	Washer, plain, 0.188 ID x 0.438 in. OD	X-25-48
1	Plug, button	X-301-23
1	Screw, cross recess pan head machine	X-49-6
1	Nut, flange whiz, 6-32	X-6210-3
2	Screw, hex washer head, drill	X-794-2
4	Screw, hex head	X-97-22
1	Installation instructions	TT-1313

Carburetor Heater 12 VDC

GM63550-KA1

1	Tube, breather, 0.375 in. OD, copper	GM19464
1	Insulator, breather line	GM19465
1	Decal, caution hot carburetor	GM22387
1	Heater, plate 37 W, 240 V	GM63544
1	Plug, button	X-301-23
4	Screw, hex head	X-97-22
1	Installation instructions	TT-1297

Maintenance Service Kits

(includes oil, oil filter, air filter, spark plugs, and instructions (TT-1445))

1	Kit, Residential Maint (8.5RES)	GM62345-SKP1-QS
1	Kit, Residential Maint (12RES)	GM62346-SKP1-QS

Kit Parts List

Qty.	Description	Part No.
Software, OnCue		GM62630-KP3
1	Decal, Terminal Block	GM54820
1	Assy, J1939/ModBus/Ethernet Converter	GM58703
1	Harness, Y-Connector 8.5-17KW	GM62626
1	Harness	GM62627
1	Software, OnCue	GM62628
1	Diagram, Wiring Network Communications	GM62629
1	Panel Assy, Junction Box	GM66795
2	Washer, Plain	M125A-04-80
2	Screw, Pan Head Machined	M7985A-04010-20
2	Nut, Hex 4mm	M934-04-50
1	O/M OnCue Software, Res/Coml	TP-6616
1	TT Network Connection, OnCue, Res/Coml	TT-1486

Appendix A Abbreviations

The following list contains abbreviations that may appear in this publication.

A, amp	ampere	cfm	cubic feet per minute	ext.	external
ABDC	after bottom dead center	CG	center of gravity	F	Fahrenheit, female
AC	alternating current	CID	cubic inch displacement	fglass.	fiberglass
A/D	analog to digital	CL	centerline	FHM	flat head machine (screw)
ADC	advanced digital control; analog to digital converter	cm	centimeter	fl. oz.	fluid ounce
adj.	adjust, adjustment	CMOS	complementary metal oxide substrate (semiconductor)	flex.	flexible
ADV	advertising dimensional drawing	cogen.	cogeneration	freq.	frequency
Ah	amp-hour	com	communications (port)	FS	full scale
AHWT	anticipatory high water temperature	coml	commercial	ft.	foot, feet
AISI	American Iron and Steel Institute	Coml/Rec	Commercial/Recreational	ft. lb.	foot pounds (torque)
ALOP	anticipatory low oil pressure	conn.	connection	ft./min.	feet per minute
alt.	alternator	cont.	continued	ftp	file transfer protocol
Al	aluminum	CPVC	chlorinated polyvinyl chloride	g	gram
ANSI	American National Standards Institute (formerly American Standards Association, ASA)	crit.	critical	ga.	gauge (meters, wire size)
AO	anticipatory only	CRT	cathode ray tube	gal.	gallon
APDC	Air Pollution Control District	CSA	Canadian Standards Association	gen.	generator
API	American Petroleum Institute	CT	current transformer	genset	generator set
approx.	approximate, approximately	Cu	copper	GFI	ground fault interrupter
AQMD	Air Quality Management District	cUL	Canadian Underwriter's Laboratories	GND, Ⓧ	ground
AR	as required, as requested	CUL	Canadian Underwriter's Laboratories	gov.	governor
AS	as supplied, as stated, as suggested	cu. in.	cubic inch	gph	gallons per hour
ASE	American Society of Engineers	cw.	clockwise	gpm	gallons per minute
ASME	American Society of Mechanical Engineers	dB	decibel	gr.	grade, gross
assy.	assembly	dB(A)	decibel (A weighted)	GRD	equipment ground
ASTM	American Society for Testing Materials	DC	direct current	gr. wt.	gross weight
ATDC	after top dead center	DCR	direct current resistance	H x W x D	height by width by depth
ATS	automatic transfer switch	deg., °	degree	HC	hex cap
auto.	automatic	dept.	department	HCHT	high cylinder head temperature
aux.	auxiliary	DFMEA	Design Failure Mode and Effects Analysis	HD	heavy duty
avg.	average	dia.	diameter	HET	high exhaust temp., high engine temp.
AVR	automatic voltage regulator	DI/EO	dual inlet/end outlet	hex	hexagon
AWG	American Wire Gauge	DIN	Deutsches Institut für Normung e. V. (also Deutsche Industrie Normenausschuss)	Hg	mercury (element)
AWM	appliance wiring material	DIP	dual inline package	HH	hex head
bat.	battery	DPDT	double-pole, double-throw	HHC	hex head cap
BBDC	before bottom dead center	DPST	double-pole, single-throw	HP	horsepower
BC	battery charger, battery charging	DS	disconnect switch	hr.	hour
BCA	battery charging alternator	DVR	digital voltage regulator	HS	heat shrink
BCI	Battery Council International	E, emer.	emergency (power source)	hsg.	housing
BDC	before dead center	ECM	electronic control module, engine control module	HVAC	heating, ventilation, and air conditioning
BHP	brake horsepower	EDI	electronic data interchange	HWT	high water temperature
blk.	black (paint color), block (engine)	EFR	emergency frequency relay	Hz	hertz (cycles per second)
blk. htr.	block heater	e.g.	for example (<i>exempli gratia</i>)	IC	integrated circuit
BMEP	brake mean effective pressure	EG	electronic governor	ID	inside diameter, identification
bps	bits per second	EGSA	Electrical Generating Systems Association	IEC	International Electrotechnical Commission
br.	brass	EIA	Electronic Industries Association	IEEE	Institute of Electrical and Electronics Engineers
BTDC	before top dead center	EI/EO	end inlet/end outlet	IMS	improved motor starting
Btu	British thermal unit	EMI	electromagnetic interference	in.	inch
Btu/min.	British thermal units per minute	emiss.	emission	in. H ₂ O	inches of water
C	Celsius, centigrade	eng.	engine	in. Hg	inches of mercury
cal.	calorie	EPA	Environmental Protection Agency	in. lb.	inch pounds
CAN	controller area network	EPS	emergency power system	Inc.	incorporated
CARB	California Air Resources Board	ER	emergency relay	ind.	industrial
CB	circuit breaker	ES	engineering special, engineered special	int.	internal
cc	cubic centimeter	ESD	electrostatic discharge	int./ext.	internal/external
CCA	cold cranking amps	est.	estimated	I/O	input/output
ccw.	counterclockwise	E-Stop	emergency stop	IP	iron pipe
CEC	Canadian Electrical Code	etc.	et cetera (and so forth)	ISO	International Organization for Standardization
cert.	certificate, certification, certified	exh.	exhaust	J	joule
cfh	cubic feet per hour			JIS	Japanese Industry Standard

KBus	Kohler communication protocol	MW	megawatt	rnd.	round
kg	kilogram	mW	milliwatt	ROM	read only memory
kg/cm ²	kilograms per square centimeter	μF	microfarad	rot.	rotate, rotating
kgm	kilogram-meter	N, norm.	normal (power source)	rpm	revolutions per minute
kg/m ³	kilograms per cubic meter	NA	not available, not applicable	RS	right side
kHz	kilohertz	nat. gas	natural gas	RTU	remote terminal unit
kJ	kilojoule	NBS	National Bureau of Standards	RTV	room temperature vulcanization
km	kilometer	NC	normally closed	RW	read/write
kOhm, kΩ	kilo-ohm	NEC	National Electrical Code	SAE	Society of Automotive Engineers
kPa	kilopascal	NEMA	National Electrical Manufacturers Association	scfm	standard cubic feet per minute
kph	kilometers per hour	NFPA	National Fire Protection Association	SCR	silicon controlled rectifier
kV	kilovolt	Nm	newton meter	s, sec.	second
kVA	kilovolt ampere	NO	normally open	SI	<i>Systeme international d'unites</i> , International System of Units
kVAR	kilovolt ampere reactive	no., nos.	number, numbers	SI/EO	side in/end out
kW	kilowatt	NPS	National Pipe, Straight	sil.	silencer
kWh	kilowatt-hour	NPSC	National Pipe, Straight-coupling	SN	serial number
kWm	kilowatt mechanical	NPT	National Standard taper pipe thread per general use	SNMP	simple network management protocol
kWth	kilowatt-thermal	NPTF	National Pipe, Taper-Fine	SPDT	single-pole, double-throw
L	liter	NR	not required, normal relay	SPST	single-pole, single-throw
LAN	local area network	ns	nanosecond	spec	specification
L x W x H	length by width by height	OC	overcrank	specs	specification(s)
lb.	pound, pounds	OD	outside diameter	sq.	square
lbm/ft ³	pounds mass per cubic feet	OEM	original equipment manufacturer	sq. cm	square centimeter
LCB	line circuit breaker	OF	overfrequency	sq. in.	square inch
LCD	liquid crystal display	opt.	option, optional	SS	stainless steel
ld. shd.	load shed	OS	oversize, overspeed	std.	standard
LED	light emitting diode	OSHA	Occupational Safety and Health Administration	stl.	steel
Lph	liters per hour	OV	overvoltage	tach.	tachometer
Lpm	liters per minute	oz.	ounce	TD	time delay
LOP	low oil pressure	p., pp.	page, pages	TDC	top dead center
LP	liquefied petroleum	PC	personal computer	TDEC	time delay engine cooldown
LPG	liquefied petroleum gas	PCB	printed circuit board	TDEN	time delay emergency to normal
LS	left side	pF	picofarad	TDES	time delay engine start
L _{wa}	sound power level, A weighted	PF	power factor	TDNE	time delay normal to emergency
LWL	low water level	ph., ∅	phase	TDOE	time delay off to emergency
LWT	low water temperature	PHC	Phillips® head Crimptite® (screw)	TDON	time delay off to normal
m	meter, milli (1/1000)	PHH	Phillips® hex head (screw)	temp.	temperature
M	mega (10 ⁶ when used with SI units), male	PHM	pan head machine (screw)	term.	terminal
m ³	cubic meter	PLC	programmable logic control	THD	total harmonic distortion
m ³ /hr.	cubic meters per hour	PMG	permanent magnet generator	TIF	telephone influence factor
m ³ /min.	cubic meters per minute	pot	potentiometer, potential	TIR	total indicator reading
mA	milliampere	ppm	parts per million	tol.	tolerance
man.	manual	PROM	programmable read-only memory	turbo.	turbocharger
max.	maximum	psi	pounds per square inch	typ.	typical (same in multiple locations)
MB	megabyte (2 ²⁰ bytes)	psig	pounds per square inch gauge	UF	underfrequency
MCCB	molded-case circuit breaker	pt.	pint	UHF	ultrahigh frequency
MCM	one thousand circular mils	PTC	positive temperature coefficient	UL	Underwriter's Laboratories, Inc.
meggar	megohmmeter	PTO	power takeoff	UNC	unified coarse thread (was NC)
MHz	megahertz	PVC	polyvinyl chloride	UNF	unified fine thread (was NF)
mi.	mile	qt.	quart, quarts	univ.	universal
mil	one one-thousandth of an inch	qty.	quantity	US	undersize, underspeed
min.	minimum, minute	R	replacement (emergency) power source	UV	ultraviolet, undervoltage
misc.	miscellaneous	rad.	radiator, radius	V	volt
MJ	megajoule	RAM	random access memory	VAC	volts alternating current
mJ	millijoule	RDO	relay driver output	VAR	voltampere reactive
mm	millimeter	ref.	reference	VDC	volts direct current
mOhm, mΩ	milliohm	rem.	remote	VFD	vacuum fluorescent display
MOhm, MΩ	megohm	Res/Coml	Residential/Commercial	VGA	video graphics adapter
MOV	metal oxide varistor	RFI	radio frequency interference	VHF	very high frequency
MPa	megapascal	RH	round head	W	watt
mph	miles per hour	RHM	round head machine (screw)	WCR	withstand and closing rating
MS	military standard	rly.	relay	w/	with
ms	millisecond	rms	root mean square	w/o	without
m/sec.	meters per second			wt.	weight
MTBF	mean time between failure			xfrm	transformer
MTBO	mean time between overhauls				
mtg.	mounting				
MTU	Motoren-und Turbinen-Union				

Appendix B Common Hardware Application Guidelines

Use the information below and on the following pages to identify proper fastening techniques when no specific reference for reassembly is made.

Bolt/Screw Length: When bolt/screw length is not given, use Figure 1 as a guide. As a general rule, a minimum length of one thread beyond the nut and a maximum length of 1/2 the bolt/screw diameter beyond the nut is the preferred method.

Washers and Nuts: Use split lock washers as a bolt locking device where specified. Use SAE flat washers with whiz nuts, spirallock nuts, or standard nuts and preloading (torque) of the bolt in all other applications.

See Appendix C, General Torque Specifications, and other torque specifications in the service literature.

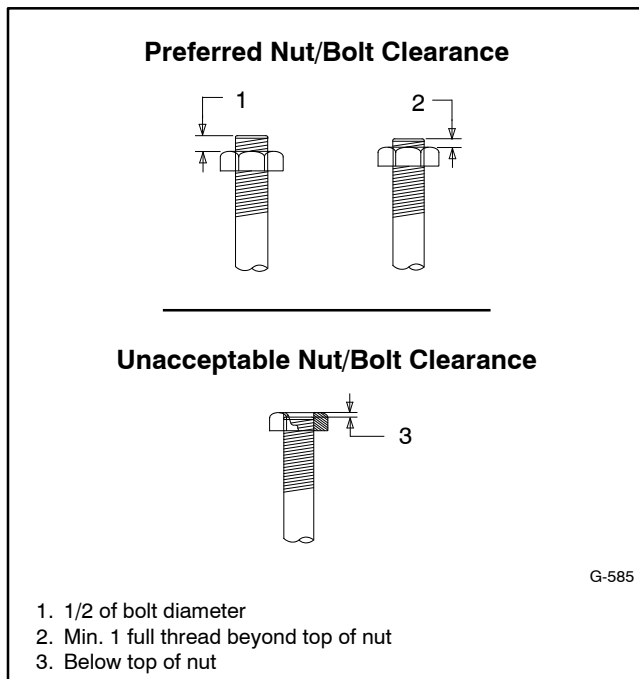

Figure 1 Acceptable Bolt Lengths

Steps for common hardware application:

1. Determine entry hole type: round or slotted.
2. Determine exit hole type: fixed female thread (weld nut), round, or slotted.

For round and slotted exit holes, determine if hardware is greater than 1/2 inch in diameter, or 1/2 inch in diameter or less. Hardware that is *greater than 1/2 inch* in diameter takes a standard nut and SAE washer. Hardware *1/2 inch or less* in diameter can take a properly torqued whiz nut or spirallock nut. See Figure 2.

3. Follow these SAE washer rules after determining exit hole type:
 - a. Always use a washer between hardware and a slot.
 - b. Always use a washer under a nut (see 2 above for exception).
 - c. Use a washer under a bolt when the female thread is fixed (weld nut).
4. Refer to Figure 2, which depicts the preceding hardware configuration possibilities.

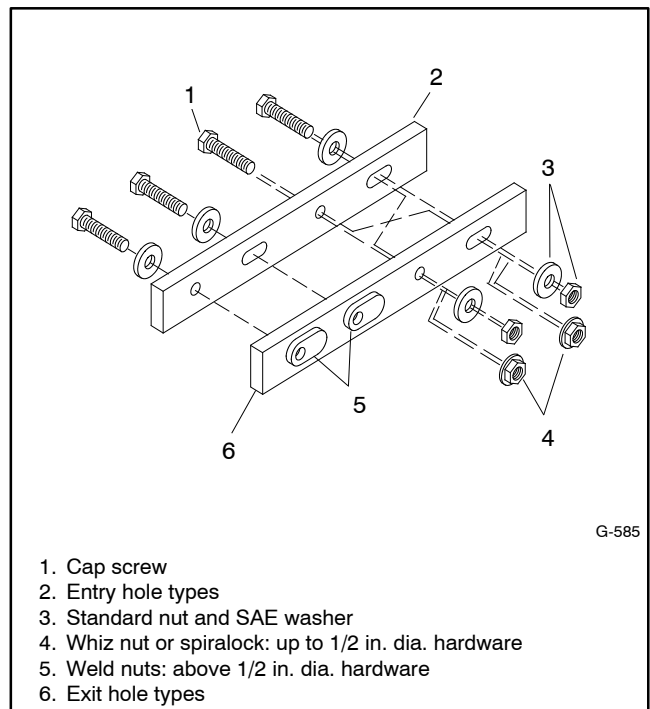

Figure 2 Acceptable Hardware Combinations

Appendix C General Torque Specifications















American Standard Fasteners Torque Specifications					
Size	Torque Measurement	Assembled into Cast Iron or Steel			Assembled into Aluminum Grade 2 or 5
		Grade 2	Grade 5	Grade 8	
8-32	Nm (in. lb.)	1.8 (16)	2.3 (20)	—	See Note 3
10-24	Nm (in. lb.)	2.9 (26)	3.6 (32)	—	
10-32	Nm (in. lb.)	2.9 (26)	3.6 (32)	—	
1/4-20	Nm (in. lb.)	6.8 (60)	10.8 (96)	14.9 (132)	
1/4-28	Nm (in. lb.)	8.1 (72)	12.2 (108)	16.3 (144)	
5/16-18	Nm (in. lb.)	13.6 (120)	21.7 (192)	29.8 (264)	
5/16-24	Nm (in. lb.)	14.9 (132)	23.1 (204)	32.5 (288)	
3/8-16	Nm (ft. lb.)	24.0 (18)	38.0 (28)	53.0 (39)	
3/8-24	Nm (ft. lb.)	27.0 (20)	42.0 (31)	60.0 (44)	
7/16-14	Nm (ft. lb.)	39.0 (29)	60.0 (44)	85.0 (63)	
7/16-20	Nm (ft. lb.)	43.0 (32)	68.0 (50)	95.0 (70)	
1/2-13	Nm (ft. lb.)	60.0 (44)	92.0 (68)	130.0 (96)	
1/2-20	Nm (ft. lb.)	66.0 (49)	103.0 (76)	146.0 (108)	
9/16-12	Nm (ft. lb.)	81.0 (60)	133.0 (98)	187.0 (138)	
9/16-18	Nm (ft. lb.)	91.0 (67)	148.0 (109)	209.0 (154)	
5/8-11	Nm (ft. lb.)	113.0 (83)	183.0 (135)	259.0 (191)	
5/8-18	Nm (ft. lb.)	128.0 (94)	208.0 (153)	293.0 (216)	
3/4-10	Nm (ft. lb.)	199.0 (147)	325.0 (240)	458.0 (338)	
3/4-16	Nm (ft. lb.)	222.0 (164)	363.0 (268)	513.0 (378)	
1-8	Nm (ft. lb.)	259.0 (191)	721.0 (532)	1109.0 (818)	
1-12	Nm (ft. lb.)	283.0 (209)	789.0 (582)	1214.0 (895)	











Metric Fasteners Torque Specifications, Measured in Nm (ft. lb.)				
Size (mm)	Assembled into Cast Iron or Steel			Assembled into Aluminum Grade 5.8 or 8.8
	Grade 5.8	Grade 8.8	Grade 10.9	
M6 x 1.00	6.2 (4.6)	9.5 (7)	13.6 (10)	See Note 3
M8 x 1.25	15.0 (11)	23.0 (17)	33.0 (24)	
M8 x 1.00	16.0 (11)	24.0 (18)	34.0 (25)	
M10 x 1.50	30.0 (22)	45.0 (34)	65.0 (48)	
M10 x 1.25	31.0 (23)	47.0 (35)	68.0 (50)	
M12 x 1.75	53.0 (39)	80.0 (59)	115.0 (85)	
M12 x 1.50	56.0 (41)	85.0 (63)	122.0 (90)	
M14 x 2.00	83.0 (61)	126.0 (93)	180.0 (133)	
M14 x 1.50	87.0 (64)	133.0 (98)	190.0 (140)	
M16 x 2.00	127.0 (94)	194.0 (143)	278.0 (205)	
M16 x 1.50	132.0 (97)	201.0 (148)	287.0 (212)	
M18 x 2.50	179.0 (132)	273.0 (201)	390.0 (288)	
M18 x 1.50	189.0 (140)	289.0 (213)	413.0 (305)	





Notes:

1. The torque values above are general guidelines. Always use the torque values specified in the service manuals and/or assembly drawings when they differ from the above torque values.
2. The torque values above are based on new plated threads. Increase torque values by 15% if non-plated threads are used.
3. Hardware threaded into aluminum must have either two diameters of thread engagement or a 30% or more reduction in the torque to prevent stripped threads.
4. Torque values are calculated as equivalent stress loading on American hardware with an approximate preload of 90% of the yield strength and a friction coefficient of 0.125.

Appendix D Common Hardware Identification

Screw/Bolts/Studs	
Head Styles	
Hex Head or Machine Head	
Hex Head or Machine Head with Washer	
Flat Head (FHM)	
Round Head (RHM)	
Pan Head	
Hex Socket Head Cap or Allen™ Head Cap	
Hex Socket Head or Allen™ Head Shoulder Bolt	
Sheet Metal Screw	
Stud	
Drive Styles	
Hex	
Hex and Slotted	
Phillips®	
Slotted	
Hex Socket	

Nuts	
Nut Styles	
Hex Head	
Lock or Elastic	
Square	
Cap or Acorn	
Wing	
Washers	
Washer Styles	
Plain	
Split Lock or Spring	
Spring or Wave	
External Tooth Lock	
Internal Tooth Lock	
Internal-External Tooth Lock	

Hardness Grades	
American Standard	
Grade 2	
Grade 5	
Grade 8	
Grade 8/9 (Hex Socket Head)	
Metric	
Number stamped on hardware; 5.8 shown	

Allen™ head screw is a trademark of Holo-Krome Co.

Phillips® screw is a registered trademark of Phillips Screw Company.

Sample Dimensions

American Standard (Screws, Bolts, Studs, and Nuts)

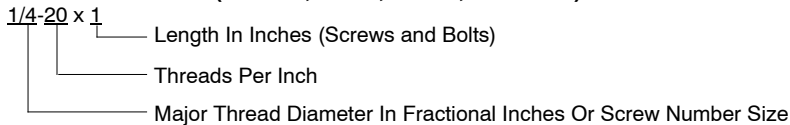

Metric (Screws, Bolts, Studs, and Nuts)

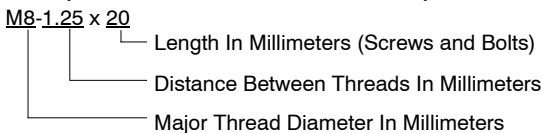

Plain Washers

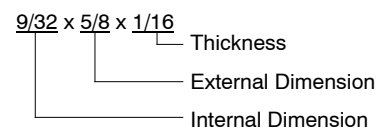

Lock Washers



Appendix E Common Hardware List

The Common Hardware List lists part numbers and dimensions for common hardware items.

American Standard

Part No.	Dimensions	Part No.	Dimensions	Part No.	Dimensions	Type
Hex Head Bolts (Grade 5)						
X-465-17	1/4-20 x .38	X-6238-14	3/8-24 x .75	X-6009-1	1-8	Standard
X-465-6	1/4-20 x .50	X-6238-16	3/8-24 x 1.25	X-6210-3	6-32	Whiz
X-465-2	1/4-20 x .62	X-6238-21	3/8-24 x 4.00	X-6210-4	8-32	Whiz
X-465-16	1/4-20 x .75	X-6238-22	3/8-24 x 4.50	X-6210-5	10-24	Whiz
X-465-18	1/4-20 x .88			X-6210-1	10-32	Whiz
X-465-7	1/4-20 x 1.00	X-6024-5	7/16-14 x .75			
X-465-8	1/4-20 x 1.25	X-6024-2	7/16-14 x 1.00	X-6210-2	1/4-20	Spiralock
X-465-9	1/4-20 x 1.50	X-6024-8	7/16-14 x 1.25	X-6210-6	1/4-28	Spiralock
X-465-10	1/4-20 x 1.75	X-6024-3	7/16-14 x 1.50	X-6210-7	5/16-18	Spiralock
X-465-11	1/4-20 x 2.00	X-6024-4	7/16-14 x 2.00	X-6210-8	5/16-24	Spiralock
X-465-12	1/4-20 x 2.25	X-6024-11	7/16-14 x 2.75	X-6210-9	3/8-16	Spiralock
X-465-14	1/4-20 x 2.75	X-6024-12	7/16-14 x 6.50	X-6210-10	3/8-24	Spiralock
X-465-21	1/4-20 x 5.00	X-129-15	1/2-13 x .75	X-6210-11	7/16-14	Spiralock
X-465-25	1/4-28 x .38	X-129-17	1/2-13 x 1.00	X-6210-12	1/2-13	Spiralock
X-465-20	1/4-28 x 1.00	X-129-18	1/2-13 x 1.25	X-6210-15	7/16-20	Spiralock
		X-129-19	1/2-13 x 1.50	X-6210-14	1/2-20	Spiralock
X-125-33	5/16-18 x .50	X-129-20	1/2-13 x 1.75			
X-125-23	5/16-18 x .62	X-129-21	1/2-13 x 2.00	X-85-3	5/8-11	Standard
X-125-3	5/16-18 x .75	X-129-22	1/2-13 x 2.25	X-88-12	3/4-10	Standard
X-125-31	5/16-18 x .88	X-129-23	1/2-13 x 2.50	X-89-2	1/2-20	Standard
X-125-5	5/16-18 x 1.00	X-129-24	1/2-13 x 2.75			
X-125-24	5/16-18 x 1.25	X-129-25	1/2-13 x 3.00			
X-125-34	5/16-18 x 1.50	X-129-27	1/2-13 x 3.50			
X-125-25	5/16-18 x 1.75	X-129-29	1/2-13 x 4.00			
X-125-26	5/16-18 x 2.00	X-129-30	1/2-13 x 4.50			
230578	5/16-18 x 2.25	X-463-9	1/2-13 x 5.50			
X-125-29	5/16-18 x 2.50	X-129-44	1/2-13 x 6.00			
X-125-27	5/16-18 x 2.75					
X-125-28	5/16-18 x 3.00	X-129-51	1/2-20 x .75			
X-125-22	5/16-18 x 4.50	X-129-45	1/2-20 x 1.25			
X-125-32	5/16-18 x 5.00	X-129-52	1/2-20 x 1.50			
X-125-35	5/16-18 x 5.50					
X-125-36	5/16-18 x 6.00	X-6021-3	5/8-11 x 1.00			
X-125-40	5/16-18 x 6.50	X-6021-4	5/8-11 x 1.25			
		X-6021-2	5/8-11 x 1.50			
X-125-43	5/16-24 x 1.75	X-6021-1	5/8-11 x 1.75			
X-125-44	5/16-24 x 2.50	273049	5/8-11 x 2.00			
X-125-30	5/16-24 x .75	X-6021-5	5/8-11 x 2.25			
X-125-39	5/16-24 x 2.00	X-6021-6	5/8-11 x 2.50			
X-125-38	5/16-24 x 2.75	X-6021-7	5/8-11 x 2.75			
		X-6021-12	5/8-11 x 3.75			
X-6238-2	3/8-16 x .62	X-6021-11	5/8-11 x 4.50			
X-6238-10	3/8-16 x .75	X-6021-10	5/8-11 x 6.00			
X-6238-3	3/8-16 x .88					
X-6238-11	3/8-16 x 1.00	X-6021-9	5/8-18 x 2.50			
X-6238-4	3/8-16 x 1.25					
X-6238-5	3/8-16 x 1.50	X-6239-1	3/4-10 x 1.00			
X-6238-1	3/8-16 x 1.75	X-6239-8	3/4-10 x 1.25			
X-6238-6	3/8-16 x 2.00	X-6239-2	3/4-10 x 1.50			
X-6238-17	3/8-16 x 2.25	X-6239-3	3/4-10 x 2.00			
X-6238-7	3/8-16 x 2.50	X-6239-4	3/4-10 x 2.50			
X-6238-8	3/8-16 x 2.75	X-6239-5	3/4-10 x 3.00			
X-6238-9	3/8-16 x 3.00	X-6239-6	3/4-10 x 3.50			
X-6238-19	3/8-16 x 3.25					
X-6238-12	3/8-16 x 3.50	X-792-1	1-8 x 2.25			
X-6238-20	3/8-16 x 3.75	X-792-5	1-8 x 3.00			
X-6238-13	3/8-16 x 4.50	X-792-8	1-8 x 5.00			
X-6238-18	3/8-16 x 5.50					
X-6238-25	3/8-16 x 6.50					

Washers				Bolt/ Screw
Part No.	ID	OD	Thick.	
X-25-46	.125	.250	.022	#4
X-25-9	.156	.375	.049	#6
X-25-48	.188	.438	.049	#8
X-25-36	.219	.500	.049	#10
X-25-40	.281	.625	.065	1/4
X-25-85	.344	.687	.065	5/16
X-25-37	.406	.812	.065	3/8
X-25-34	.469	.922	.065	7/16
X-25-26	.531	1.062	.095	1/2
X-25-15	.656	1.312	.095	5/8
X-25-29	.812	1.469	.134	3/4
X-25-127	1.062	2.000	.134	1

Metric

Hex head bolts are hardness grade 8.8 unless noted.

Part No.	Dimensions	Part No.	Dimensions	Part No.	Dimensions
Hex Head Bolts (Partial Thread)		Hex Head Bolts (Partial Thread), continued		Hex Head Bolts (Full Thread), continued	
M931-05055-60	M5-0.80 x 55	M960-16090-60	M16-1.50 x 90	M933-12016-60	M12-1.75 x 16
M931-06040-60	M6-1.00 x 40	M931-16090-60	M16-2.00 x 90	M933-12020-60	M12-1.75 x 20
M931-06055-60	M6-1.00 x 55	M931-16100-60	M16-2.00 x 100	M961-12020-60F	M12-1.50 x 20
M931-06060-60	M6-1.00 x 60	M931-16100-82	M16-2.00 x 100*	M933-12025-60	M12-1.75 x 25
M931-06060-SS	M6-1.00 x 60	M931-16120-60	M16-2.00 x 120	M933-12025-82	M12-1.75 x 25*
M931-06070-60	M6-1.00 x 70	M931-16150-60	M16-2.00 x 150	M961-12030-60	M12-1.25 x 30
M931-06070-SS	M6-1.00 x 70			M933-12030-82	M12-1.75 x 30*
M931-06075-60	M6-1.00 x 75	M931-20065-60	M20-2.50 x 65	M961-12030-82F	M12-1.50 x 30*
M931-06090-60	M6-1.00 x 90	M931-20090-60	M20-2.50 x 90	M933-12030-60	M12-1.75 x 30
M931-06145-60	M6-1.00 x 145	M931-20100-60	M20-2.50 x 100	M933-12035-60	M12-1.75 x 35
M931-06150-60	M6-1.00 x 150	M931-20120-60	M20-2.50 x 120	M961-12040-82	M12-1.25 x 40*
		M931-20140-60	M20-2.50 x 140	M933-12040-60	M12-1.75 x 40
M931-08035-60	M8-1.25 x 35	M931-20160-60	M20-2.50 x 160	M933-12040-82	M12-1.75 x 40*
M931-08040-60	M8-1.25 x 40				
M931-08045-60	M8-1.25 x 45	M931-22090-60	M22-2.50 x 90	M961-14025-60	M14-1.50 x 25
M931-08050-60	M8-1.25 x 50	M931-22120-60	M22-2.50 x 120	M933-14025-60	M14-2.00 x 25
M931-08055-60	M8-1.25 x 55	M931-22160-60	M22-2.50 x 160	M961-14050-82	M14-1.50 x 50*
M931-08055-82	M8-1.25 x 55*				
M931-08060-60	M8-1.25 x 60	M931-24090-60	M24-3.00 x 90	M961-16025-60	M16-1.50 x 25
M931-08070-60	M8-1.25 x 70	M931-24120-60	M24-3.00 x 120	M933-16025-60	M16-2.00 x 25
M931-08070-82	M8-1.25 x 70*	M931-24160-60	M24-3.00 x 160	M961-16030-82	M16-1.50 x 30*
M931-08075-60	M8-1.25 x 75	M931-24200-60	M24-3.00 x 200	M933-16030-82	M16-2.00 x 30*
M931-08080-60	M8-1.25 x 80			M933-16035-60	M16-2.00 x 35
M931-08090-60	M8-1.25 x 90	Hex Head Bolts (Full Thread)		M961-16040-60	M16-1.50 x 40
M931-08095-60	M8-1.25 x 95	M933-04006-60	M4-0.70 x 6	M933-16040-60	M16-2.00 x 40
M931-08100-60	M8-1.25 x 100			M961-16045-82	M16-1.50 x 45*
M931-08110-60	M8-1.25 x 110	M933-05030-60	M5-0.80 x 30	M933-16045-82	M16-2.00 x 45*
M931-08120-60	M8-1.25 x 120	M933-05035-60	M5-0.80 x 35	M933-16050-60	M16-2.00 x 50
M931-08130-60	M8-1.25 x 130	M933-05050-60	M5-0.80 x 50	M933-16050-82	M16-2.00 x 50*
M931-08140-60	M8-1.25 x 140			M933-16060-60	M16-2.00 x 60
M931-08150-60	M8-1.25 x 150			M933-16070-60	M16-2.00 x 70
M931-08200-60	M8-1.25 x 200				
				M933-18035-60	M18-2.50 x 35
M931-10040-82	M10-1.25 x 40*			M933-18050-60	M18-2.50 x 50
M931-10040-60	M10-1.50 x 40			M933-18060-60	M18-2.50 x 60
M931-10045-60	M10-1.50 x 45				
M931-10050-60	M10-1.50 x 50			M933-20050-60	M20-2.50 x 50
M931-10050-82	M10-1.25 x 50*			M933-20055-60	M20-2.50 x 55
M931-10055-60	M10-1.50 x 55				
M931-10060-60	M10-1.50 x 60			M933-24060-60	M24-3.00 x 60
M931-10065-60	M10-1.50 x 65			M933-24065-60	M24-3.00 x 65
M931-10070-60	M10-1.50 x 70	M933-07025-60	M7-1.00 x 25	M933-24070-60	M24-3.00 x 70
M931-10080-60	M10-1.50 x 80				
M931-10080-82	M10-1.25 x 80*	M933-08010-60	M8-1.25 x 10	Pan Head Machine Screws	
M931-10090-60	M10-1.50 x 90	M933-08012-60	M8-1.25 x 12	M7985A-03010-20	M3-0.50 x 10
M931-10090-82	M10-1.50 x 90*	M933-08016-60	M8-1.25 x 16	M7985A-03012-20	M3-0.50 x 12
M931-10100-60	M10-1.50 x 100	M933-08020-60	M8-1.25 x 20		
M931-10110-60	M10-1.50 x 110	M933-08025-60	M8-1.25 x 25	M7985A-04010-20	M4-0.70 x 10
M931-10120-60	M10-1.50 x 120	M933-08030-60	M8-1.25 x 30	M7985A-04016-20	M4-0.70 x 16
M931-10130-60	M10-1.50 x 130	M933-08030-82	M8-1.25 x 30*	M7985A-04020-20	M4-0.70 x 20
M931-10140-60	M10-1.50 x 140			M7985A-04050-20	M4-0.70 x 50
M931-10180-60	M10-1.50 x 180	M933-10012-60	M10-1.50 x 12	M7985A-04100-20	M4-0.70 x 100
M931-10235-60	M10-1.50 x 235	M961-10020-60	M10-1.25 x 20		
M931-10260-60	M10-1.50 x 260	M933-10020-60	M10-1.50 x 20	M7985A-05010-20	M5-0.80 x 10
M960-10330-60	M10-1.25 x 330	M933-10025-60	M10-1.50 x 25	M7985A-05012-20	M5-0.80 x 12
		M961-10025-60	M10-1.25 x 25	M7985A-05016-20	M5-0.80 x 16
M931-12045-60	M12-1.75 x 45	M933-10025-82	M10-1.50 x 25*	M7985A-05020-20	M5-0.80 x 20
M960-12050-60	M12-1.25 x 50	M961-10030-60	M10-1.25 x 30	M7985A-05025-20	M5-0.80 x 25
M960-12050-82	M12-1.25 x 50*	M933-10030-60	M10-1.50 x 30	M7985A-05030-20	M5-0.80 x 30
M931-12050-60	M12-1.75 x 50	M933-10030-82	M10-1.50 x 30*	M7985A-05080-20	M5-0.80 x 80
M931-12050-82	M12-1.75 x 50*	M961-10035-60	M10-1.25 x 35	M7985A-05100-20	M5-0.80 x 100
M931-12055-60	M12-1.75 x 55	M933-10035-60	M10-1.50 x 35		
M931-12060-60	M12-1.75 x 60	M933-10035-82	M10-1.50 x 35*	M7985A-06100-20	M6-1.00 x 100
M931-12060-82	M12-1.75 x 60*	M961-10040-60	M10-1.25 x 40		
M931-12065-60	M12-1.75 x 65			Flat Head Machine Screws	
M931-12075-60	M12-1.75 x 75			M965A-04012-SS	M4-0.70 x 12
M931-12080-60	M12-1.75 x 80				
M931-12090-60	M12-1.75 x 90			M965A-05012-SS	M5-0.80 x 12
M931-12100-60	M12-1.75 x 100			M965A-05016-20	M5-0.80 x 16
M931-12110-60	M12-1.75 x 110			M965A-06012-20	M6-1.00 x 12

* This metric hex bolt's hardness is grade 10.9.

Metric, continued

Part No.	Dimensions	Type
Hex Nuts		
M934-03-50	M3-0.50	Standard
M934-04-50	M4-0.70	Standard
M934-04-B	M4-0.70	Brass
M934-05-50	M5-0.80	Standard
M934-06-60	M6-1.00	Standard
M934-06-64	M6-1.00	Std. (green)
M6923-06-80	M6-1.00	Spirallock
M982-06-80	M6-1.00	Elastic Stop
M934-08-60	M8-1.25	Standard
M6923-08-80	M8-1.25	Spirallock
M982-08-80	M8-1.25	Elastic Stop
M934-10-60	M10-1.50	Standard
M934-10-60F	M10-1.25	Standard
M6923-10-80	M10-1.50	Spirallock
M6923-10-62	M10-1.50	Spirallock†
M982-10-80	M10-1.50	Elastic Stop
M934-12-60	M12-1.75	Standard
M934-12-60F	M12-1.25	Standard
M6923-12-80	M12-1.75	Spirallock
M982-12-80	M12-1.75	Elastic Stop
M982-14-60	M14-2.00	Elastic Stop
M6923-16-80	M16-2.00	Spirallock
M982-16-80	M16-2.00	Elastic Stop
M934-18-80	M18-2.5	Standard
M982-18-60	M18-2.50	Elastic Stop
M934-20-80	M20-2.50	Standard
M982-20-80	M20-2.50	Elastic Stop
M934-22-60	M22-2.50	Standard
M934-24-80	M24-3.00	Standard
M982-24-60	M24-3.00	Elastic Stop
M934-30-80	M30-3.50	Standard

Washers

Part No.	ID	OD	Thick.	Bolt/ Screw
M125A-03-80	3.2	7.0	0.5	M3
M125A-04-80	4.3	9.0	0.8	M4
M125A-05-80	5.3	10.0	1.0	M5
M125A-06-80	6.4	12.0	1.6	M6
M125A-08-80	8.4	16.0	1.6	M8
M125A-10-80	10.5	20.0	2.0	M10
M125A-12-80	13.0	24.0	2.5	M12
M125A-14-80	15.0	28.0	2.5	M14
M125A-16-80	17.0	30.0	3.0	M16
M125A-18-80	19.0	34.0	3.0	M18
M125A-20-80	21.0	37.0	3.0	M20
M125A-24-80	25.0	44.0	4.0	M24

† This metric hex nut's hardness is grade 8.

KOHLER[®] Power Systems

KOHLER CO. Kohler, Wisconsin 53044
Phone 920-457-4441, Fax 920-459-1646

Kohler Power Systems
Asia Pacific Headquarters
7 Jurong Pier Road
Singapore 619159
Phone (65) 6264-6422, Fax (65) 6264-6455

**For the nearest KOHLER authorized
installation, service, and sales dealer in
the US and Canada:
Call 1-800-544-2444 or visit
KOHLERPower.com**

TP-5868 8/15m

© 2004, 2008, 2009, 2011, 2012, 2015 by Kohler Co. All rights reserved.