

Service Parts

Residential/Commercial Generator Sets



Model:

24RCL
30RCL
38RCLB

See Group 701: Literature, inside this manual for
part number of the engine parts catalog

KOHLER
Power Systems

9001
KOHLER
POWER SYSTEMS
NATIONALLY REGISTERED

TP-6908 4/16b

Table of Contents

Introduction	4
Numbering System Significance	4
Illustrations	4
How to Find Part Numbers	4
Hardware References	4
Specification Number Index	5
Air Intake	6
Cooling System	10
Engine	16
Nameplate and Decals	20
Skid and Mounting	21
Alternator and Mounting	22
Alternator Modules GM87474-	22
Alternator Modules GM97041-	26
Control and Harness	28
Circuit Breaker and Mounting	32
Sound Shield Enclosure	34
Sound Shield Modules GM91044-	34
Sound Shield Modules GM97051-	35
Literature	36
Optional Kits	37
Appendix A Abbreviations	39
Appendix B Common Hardware Application Guidelines	41
Appendix C General Torque Specifications	42
Appendix D Common Hardware Identification	43
Appendix E Common Hardware List	44
Index	47

Introduction

This manual lists service replacement parts for Kohler Power Systems generator sets. See front cover for list of models.

Information in this publication represents data available at the time of print. Kohler Co. reserves the right to change this publication and the products represented without notice and without any obligation or liability whatsoever.

This manual includes the following main sections:

Table of Contents. Lists the sections of the manual.

Introduction (and other information sections). Contains introductory material about part numbers, illustrations, and hardware.

Specification Number Index. Lists the generator set specs and groups.

Group Parts Lists. List the part numbers of parts in the groups.

Kit Sections. List modules and accessories and their parts.

Appendices. Include Abbreviations, Common Hardware Application Guidelines, General Torque Specifications, Common Hardware Identification, and Common Hardware List.

Numbering System Significance

This manual uses the following numbering systems:

Specification Number. The product identification number located on the generator set nameplate. Specification numbers break down into groups.

Group Number. A unique number representing a parts group needed to assemble a generator set function. For example, Group 101 is the Air Intake group.

Variation or Module Number. A group might have several variations. Each variation performs the same function with different parts lists. For example, a 50 Hz generator alternator and a 60 Hz generator alternator both perform the same function; however, with different parts. Each difference requires a group variation or module number.

Part Number. The part number identifies an individual assembly, subassembly, component, or accessory kit.

Illustrations

Illustrations (or exploded-view drawings) best representing the widest range of variations accompany most groups in this manual. Illustrations do not depict all details and may not show all parts. Do not use illustrations for assembly or disassembly.

How to Find Part Numbers

Use the following steps to locate a service replacement part.

1. Locate the generator set nameplate to **identify the generator set spec number**.
2. Locate a second generator set nameplate listing accessories to **identify installed modules**. On some models the accessory nameplate is mounted inside the generator junction box.
3. **Turn to the Specification Number Index**. The first column lists the generator set spec numbers. The headings identify the groups of parts that make up the generator set.
4. **Identify the group** most likely to include the service part number.
5. **Find the group variation number** at the intersection of the spec number row and the group column. Note the variation number.
6. **Page forward to locate the group** identified in step 4 or find the appropriate page in the Table of Contents.
7. **Find the part on the illustration** and note the item number of the part or **find the part description in the parts list**.
8. Select **the part number that corresponds to your group variation**. The first column lists the illustration item number. Find the variation identified in the Specification Number Index or the module number found on the generator set nameplate in the appropriate column on the right side of the parts list table. Find the quantity used at the intersection of the item number row and the variation column. A blank space at the intersection means the variation/module does not use that part number.

Hardware References

Many common hardware items do not appear in parts manuals or will appear as common hardware entries. A common hardware entry lists the size of the hardware. For example, an item that appears as "Hardware, 3/8-16" in the text means that the piece is 3/8-16 size. Obtain common hardware locally or, if contacting the factory, use the Common Hardware List in the appendix to identify the common hardware part number and specifications. See Common Hardware Application Guidelines in the appendix for mating hardware instructions.

Some hardware items require a specific size or some other characteristic. In that case, use the part number listed in the text.

When replacing hardware, do not substitute inferior grade hardware. Replacement hardware grade should be equal to or better than the grade of the manufacturer's original hardware. Use the Common Hardware List in the appendix to identify the common hardware hardness.

Specification Number Index

	Variation	
	Model/Specification number	
	24RCL	
Group Description	GM92044-GA1	GM92044-GA2
Air Intake	GM90232-GR1	GM90232-GR2
Cooling System	GM90230-GR1	GM92075-GR2
Engine	GM90228-GR1	GM90228-GR1
Nameplate and Decals	GM78523-GR1	GM78523-GR1
Skid and Plant Mounting	GM91038-GR1	GM91038-GR1
Alternator and Mounting	*	*
Control and Harness	GM91287-GR1	GM91287-GR1
Circuit Breaker and Mounting	*	*
Sound Shield Enclosure	*	*
Literature	701-184-527	701-184-527

	Variation	
	Model/Specification number	
	30RCL	38RCLB
Group Description	GM97320-GA1	GM99405-GA1
Air Intake	GM92369-GR1	GM92369-GR1
Cooling System	GM92075-GR1	GM92075-GR1
Engine	GM92074-GR1	GM92074-GR1
Nameplate and Decals	GM78523-GR1	GM78523-GR1
Skid and Plant Mounting	GM91038-GR1	GM91038-GR1
Alternator and Mounting	*	*
Control and Harness	GM91287-GR4	GM91287-GR4
Circuit Breaker and Mounting	*	*
Sound Shield Enclosure	*	*
Literature	701-184-530	701-184-531

* Configured group. Refer to the generator set nameplate for the module number.
Turn to the respective group on the following pages for parts breakdowns.

Air Intake

GM90232-GR1

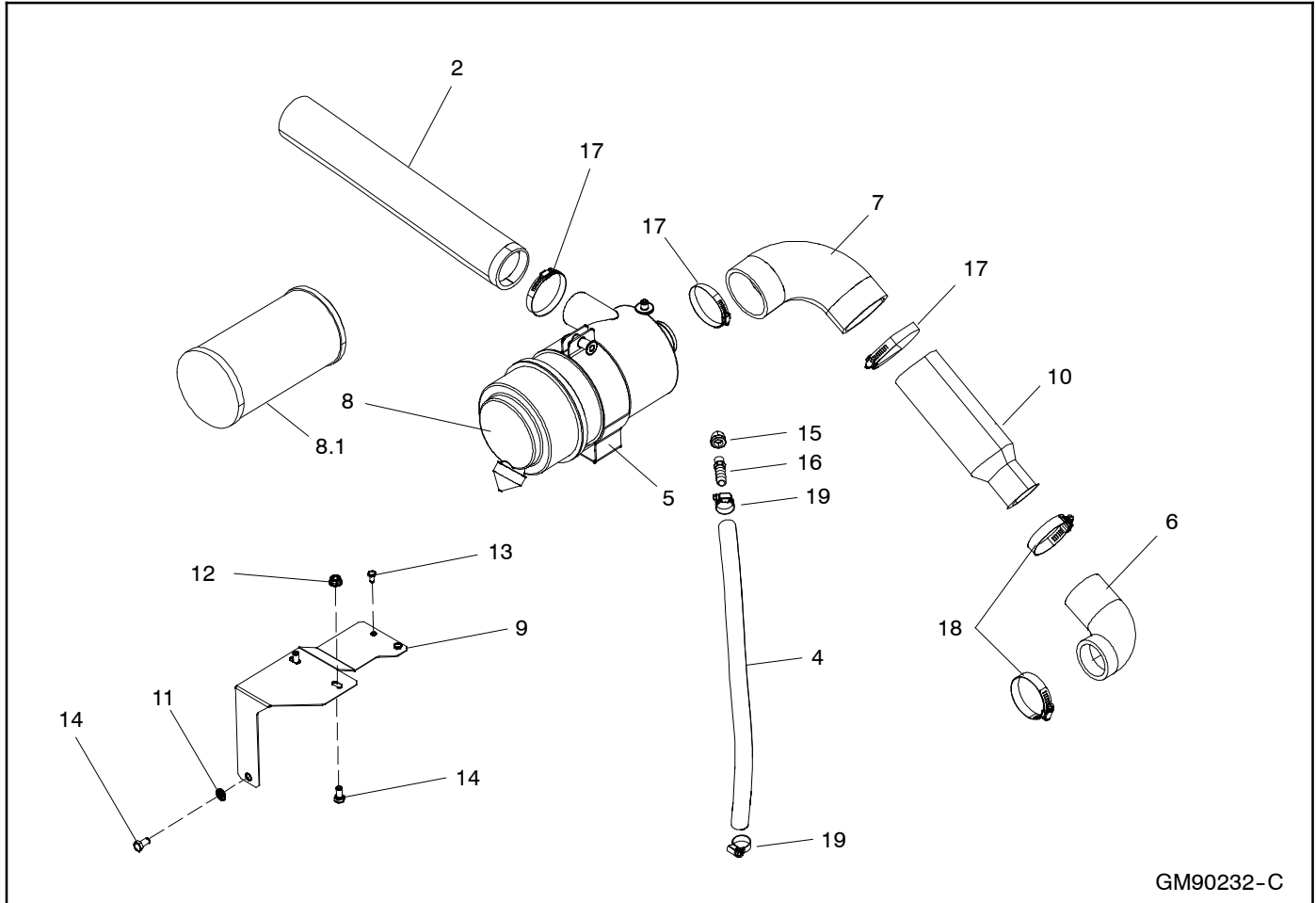

GM90232-C

Item	Part Number	Description	Quantity
			ModuleNumber GM90232-GR1
2	X-507-13	Hose, Radiator, Straight, 3 in. ID	1
4	X-386-141	Line, Flex	1
5	GM14200	Mount, air cleaner (6.76" id)	1
6	GM32869	Hose, 90 Deg. Elbow	1
7	GM89895	Hose, 90 Deg. Elbow	1
8	GM90280	Air Cleaner Assy	1
8.1	GM90281	Element, Air Cleaner	1
9	GM91330	Bracket, Air Intake	1
10	GM93779	Reducer, Hose	1
11	M125A-08-80	Washer, Plain 8.4 ID x 16.0 OD	1
12	M6923-08-80	Nut, Hex 8mm	2
13	M933-06010-60	Screw, Hex Cap	2
14	M933-08016-60	Screw, Hex Cap	3
15	X-215-19	Elbow, pipe (90 deg x 1/8" npt)	1
16	X-380-3	Connector, hose + Vibra Seal	1
17	X-426-1	Clamp, hose, 2.81/3.75 in.	3
18	X-426-2	Clamp, hose, 2.31/3.25 in.	2
19	X-426-9	Clamp, hose, .25/.70 in.	2

Air Intake

GM90232-GR2

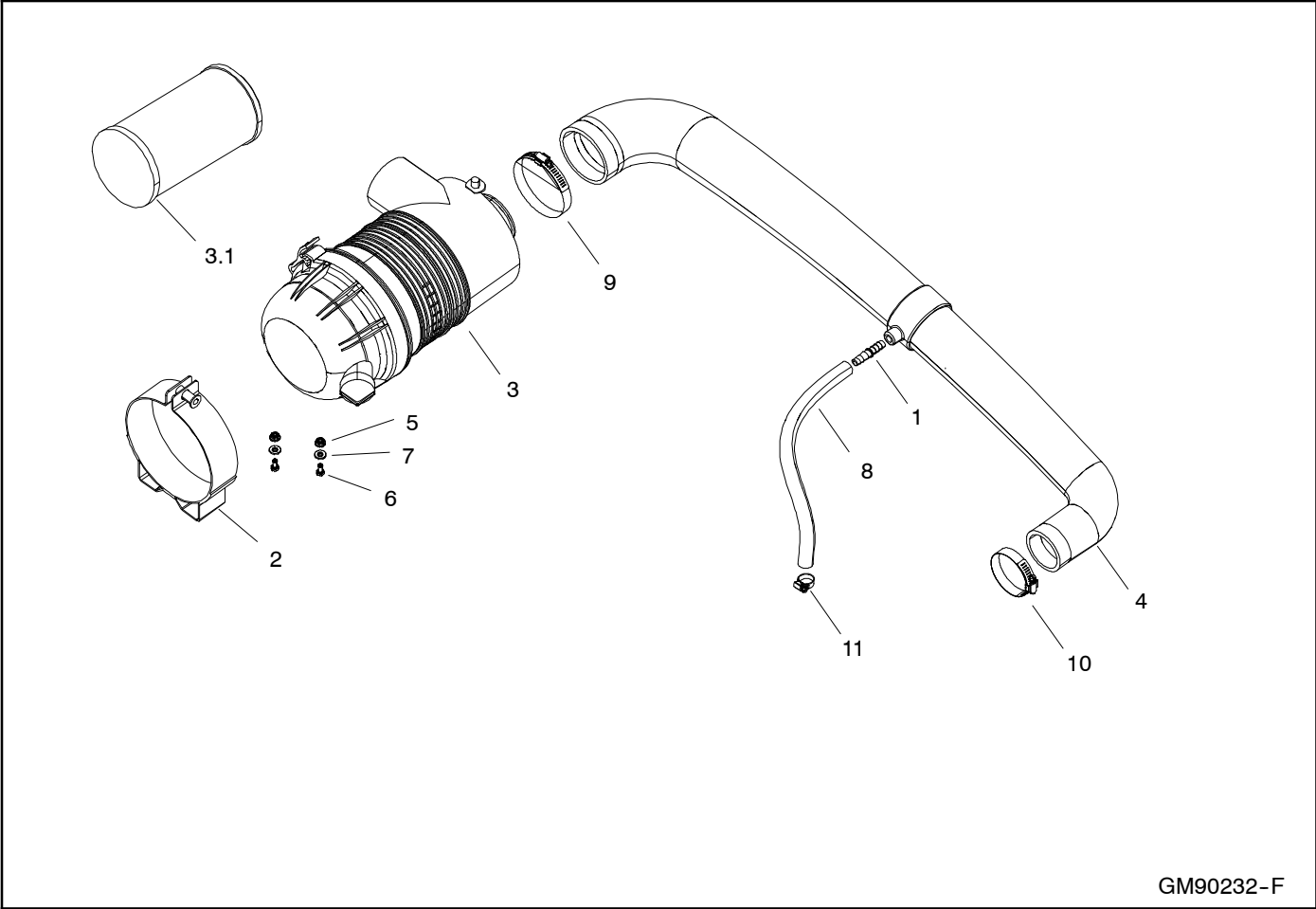

GM90232-F

Item	Part Number	Description	Quantity
			ModuleNumber GM90232-GR2
1	344754	Connector, hose	1
2	GM14200	Mount, Air Cleaner (6.76"ID)	1
3	GM90280	Air Cleaner Assy	1
3.1	GM90281	Element, Air Cleaner	1
4	GM95583	Hose, Air Intake	1
5	M6923-08-80	Nut, Hex 8MM	2
6	M933-08012-60	Screw	2
7	X-25-40	Washer, Plain, .281 ID X .625 in. OD	2
8	X-386-141	Line, Flex	1
9	X-426-1	Clamp, hose, 2.81/3.75 in.	1
10	X-426-2	Clamp, hose, 2.31/3.25 in.	1
11	X-426-9	Clamp, hose, .25/.70 in.	1

Air Intake, continued

GM92369-GR1

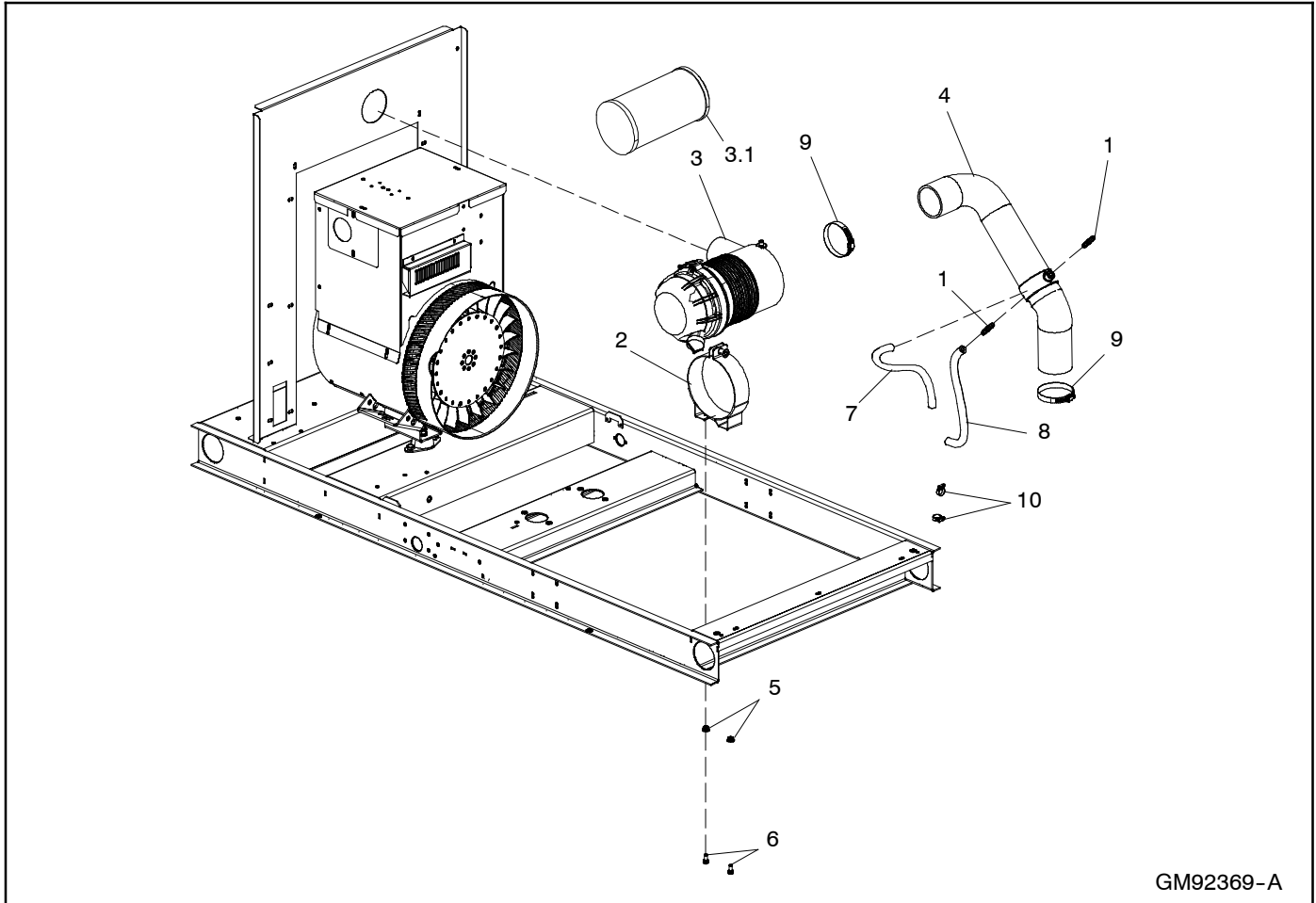

GM92369-A

Item	Part Number	Description	Quantity	
			ModuleNumber	GM92369-GR1
1	344754	Connector, hose	2	
2	GM14200	Mount, air cleaner (6.76" id)	1	
3	GM90280	Air Cleaner Assy.	1	
3.1	GM90281	Element, Air Cleaner	1	
4	GM92385	Hose, Air Intake	1	
5	M6923-08-80	Nut, Hex 8mm	2	
6	M933-08016-60	Screw, Hex Cap	2	
7	X-386-109	Fuel line, flexible	1	
8	X-386-141	Line, Flex Fuel	1	
9	X-426-1	Clamp, hose, 2.81/3.75 in.	2	
10	X-426-9	Clamp, hose, .25/.70 in.	2	

Notes

Cooling System

GM90230-GR1

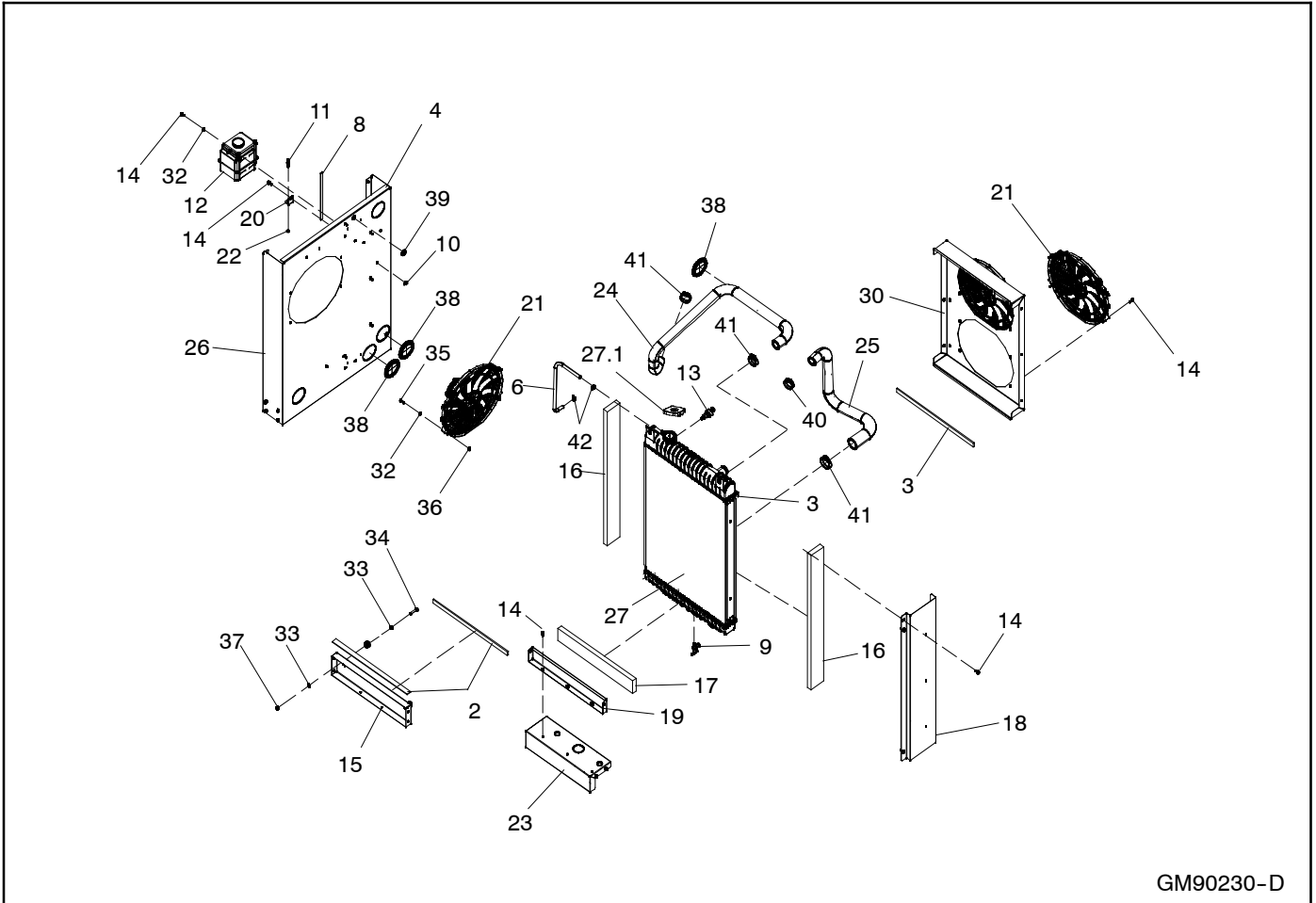

GM90230-D

Cooling System

GM90230-GR1

Item	Part Number	Description	Quantity
2	19010 08118	Neoprene, closed cell (1"W x 1/4"T)	2
3	19010 08118	Neoprene, closed cell (1"W x 1/4"T)	2
4	19010 08118	Neoprene, closed cell (1"W x 1/4"T)	1
6	X-386-142	Line, Flex Fuel	1
8	X-6047-31	Channel, U	1
9	278788	Valve, drain (3/8"nptf)	1
10	361567	Base, tie wrap snapin	2
11	GM28823	Sensor, Temperature	1
12	GM47692	Bottle, Overflow	1
13	GM66270	Sensor, Low Coolant Level	1
14	GM78761-1	Screw, Sheetmetal	37
15	GM82973	Mount, Radiator Upper	1
16	GM82979-1	Insulation, Acoustic	2
17	GM82979-2	Insulation, Acoustic	1
18	GM83755	Shroud, Radiator Front	1
19	GM83762	Bracket, Lower Radiator	1
20	GM83899	Bracket, Temperature Sender	1
21	GM83900	Fan Assembly	3
22	GM84247	Nut, 1/8-27 NPT	1
23	GM85643	Mount, Radiator Lower	1
24	GM90237	Hose, Upper Radiator	1
25	GM90238	Hose, Lower Radiator	1
26	GM91063	Panel, Bulkhead	1
27	GM79552	Radiator	1
27.1	GM88429	Radiator Cap	1
30	GM91554	Shroud, Radiator	1
32	M125A-06-80	Washer, Plain	6
33	M125A-08-80	Washer, Plain 8.4 ID x 16.0 OD	4
34	M931-08040-60	Screw, Hex Cap	2
35	M933-06020-60	Screw, Hex Cap	4
36	M982-06-80	Nut, hex elastic stop, 6MM	4
37	M982-08-80	Nut, hex elastic stop, 8MM	2
38	X-284-31	Grommet, round	3
39	X-284-7	Grommet, round	1
40	X-426-19	Clamp, hose, 1.00/2.00 in.	1
41	X-426-16	Clamp, hose, 1.81/2.75 in.	3
42	X-426-9	Clamp, hose, .25/.70 in.	2

Cooling System, continued

GM92075-GR1

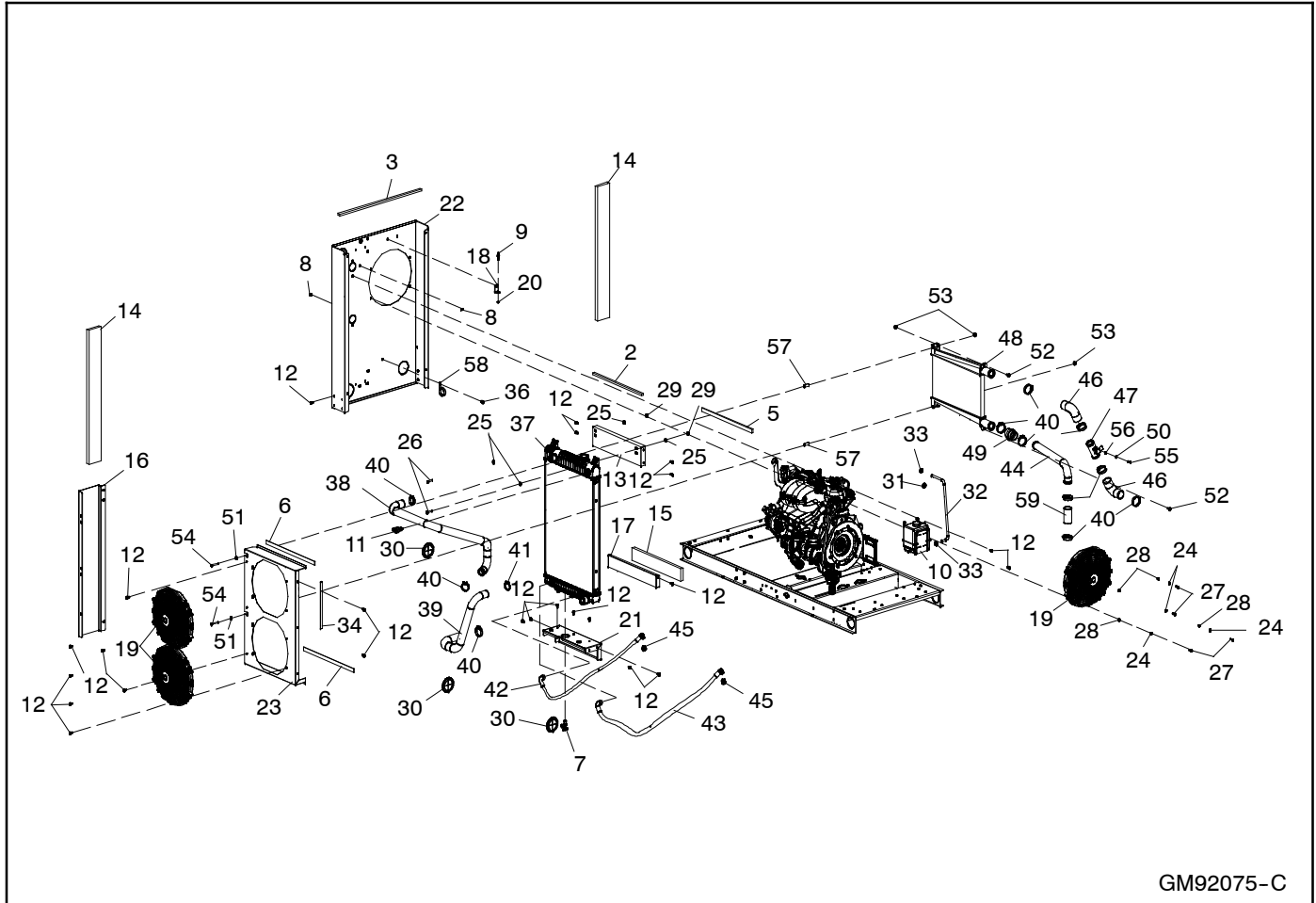

GM92075-C

Cooling System, continued

GM92075-GR1

Item	Part Number	Description	Quantity
2	19000 08075	Foam, gasket seal (3/4" tape) 530 mm	1
3	19000 08075	Foam, gasket seal (3/4" tape) 750 mm	1
5	19010 08118	Neoprene, closed cell (1"W x 1/4"T) 527 mm	1
6	19010 08118	Neoprene, closed cell (1"W x 1/4"T) 545 mm	2
7	278788	Valve, drain (3/8"nptf)	1
8	361567	Base, tie wrap snapin	2
9	GM28823	Sensor, Temperature	1
10	GM47692	Bottle, Overflow	1
11	GM66270	Sensor, Low Coolant Level	1
12	GM78761-1	Screw, Sheetmetal	37
13	GM82973	Mount, Radiator Upper	1
14	GM82979-1	Insulation, Acoustic	2
15	GM82979-2	Insulation, Acoustic	1
16	GM83755	Shroud, Radiator Front	1
17	GM83762	Bracket, Lower Radiator	1
18	GM83899	Bracket, Temperature Sender	1
19	GM83900	Fan Assembly	3
20	GM84247	Nut, 1/8-27 NPT	1
21	GM85643	Mount, Radiator Lower	1
22	GM91063	Panel, Bulkhead	1
23	GM91554	Shroud, Radiator	1
24	M125A-06-80	Washer, Plain	4
25	M125A-08-80	Washer, Plain 8.4 ID x 16.0 OD	4
26	M931-08040-60	Screw, Hex Cap	2
27	M933-06020-60	Screw, Hex Cap	4
28	M982-06-80	Nut, hex elastic stop, 6MM	4
29	M982-08-80	Nut, hex elastic stop, 8MM	2
30	X-284-31	Grommet, round	3
31	X-284-7	Grommet, round	1
32	X-386-142	Line, Flex Fuel	1
33	X-426-9	Clamp, hose, .25/.70 in.	2
34	X-6047-31	Channel, U	1
36	GM78761-1	Screw, Sheetmetal	1
37	GM91302	Radiator	1
38	GM90237	Hose, Upper Radiator	1
39	GM90238	Hose, Lower Radiator	1
40	X-426-16	Clamp, hose, 1.81/2.75 in.	11
41	X-426-19	Clamp, hose, 1.00/2.00 in.	1
42	GM91498	Hose, Oil Cooler Inlet	1
43	GM91499	Hose, Oil Cooler Outlet	1
44	GM92384	Tube, Turbo	1
45	GM93389	Adapter, JIC Reducer	2
46	GM95671	Hose, Charge Air Cooler	2
47	GM95687	Tube, CAC, With Port	1
48	GM95704	Radiator, Charge Air Cooler	1
49	GM97007	Hose, Hump (2.00" ID)	1
50	M125A-06-80	Washer, Plain	1
51	M125A-08-80	Washer, Plain 8.4 ID x 16.0 OD	2
52	M6921-08020-60	Screw, Hex Flange M8 x 20	2
53	M6923-08-80	Nut, Hex 8mm	4
54	M931-08055-60	Screw, Hex Cap	2
55	M933-06020-60	Screw, Hex Cap	1
56	X-20-1	Washer, lock, .259 ID x .489 in. OD	1
57	X-400-260	Spacer	2
58	X-672-40	Clamp, Insulated	1
59	X-6380-11	Hose, Charged Air Cooler	1

Cooling System, continued

GM92075-GR2

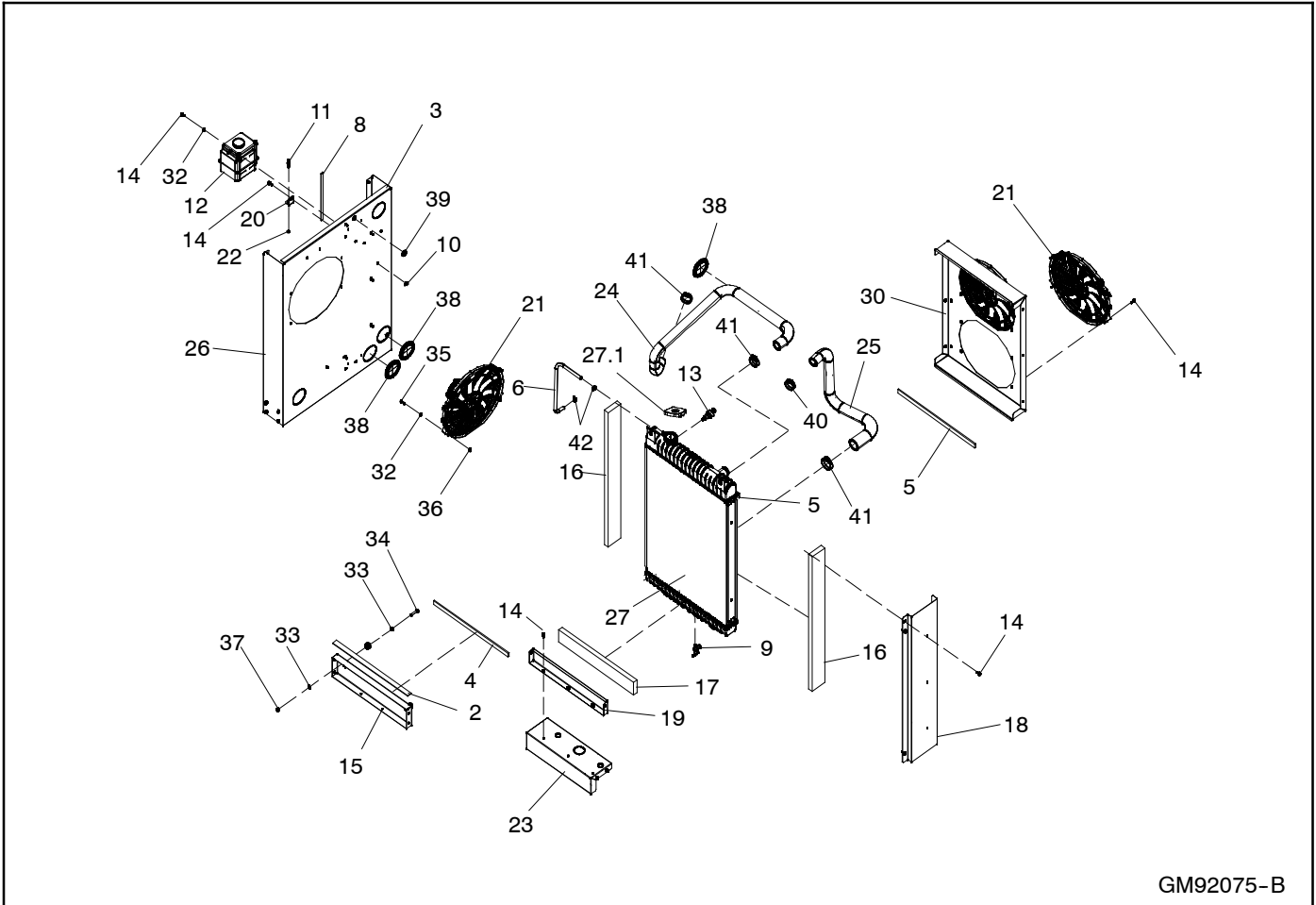

GM92075-B

Cooling System, continued

GM92075-GR2

Item	Part Number	Description	Quantity
2	19000 08075	Foam, gasket seal (3/4" tape)	1
3	19000 08075	Foam, gasket seal (3/4" tape)	1
4	19010 08118	Neoprene, closed cell (1"W x 1/4"T)	1
5	19010 08118	Neoprene, closed cell (1"W x 1/4"T)	2
6	X-386-142	Line, Flex Fuel	1
8	X-6047-31	Channel, U	1
9	278788	Valve, drain (3/8"nptf)	1
10	361567	Base, tie wrap snapin	2
11	GM28823	Sensor, Temperature	1
12	GM47692	Bottle, Overflow	1
13	GM66270	Sensor, Low Coolant Level	1
14	GM78761-1	Screw, Sheetmetal	37
15	GM82973	Mount, Radiator Upper	1
16	GM82979-1	Insulation, Acoustic	2
17	GM82979-2	Insulation, Acoustic	1
18	GM83755	Shroud, Radiator Front	1
19	GM83762	Bracket, Lower Radiator	1
20	GM83899	Bracket, Temperature Sender	1
21	GM83900	Fan Assembly	3
22	GM84247	Nut, 1/8-27 NPT	1
23	GM85643	Mount, Radiator Lower	1
24	GM90237	Hose, Upper Radiator	1
25	GM90238	Hose, Lower Radiator	1
26	GM91063	Panel, Bulkhead	1
27	GM79552	Radiator	1
27.1	GM88429	Radiator Cap	1
30	GM91554	Shroud, Radiator	1
32	M125A-06-80	Washer, Plain	6
33	M125A-08-80	Washer, Plain 8.4 ID x 16.0 OD	4
34	M931-08040-60	Screw, Hex Cap	2
35	M933-06020-60	Screw, Hex Cap	4
36	M982-06-80	Nut, hex elastic stop, 6MM	4
37	M982-08-80	Nut, hex elastic stop, 8MM	2
38	X-284-31	Grommet, round	3
39	X-284-7	Grommet, round	1
40	X-426-19	Clamp, hose, 1.00/2.00 in.	1
41	X-426-16	Clamp, hose, 1.81/2.75 in.	3
42	X-426-9	Clamp, hose, .25/.70 in.	2
43	X-301-49	Plug, Button (not shown)	2

Engine

GM90228-GR1

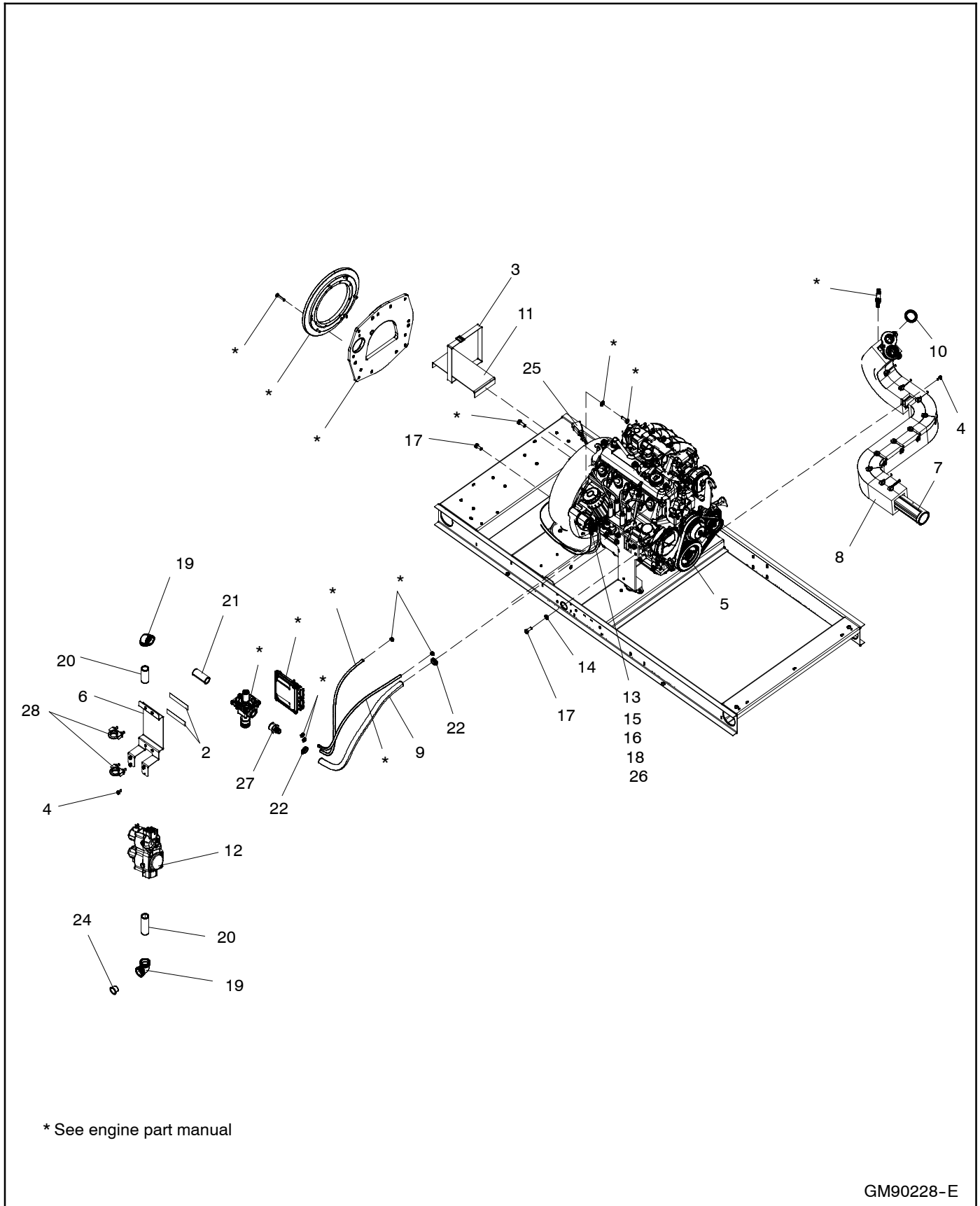

GM90228-E

Engine

GM90228-

Item	Part Number	Description	Quantity
2	32000 00110	Tape, Black Bonding	2
3	GM61432	Strap, Poly Battery	1
4	GM78761-1	Screw, Sheetmetal	5
5	GM87711	Engine Assembly	1
6	GM87838	Bracket, Fuel Solenoid	1
7	GM90277	Pipe, Exhaust	1
8	GM91311	Blanket, Exhaust	1
9	GM91571	Hose, Fuel Line	1
10	GM92753	Exhaust Gasket Set	2
11	GM93422	Support, Battery	1
12	GM96976	Valve, Dual Solenoid	1
13	M125A-08-80	Washer, Plain 8.4 ID x 16.0 OD	2
14	M125A-10-80	Washer, Plain 8.4 ID x 16.0 OD	14
15	M933-08012-60	Screw, Hex Cap	1
16	M934-08-60	Nut, Hex	1
17	M961-10025-82	Screw, Hex Cap	8
18	X-22-5	Washer, Lock	1
19	X-215-15	Elbow, pipe (90 deg x 1"npt)	2
20	X-218-13	Pipe (1"npt x 4.00")	1
21	X-218-22	Pipe, Nipple (1" NPT x 3.00")	2
22	X-426-12	Clamp, hose, .69/1.25 in.	2
24	X-519-20	Plug, Cap	1
25	X-545-244	Cable, Battery	1
26	X-545-245	Cable, Battery	1
27	X-582-15	Connector, hose + Vibra Seal	1
28	X-722-8	Clamp, muffler, 1.37 in.	2

Engine, continued

GM92074-GR1

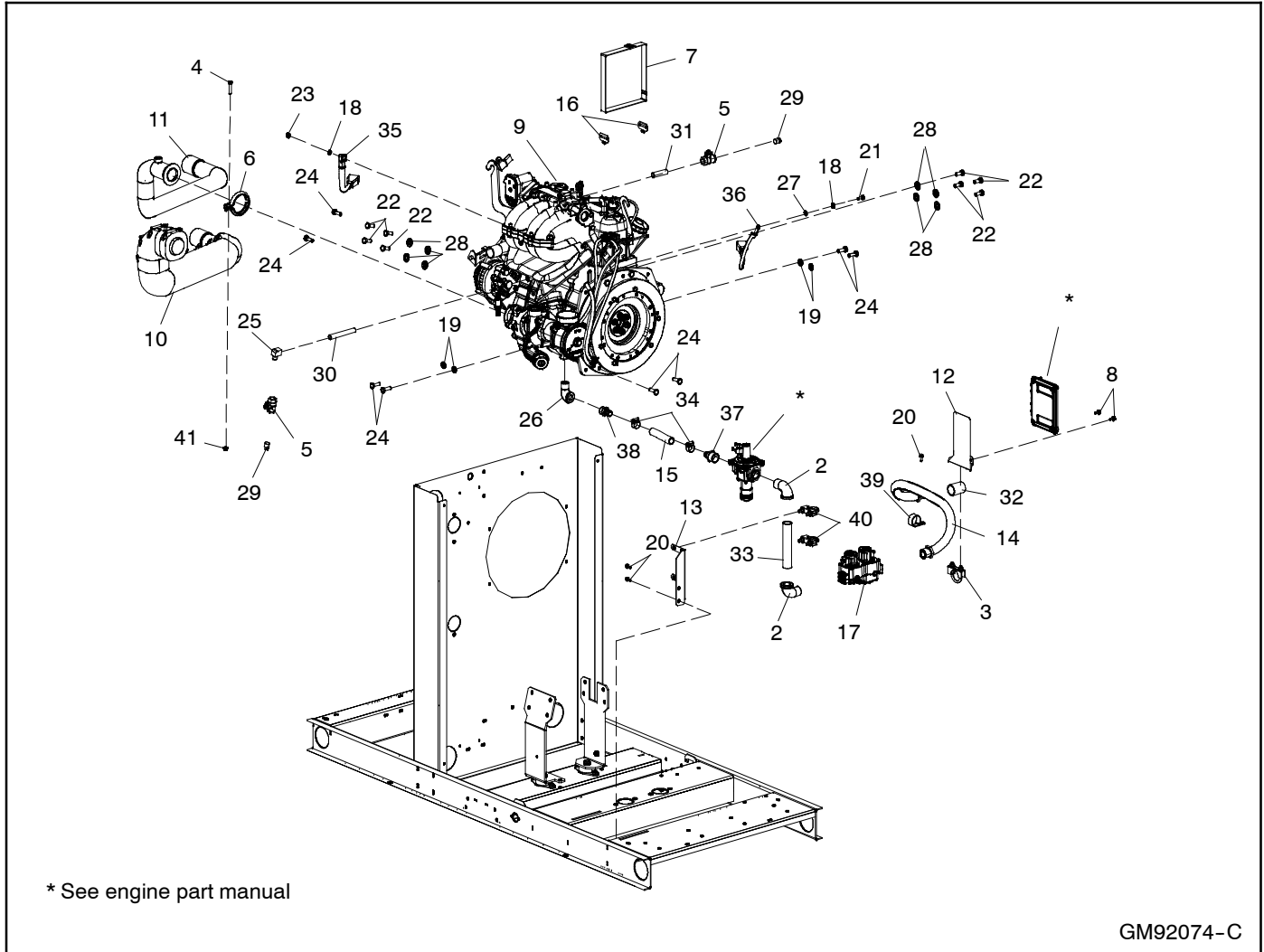

Engine, continued

Item	Part Number	Description	GM92074-GR1
			Quantity
			ModuleNumber GM92074-GR1
2	151385	Elbow, street (90 deg. x 1"nptf)	2
3	237548	Clamp, Muffler	1
4	336851	Screw, hex head machine, special thread	1
5	GM100183	Valve, Shutoff (3/8-18npt)	2
6	GM22535	Clamp, Exhaust (3.34 in.)	1
7	GM61432	Strap, Poly Battery	1
8	GM78761-1	Screw, Sheetmetal	2
9	GM88249	Engine, Gaseous Fuel. Turbo, 2.2L	1
10	GM92079	Blanket, Exhaust	1
11	GM95022	Pipe, Exhaust	1
12	GM95605	Bracket, Fuel Hose Mtg.	1
13	GM95606	Bracket, Fuel Solenoid Mtg.	1
14	GM95607	Hose, Fuel Line	1
15	GM95614	Hose, Fuel Line	1
16	GM96290	Bracket, T-Slot, Strap	2
17	GM96976	Valve, Dual Solenoid	1
18	M125A-08-80	Washer, Plain 8.4 ID x 16.0 OD	1
19	M125A-10-80	Washer, Plain 10.5 ID x 20.0 OD	4
20	M6921-06016-60	Screw, Hex Finge M6x16mm fly thrd js500	3
21	M933-08020-60	Screw, Hex Cap	1
22	M933-10025-82	Screw, Hex Cap	8
23	M934-08-60	Nut, Hex	1
24	M961-10030-60	Screw, Hex Cap	8
25	S-404	Elbow, street (90 deg x 3/8"nptf)+Vibra	1
26	SA-472	Elbow, street (90 deg x 3/4"nptf)	1
27	X-22-10	Washer, lock .391 IDx.681 in. OD	1
28	X-25-26	Washer, Plain	8
29	X-75-10	Plug, pipe (3/8" nptf)	2
30	X-204-21	Pipe (3/8"npt x 4.50")	1
31	X-204-24	Pipe (3/8"npt x 2.5")	1
32	X-216-12	Coupling, pipe (1"npsc)	1
33	X-218-9	Pipe (1"npt x 6.50")	1
34	X-426-12	Clamp, hose, .69/1.25 in.	2
35	X-545-246	Cable, Battery	1
36	X-545-247	Cable, Battery	1
37	X-582-15	Connector, hose + Vibra Seal	1
38	X-582-8	Connector, hose + Vibra Seal	1
39	X-672-39	Clamp	1
40	X-722-8	Clamp, muffler, 1.37 in.	2
41	X-6210-7	Nut, flange spirallock, 5/16-18	1

Nameplate and Decals

GM78523-GR1 Not illustrated

Item	Part Number	Description	Quantity
			ModuleNumber -GR1
1	239789	Decal, notice, neutral bonded to frame	1
2	249808	Decal, warning rotating parts	2
3	249809	Decal, Caution Hot Engine	5
4	249810	Decal, warning hot coolant	1
5	257438	Decal, danger moving rotor	1
6	257441	Decal, warning lifting eye	1
7	258815	Decal, warning voltage backfeed	1
8	273780	Decal, warning explosion	1
9	294520	Decal, danger, high voltage	3
10	GM15299	Decal, Rainproof Enclosure	1
11	GM20577	Decal, Fuel Type	1
12	X-6275-3	Logo, Kohler	3
13	GM81760	Decal, Kohler -RDC2/DC2/VSC	1
14	GM15301	Decal, Power Breaker	1

Skid and Mounting

GM91038-GR1

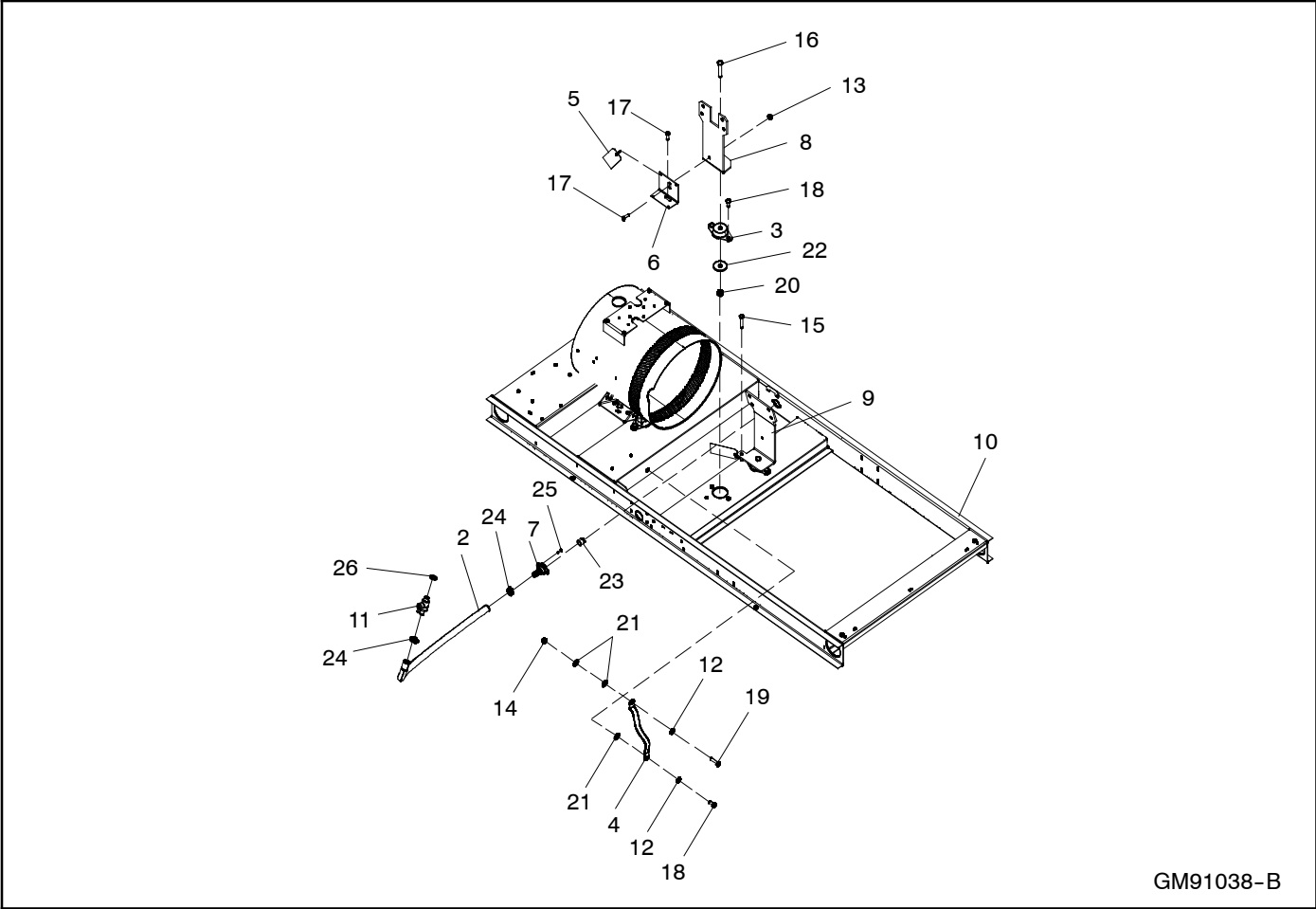

Item	Part Number	Description	Quantity
			ModuleNumber -GR1
2	X-577-27	Hose, rubber, straight, .62 in. ID	1
3	276476	Vibromount	2
4	290418	Strap, Ground (11 in.)	1
5	GM28552	Tag, Hang Shipping Brkt.	2
6	GM51689	Bracket, Shipping	1
7	GM59015	Fitting, Bulkhead Drain	1
8	GM87458	Foot, Engine (RH)	1
9	GM87459	Foot, Engine (LH)	1
10	GM91039	Skid	1
11	GM93089	Valve, Oil Drain	1
12	M125A-10-80	Washer, Plain 8.4 ID x 16.0 OD	2
13	M6923-08-80	Nut, Hex 8mm	1
14	M6923-10-80	Nut, Hex 10mm	1
15	M931-08045-60	Screw, Hex Cap	1
16	M931-12065-60	Screw, Hex Cap	2
16	M125A-12-80	Washer, Plain (not shown)	2
17	M933-08025-60	Screw, Hex Cap	2
18	M933-10020-60	Screw, Hex Cap	5
19	M933-10035-60	Screw, Hex Cap	1
20	M982-12-80	Nut, hex elastic stop	2
21	X-22-15	Washer,lock,.456 IDx1.058 in.OD	3
22	X-25-140	Washer,plain,.531 IDx2in.OD	2
23	X-75-58	Plug, Pipe	1
24	X-426-10	Clamp, hose, .5/1 in.	2
25	X-781-22	Rivet, Pop	2
26	X-6278-7	Washer, nylon, .75 ID x 1.063 in. OD	1

Alternator and Mounting

GM87474-

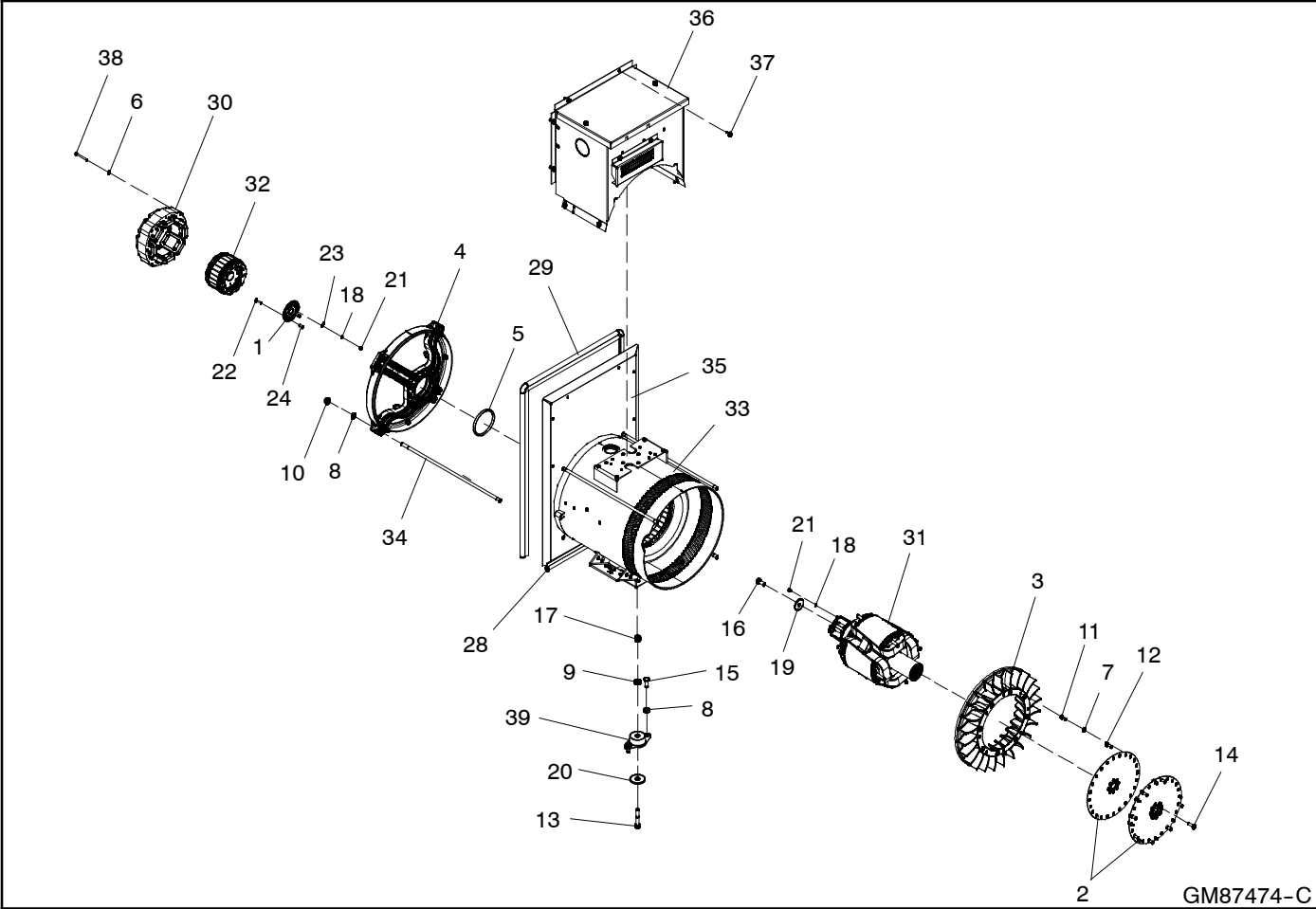

GM87474-C

Alternator and Mounting

GM87474-

Item	Part Number	Description	Quantity
1	A-229152	PCB assembly	1
2	GM87122	Disc, Drive (4D backplate)	2
3	GM87123	Fan, Alternator (4D/4E)	1
4	GM87126	Bracket, End (4D/4E)	1
5	GM87132	O-Ring	1
6	M125A-05-80	Washer, Plain	4
7	M125A-06-80	Washer, Plain	8
8	M125A-10-80	Washer, Plain 8.4 ID x 16.0 OD	4
9	M125A-12-80	Washer, Plain	2
10	M6923-10-80	Nut, Hex 10mm	4
11	M912-06016-60	Screw, Socket Head Cap	8
12	M912-08020-92	Screw, Socket Head Cap	8
13	M931-12065-60	Screw, Hex Cap	2
14	M933-08025-82	Screw, Hex Cap	8
15	M933-10025-60	Screw, hex cap,fully thrd M10 x 25mm	4
16	M933-10025-82	Screw, Hex Cap	1
16	X-22-1	Washer, lock (not shown)	1
17	M982-12-80	Nut, hex elastic stop	2
18	X-22-7	Washer,Lock.172 ID x.333 in.OD	5
19	X-25-129	Washer,plain,.384 ID x 1.628 in.OD	1
20	X-25-140	Washer,plain,.531 IDx2in.OD	2
21	X-51-8	Screw, Machine	5
22	X-67-135	Screw, hex washer, thread-forming	3
23	X-283-3	Terminal, ring, male, 16-14 AWG	3
24	X-712-17	Spacer, .312 OD, .56 in.	3
28	X-6422-15	Seal, Push-On Trim	1
29	X-6422-42	Seal, Push-On Trim	1
30	GC31594	Exciter, Field Assembly	1
31	GC87121-3	Rotor Assy, 4D5.0 Backplate	1
32	GC87128	Exciter Armature Assy (40mm)	1
33	See chart	Stator Assy, 4E5.0 2.2L GW	1
34	GM87134-3	Stud, M10-1.50 x 480mm	4
35	GM87978	Duct, Alt. Intake (4D)	1
36	See chart	Box, Saddle	1
37	GM78761-1	Screw, Sheetmetal	10
38	M933-05050-60	Screw, Hex Cap	4
39	276309	Vibromount	2

Use this table to identify part numbers of items 33, 36.

Module No.	Description	Part Number	
		Item 33, Stator	Item 36, Saddle Box
GM87474-MA1	4E5.0	GC90418-3	GM93034-3
GM87474-MA2	4D5.0, 1 Ph.	GC90416-3	GM93034-5

Alternator and Mounting, continued

Saddle Box GM93034-

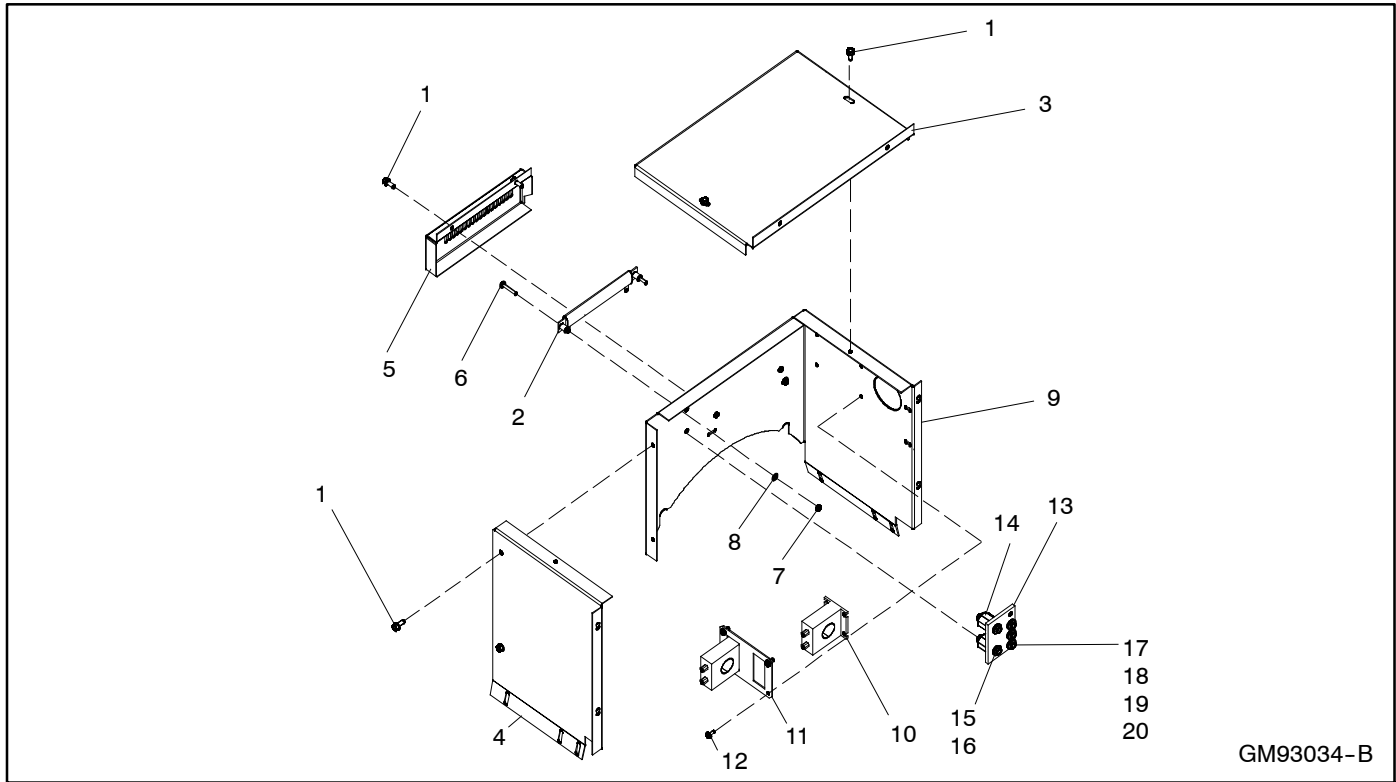

GM93034-B

Item	Part Number	Description	Qty
1	GM78761-1	Screw, Sheetmetal	6
2	GM83895	Resistor	1
3	GM92873	Panel, Cover	1
4	GM92874	Panel, Side	1
5	GM92902	Guard, Resistor	1
6	M7985A-05030-20	Screw, Pan Head Machine	2
7	M934-05-50	Nut, Hex 5mm	2
8	X-22-11	Lock .262 ID x .469 OD	2
9	See chart	Panel, Side	1
9	See chart	Bracket, Saddle Box (not shown)	1
10	See chart	Transformer, Current	2
11	See chart	Bracket, CT Mounting	1
12	See chart	Screw, Tapping	4
13	See chart	Bus, Neutral	1
14	See chart	Insulator, Standoff	2
15	M6923-06-80	Nut, Hex 6mm	2
16	M933-06010-60	Screw, hex cap	2
17	M933-06016-60	Screw, hex cap, M6x16mm, js500 full	2
18	M933-06025-20	Screw, Hex Cap	3
19	X-25-40	Washer, plain, .281 ID x .625 in.OD	7
20	X-6086-24	Washer, Spring	5

Use this table to identify part numbers of items 9-13.

Part No.	Part Number						
	Item 9, Panel	Item 9, Bracket	Item 10, Transformer	Item 11, Bracket	Item 12, Screw	Item 13, Bus	Item 14, Insulator
GM93034-1	GM92875	-	GM16252	GM92901	X-67-156	-	-
GM93034-2	GM92875	-	GM16252	GM92901	X-67-156	GM80901	X-6128-35
GM93034-3	GM93019	-	-	-	-	-	-
GM93034-4	GM93019	GM93035	-	-	-	GM80901	X-6128-35
GM93034-5	GM93019	-	-	-	-	GM80901	X-6128-35

Notes

Alternator and Mounting, continued

GM97041-

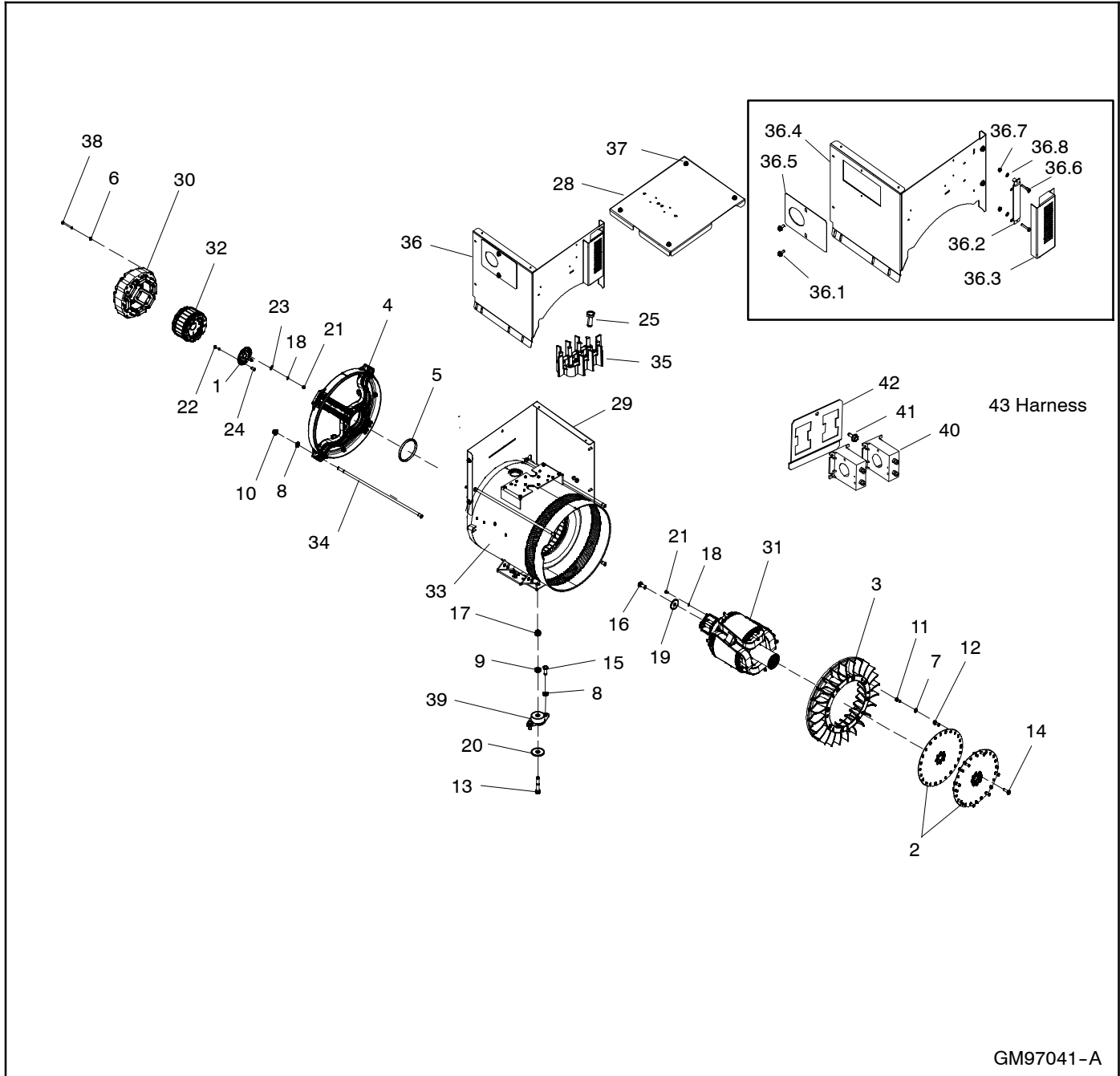

GM97041-A

GM97041-

Item	Part Number	Description	Quantity
1	A-229152	PCB assembly	1
2	GM87122	Disc, Drive (4D backplate)	2
3	GM87123	Fan, Alternator (4D/4E)	1
4	GM87126	Bracket, End (4D/4E)	1
5	GM87132	O-Ring	1
6	M125A-05-80	Washer, Plain	4
7	M125A-06-80	Washer, Plain	8
8	M125A-10-80	Washer, Plain 8.4 ID x 16.0 OD	4
9	M125A-12-80	Washer, Plain	2
10	M6923-10-80	Nut, Hex 10mm	4

Alternator and Mounting, continued

GM97041-

Item	Part Number	Description	Quantity
11	M912-06016-60	Screw, Socket Head Cap	8
12	M912-08020-92	Screw, Socket Head Cap	8
13	M931-12065-60	Screw, Hex Cap	2
14	M933-08025-82	Screw, Hex Cap	8
15	M933-10025-60	Screw, hex cap,fully thrd M10 x 25mm	4
16	M933-10025-82	Screw, Hex Cap	1
16	X-22-1	Washer, lock (not shown)	1
17	M982-12-80	Nut, hex elastic stop	2
18	X-22-7	Washer,Lock.172 ID x.333 in.OD	5
19	X-25-129	Washer,plain,.384 ID x 1.628 in.OD	1
20	X-25-140	Washer,plain,.531 IDx2in.OD	2
21	X-51-8	Screw, Machine	5
22	X-67-135	Screw, hex washer, thread-forming	3
23	X-283-3	Terminal, ring, male, 16-14 AWG	3
24	X-712-17	Spacer, .312 OD, .56 in.	3
25	M932-06016-60	Screw, Socket Head Cap	2
28	GM96342	Cover, Saddle Box	1
29	GM96988	Panel, Side	1
30	See chart	Exciter, Field Assembly	1
31	See chart	Rotor Assy	1
32	See chart	Exciter Armature Assy	1
33	See chart	Stator Assy, 4E5.0 2.2L GW	1
34	See chart	Stud	4
35	GM90316	Terminal Block	1
36	GM96989	Subassy, Saddle Box	1
37	GM78761-1	Screw, Sheetmetal	12
38	See chart	Screw, Hex Cap	4
39	See chart	Vibromount	2
36.1	GM78761-1	Screw, Sheetmetal	4
36.2	GM83895	Resistor	1
36.3	GM92902	Guard, Resistor	1
36.4	GM96986	Panel, Side	1
36.5	GM96987	Panel, Harness	1
36.6	M7985A-05030-20	Screw, Pan Head Machine	2
36.7	M934-05-50	Nut, Hex 5mm (NRP)	2
36.8	X-22-11	Lock .262 ID x .469 OD (KM)	2
40	See chart	Transformer	2
41	See chart	Screw, Sheetmetal	2
42	See chart	Bracket, CT Mounting	2
43	See chart	Harness, Wiring Current Transformer	2

Use this table to identify part numbers of items 30-38.

Module No.	Description	Part Number					
		Item 30, Exciter	Item 31, Rotor	Item 32, Exciter Armature	Item 33, Stator	Item 34, Stud	Item 38, Screw
GM97041-MA1	4E5.0	GC31594	GC87121-3	GC87128	GC90418-3	GM87134-7	M933-05050-60
GM97041-MA2	4D5.0, 1 Ph.	GC31594	GC87121-3	GC87128	GC90416-3	GM87134-7	M933-05050-60
GM97041-MA3	4E5.6	GC31594	GC87121-4	GC87128	GC90418-4	GM87134-7	M933-05050-60
GM97041-MA4	4D8.3	GC87131	GC87121-5	GC87129	GC90416-5	GM87134-5	M931-05070-60
GM97041-MA5	4E8.3	GC87131	GC87121-5	GC87129	GC90418-5	GM87134-5	M931-05070-60
GM97041-MA6	4D8.3	GC87131	GC87121-5	GC87129	GC90416-5	GM87134-5	M931-05070-60

Use this table to identify part numbers of item 39-43.

Module No.	Part Number				
	Item 39, Vibromount	Item 40, Transformer	Item 41, Screw	Item 42, Bracket	Item 43, Harness
GM97041-MA1	267309	-	-	-	-
GM97041-MA2	267309	-	-	-	-
GM97041-MA3	267309	GM16252	GM78761-1	GM94789	GM85198
GM97041-MA4	324073	GM16252	GM78761-1	GM94789	GM85198
GM97041-MA5	324073	GM16252	GM78761-1	GM94789	GM85198
GM97041-MA6	324073	-	-	-	-

Control and Harness

GM91287-

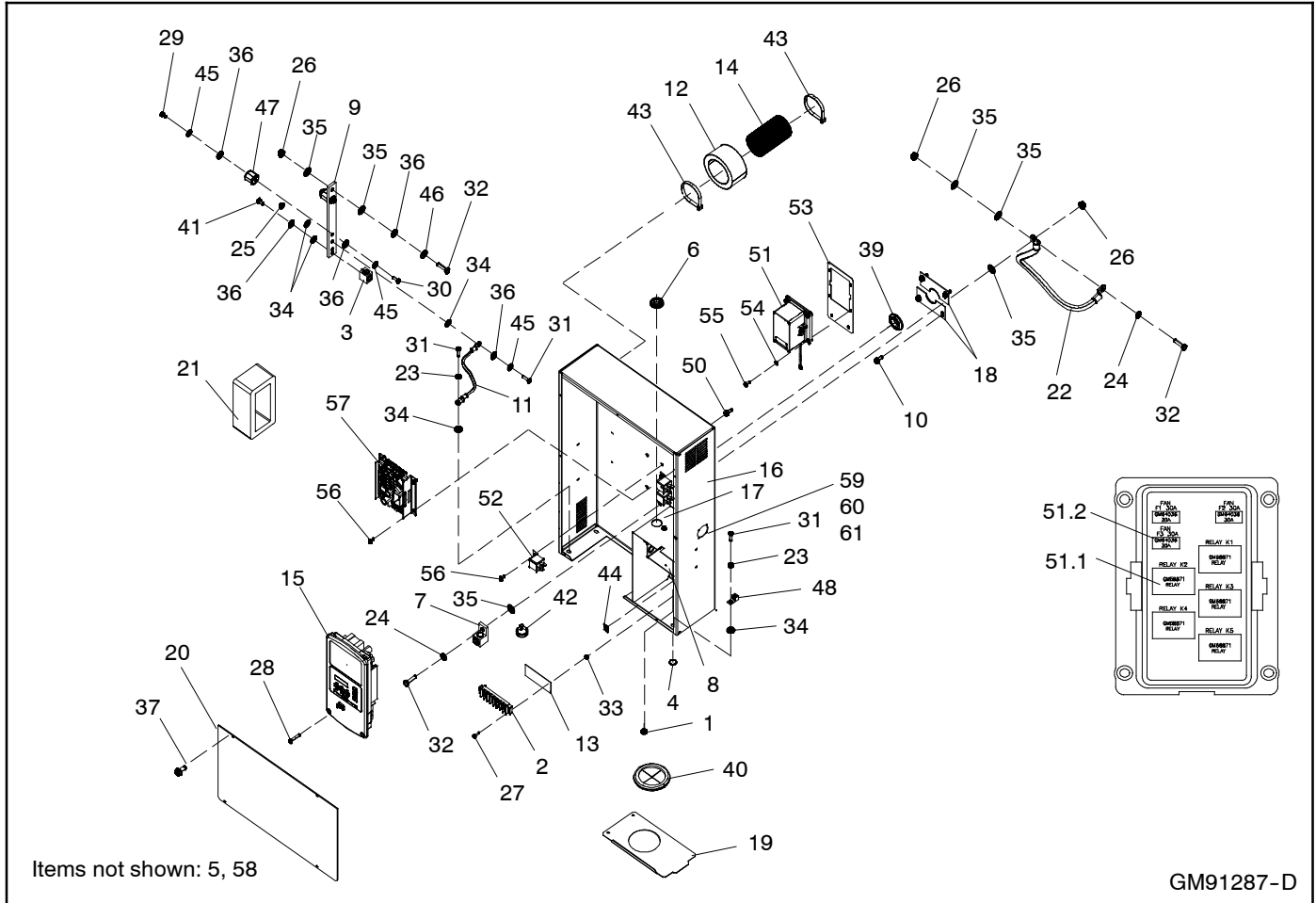

Control and Harness

GM91287-

Item	Part Number	Description	Quantity
1	200705	Grommet, round	1
2	246115	Terminal block	1
3	297712	Lug, terminal	1
4	345211	Decal, ground	3
5	357477	Cable, Patch, 3 Ft. RJ-45	1
6	D-1128	Grommet, round	1
7	GM28413	Lug, Terminal	1
8	GM78536	Divider, Junction Box	1
9	GM78547	Bus, Neutral	1
10	GM78761-1	Screw, Sheetmetal	4
11	GM82875	Lead	1
12	GM82972	Insulation, Acoustic Foam 2"	1
13	GM84245	Decal, Terminal Block	1
13	GM94607	Decal, Warning (not shown)	1
14	GM85171-1	Conduit, Convoluted	1
15	GM84962	Service Controller, RDC2	1
16	GM91133	Box, Junction	1
17	GM91306	Divider, Junction Box	1
18	GM93075	Plate, Harness	2
19	GM93731	Plate, Conduit Cover	1
20	GM93736	Plate, Access	1
21	GM93741	Insulation, Acoustic Foam 2"	1
22	LK-0618-3637	Lead	1
23	M125A-06-80	Washer, Plain	3
24	M125A-08-80	Washer, Plain 8.4 ID x 16.0 OD	2
25	M6923-06-80	Nut, Hex 6mm	2
26	M6923-08-80	Nut, Hex 8mm	3
27	M7985A-04016-20	Screw, Pan Head Machine	2
28	M7985A-05030-20	Screw, Pan Head Machine	2
29	M933-06010-60	Screw, Hex Cap	2
30	M933-06016-60	Screw, Hex Cap	2
31	M933-06020-60	Screw, Hex Cap	5
32	M933-08030-60	Screw, Hex Cap	3
33	M934-04-50	Nut, Hex 4mm	2
34	X-22-12	Washer, lock.262 IDx.743 in.OD	7
35	X-22-16	Washer, lock.326 IDx.883 in.OD	6
36	X-25-20	Washer, Flat .312 ID x.75 OD	5
37	X-6216-1	Screw, Tapping	12
39	X-284-3	Grommet, round	1
40	X-284-31	Grommet, round	1
41	X-465-2	Bolt, Hex Cap	1
42	X-468-1	Cable Tie	1
43	X-468-4	Cable Tie	2
44	X-6048-2	Jumper, term block 2 pos	1
45	X-6086-24	Washer, Spring	5
46	X-6086-25	Washer, Spring	1
47	X-6128-35	Insulator, Standoff	2
48	X-6207-1	Lug, terminal, aluminum	2
50	GM78761-1	Screw, Sheetmetal	2
51	See chart	Harness, Genset	1
51.1	GM58871	Relay	5
51.2	GM64036	Fuse, 30A, 32V. (12V)	3
52	See chart	Relay, 12 VDC	-
53	GM93036	Bracket, Fuse Box	1
54	X-22-9	Washer, lock.20 ID x.373 in.OD	4
55	X-50-1	Screw, Machine	4
56	X-67-156	Screw, Tapping	7
57	GM88453	Board, Assembly 4D Activator	1
59	X-49-40	Screw, Machine	4
60	X-25-9	Washer, plain, .156 ID x .375 in.OD	4
61	X-74-6	Nut, hex machine screw, 4-40	4
	GM97332	Subassy, Bus Bar (includes items 3, 9, 11, 25,30,31,34,36, 41, 45, 47)	

Module No.	Part Number	
	Item 51, Harness	Item 52, Relay (Qty)
GM91287-GR1	GM91459	GM49746 (3)
GM91287-GR4	GM96420	GM49746 (4)

Control and Harness, continued

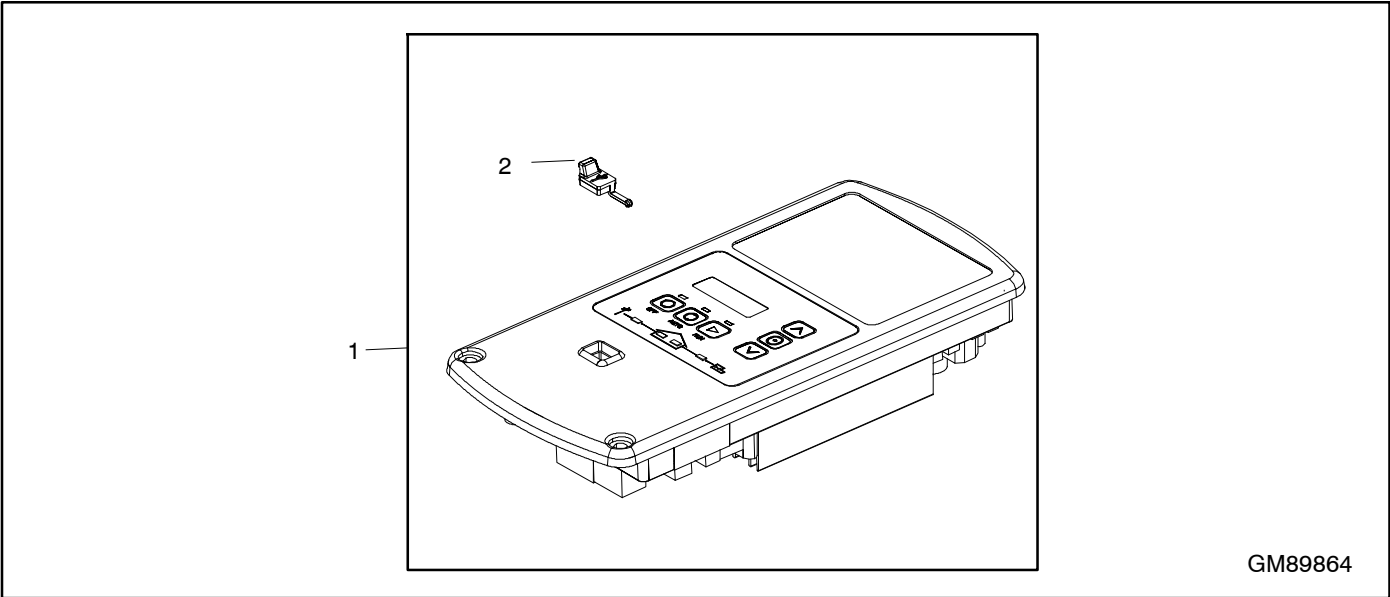

Item	Part Number	Description	Quantity
1	GM92089	Controller, Service RDC2 (ref. GM89864-1)	1
2	GM89865	Plug, USB	1

Notes

Circuit Breaker and Mounting

GM91321-

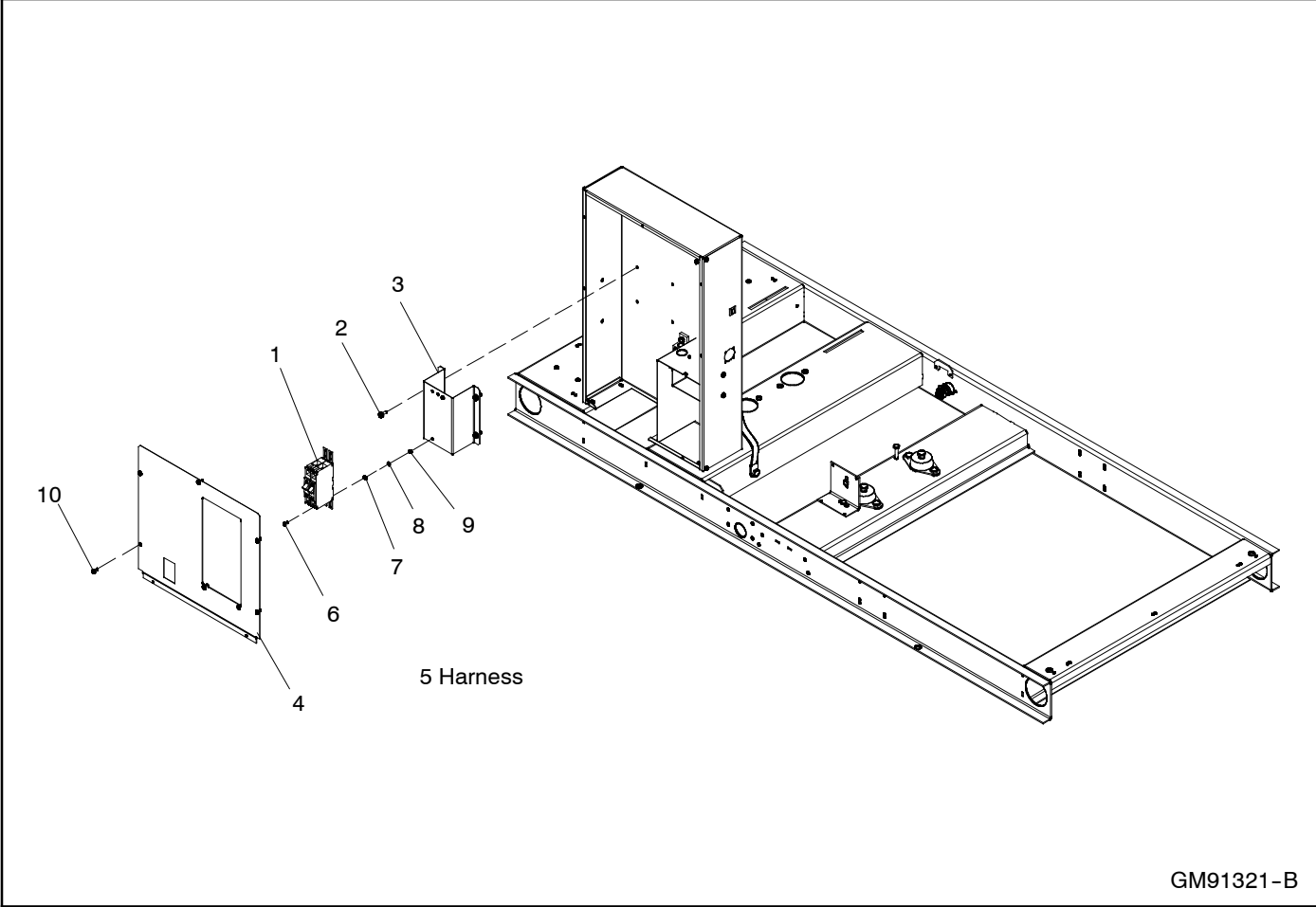

GM91321-B

Circuit Breaker and Mounting

GM91321-

Item	Part Number	Description	Quantity
1	See chart	Breaker, Circuit	1
2	GM78761-1	Screw, Sheetmetal	4
3	See chart	Bracket, Circuit Breaker	1
4	See chart	Cover, Junction Box	1
5	See chart	Harness,Circuit Breaker Wiring	1
6	See chart	Screw, Pan Head Machine	2
7	See chart	Washer,plain	2
8	See chart	Washer, lock,	2
9	M934-04-50	Nut, Hex 4mm	2
10	X-6216-1	Screw, Phillips hex crimpfitpe	5

Module No.	Part Number						
	Item 1, Circuit Breaker	Item 3, Bracket	Item 4, Cover	Item 5, Harness	Item 6, Screw	Item 7, Washer	Item 8, Washer
GM91321-MA1	GM22481	GM93427	GM99077	GM93482	M7985A-04010-20	M125A-04-80	X-19-1
GM91321-MA2	GM93425	GM93427	GM99077	GM93482	M7985A-04010-20	M125A-04-80	X-19-1
GM91321-MA3	GM47475-1	GM91322	GM99079	GM93483	M7985A-04080-20	X-25-45	X-22-20
GM91321-MA4	GM22482	GM93427	GM99078	GM93484	M7985A-04010-20	M125A-04-80	X-19-1
GM91321-MA13	GM47475-8	GM91322	GM99079	GM93663	M7985A-04080-20	X-25-45	X-22-20
GM91321-MA16	GM47475-7	GM91322	GM99079	GM97557	M7985A-04080-20	X-25-45	X-22-20
GM91321-MA17	GM96421	GM93427	GM99077	GM97557	M7985A-04010-20	M125A-04-80	X-19-1
GM91321-MA18	GM47475-14	GM91322	GM99079	GM93483	M7985A-04080-20	X-25-45	X-22-20
GM91321-MA19	GM47475-2	GM91322	GM99079	GM93483	M7985A-04080-20	X-25-45	X-22-20
GM91321-MA20	GM62495-1	GM93646	GM99080	GM93485	M7985A-04080-20	X-25-45	X-22-20
GM91321-MA21	GM62495-3	GM93646	GM99080	GM100251	M7985A-04080-20	X-25-45	X-22-20

Sound Shield Enclosure

GM91044-

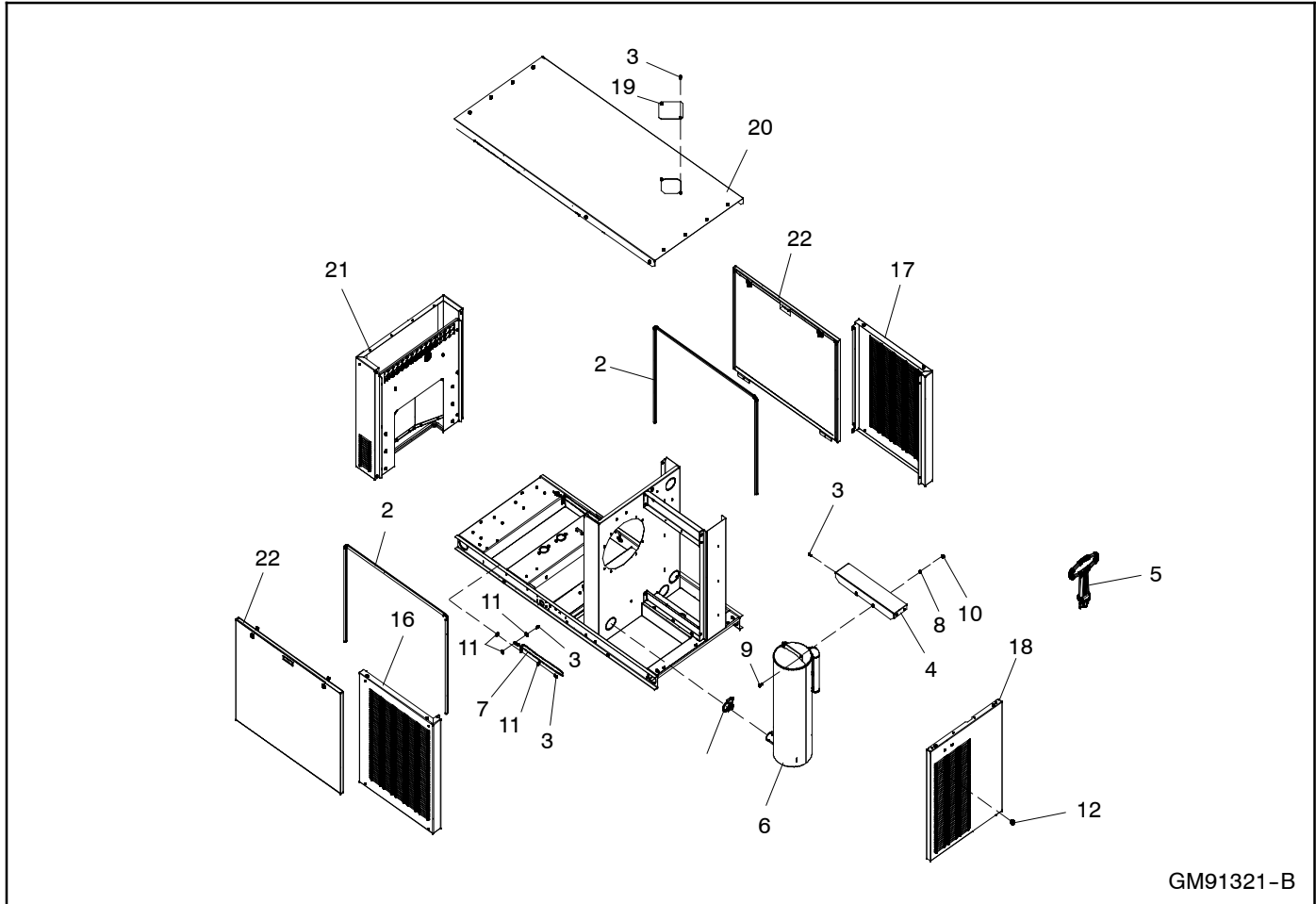

GM91321-B

Item	Part Number	Description	ModuleNumber	Quantity
2	25493 00006	Seal, Push-On Trim		2
3	GM78761-1	Screw, Sheetmetal		37
4	GM82880	Bracket, Exhaust Mounting		1
5	GM82922	Latch, Opening Tool		2
6	GM88560	Silencer		1
7	LK-1036-1515	Lead		2
8	M125A-08-80	Washer, Plain 8.4 ID x 16.0 OD		2
9	M933-08020-60	Screw, Hex Cap		2
10	M982-08-80	Nut, hex elastic stop, 8MM		2
11	X-22-12	Washer, lock		4
11	M125A-06-80	Washer, Plain (not shown)		4
12	X-468-1	Cable Tie		1
13	X-722-2	Spacer, .312 OD, .56 in.		1
16	See chart	Panel, Enclosure Front (RH)		1
17	See chart	Panel, Enclosure Front (LH)		1
18	See chart	Panel, Front Enclosure		1
19	See chart	Cover, Radiator Fill		1
20	See chart	Roof Sub Assy, Enclosure		1
21	See chart	Panel, End Sub Assy, Enclosure		1
22	See chart	Panel, Access Assy, Enclosure		2

Use this table to identify part numbers of items 16-22.

Module No.	Description	Part Number						
		Item 16, Panel (RH)	Item 17, Panel (LH)	Item 18, Panel, Front	Item 19, Cover	Item 20, Roof	Item 21, Panel Assy.	Item 22, Panel Assy.
GM91044-MA1	Steel	GM90240	GM90241	GM90242	GM90245	GM91040	GM91105	GM91363
GM91044-MA2	Al.	GM88395	GM88396	GM88397	GM81601	GM91365	GM91376	GM91363

Sound Shield Enclosure

GM97051

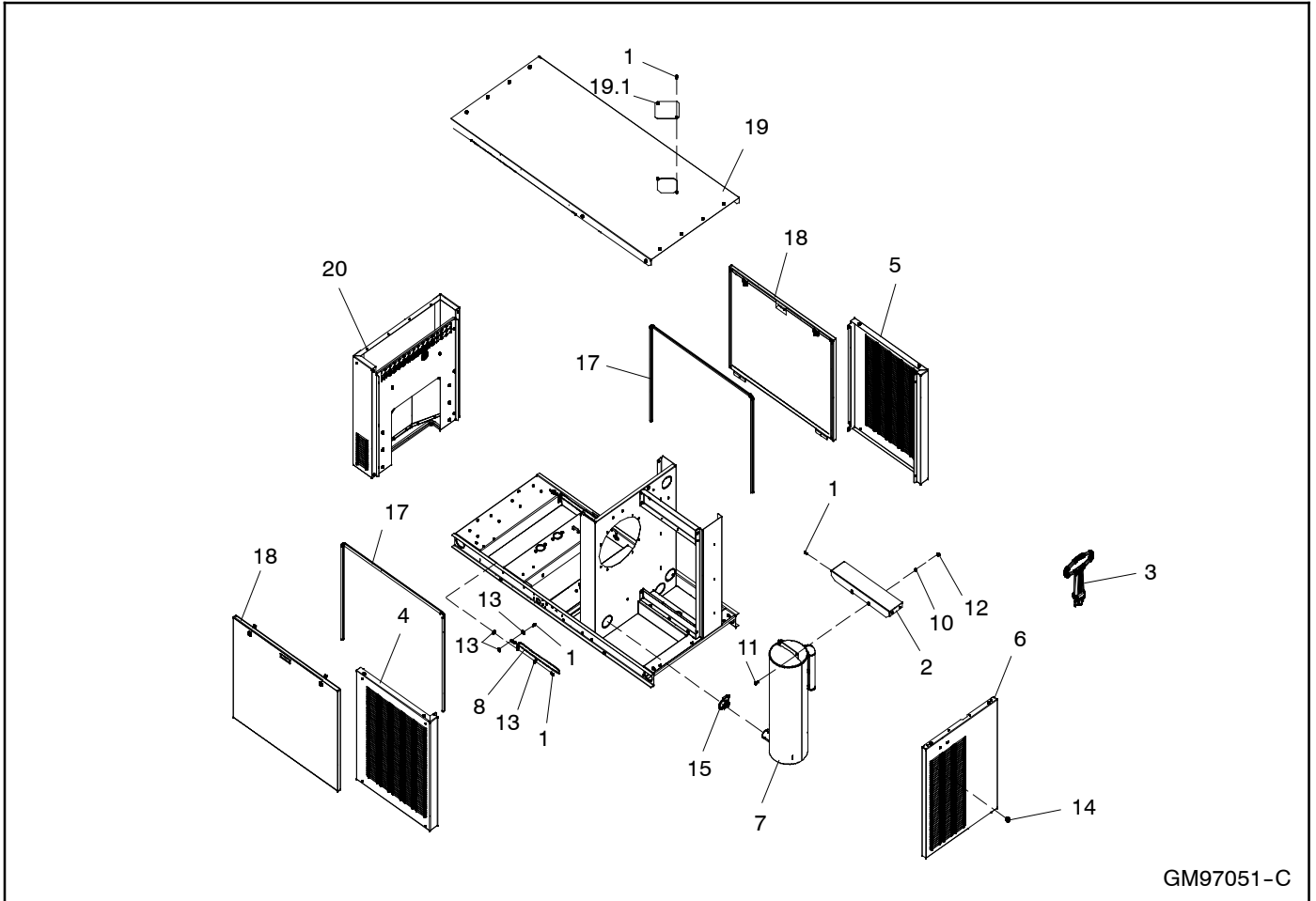

GM97051-C

Item	Part Number	Description	ModuleNumber Quantity
1	GM78761-1	Screw, Sheetmetal	35
2	GM82880	Bracket, Exhaust Mounting	1
3	GM82922	Tool, Latch Opening	2
4	GM88395	Panel, Enclosure Front (RH)	1
5	GM88396	Panel, Enclosure Front (LH)	1
6	GM88397	Panel, Front Enclosure	1
7	GM88560	Silencer	1
8	LK-1036-1515	Lead	2
9	M125A-06-80	Washer, Plain (not shown)	4
10	M125A-08-80	Washer, Plain 8.4 ID x 16.0 OD	2
11	M933-08020-60	Screw, Hex Cap	2
12	M982-08-80	Nut, hex elastic stop, 8MM	2
13	X-22-12	Washer, lock	4
14	X-468-1	Cable Tie	1
15	X-722-2	Spacer, .312 OD, .56 in.	1
17	25493 00006	Seal, Push-On Trim	2
18	See chart	Panel, Access Assy, Enclosure	2
19	See chart	Roof Sub Assy, Enclosure	1
19.1	GM81601	Cover, Radiator Fill	1
20	See chart	Panel, End Sub Assy, Enclosure	1

Use this table to identify part numbers of items 18-20.

Module No.	Part Number			
		Item 18, Panel Assy.	Item 19, Roof Assy.	Item 20, Panel Assy.
GM97051-MA1	24/30RCL	GM91363	GM96248	GM97043-1
GM97051-MA2	30/38RCLB	GM91363	GM96248	GM97043-2

Literature

Not illustrated

Item	Part Number	Description	Quantity			
			527	528	530	531
	TP-6479	Warranty, 5-Yr., Standby	1	1	1	1
	TP-6901	O/M Engine KG2204/T 2.2L LPG/NG	1	1	1	1
	TP-6902	S/M Engine KG2204/T 2.2L LPG/NG	1	1	1	1
	TP-6903	S/M Kohler KG2204/T 2.2L LPG/NG Diagnostic	1	1	1	1
	TP-6904	P/C Engine KG2204/T 2.2L LPG/NG	1	1	1	1
	TP-6905	O/M 24/30RCL, 38RCLB Res/Coml	1	1	1	1
	TP-6906	I/M 24/30RCL, 38RCLB Res/Coml	1	1	1	1
	TP-6907	S/M 24/30RCL, 38RCLB Res/Coml	1	1	1	1
	TP-6908	P/C 24/30RCL, 38RCLB Res/Coml	1	1	1	1
	TP-6878	S/M 10-40 kW with 4D/4E Alternators	1	1	1	1

Optional Kits

Qty.	Description	Part No.
------	-------------	----------

Battery, 1/12V, 650CCA, Wet **GM89020-KP1**
 1 Battery, wet charged (12V, 650 CCA) 256984

Block Heater 500W, 120V **GM90235-KP1**
 1 Block Heater, 500W, 120V GM95436
 1 Shield, Heat GM100208
 1 Bracket, Block Heater Mtg. GM78546
 1 Pipe, Nipple (3/8" npt x 2.00") X-204-6
 1 Coupling, pipe (3/8" npsc) X-216-23
 1 Hose, .63 in. ID, 30 in. X-312-24
 1 Hose, .63 ID, 13.75 in. X-312-54
 4 Clamp, hose, .69/1.25 in. X-426-12
 2 Connector, hose + Vibra Seal X-582-2

Block Heater 500W, 240V **GM90235-KP2**
 1 Block Heater, 500W, 240V GM95437
 1 Shield, Heat GM100208
 1 Bracket, Block Heater Mtg. GM78546
 1 Pipe, Nipple (3/8" npt x 2.00") X-204-6
 1 Coupling, pipe (3/8" npsc) X-216-23
 1 Hose, .63 in. ID, 30 in. X-312-24
 1 Hose, .63 ID, 13.75 in. X-312-54
 4 Clamp, hose, .69/1.25 in. X-426-12
 2 Connector, hose + Vibra Seal X-582-2

Fuel Lines, Flexible **GM13706-KA4**
 1 Pipe (1" npt x 1.50") X-218-24
 1 Fuel line, flexible (1.00" ID x 18") X-504-21

Heater, Battery Wrap **GM79481-KP1**
 1 Heater, battery wrap 336814

Kit, Heater, Oil Pan 150W 120V **GM93357-KP1-QS**
 1 Heater, Oil Pan GM93424
 1 TT Oil Pan Heater, Res/Coml TT-1633

Kit, Heater, Oil Pan 150W, 240V **GM93357-KP2**
 1 Heater, Oil Pan GM93486
 1 TT Oil Pan Heater, Res/Coml TT-1633

OnCue Plus, RDC2/DC2 Controller **GM81385-KA1**
 1 OnCue Plus Welcome Letter, Res/Coml G18-246
 1 OnCue App Quick Start Guide G18-247
 1 Decal, OnCue Activation Code GM81386
 1 Connector, RJ45 Female to RJ45 Female GM84651
 1 O/M OnCue Plus Res/Coml TP-6928

OnCue Plus, RDC2/DC2/VSC **GM81385-KP2-QS**
 1 OnCue Plus Welcome Letter, Res/Coml G18-246
 1 OnCue App Quick Start Guide G18-247
 1 Decal, OnCue Activation Code GM81386
 1 Connector, RJ45 Female to RJ45 Female GM84651
 1 O/M OnCue Plus Res/Coml TP-6928

OnCue Plus, Wireless, RDC2/DC2/VSC **GM81385-KP3-QS**
 1 OnCue Plus Welcome Letter, Res/Coml G18-246
 1 OnCue App Quick Start Guide G18-247
 1 Decal, OnCue Activation Code GM81386
 1 Kit, Wireless Router GM91273
 1 O/M OnCue Plus Res/Coml TP-6928
 1 Install Guide WiFi Kit Res/Coml TT-1618

Maintenance kit - 2.2L NA Engine
 (includes oil, oil filter, air filter, spark plugs, and instructions (TT-1445))
 1 Kit, Residential Maintenance GM93396-SKP1-QS

Maintenance kit - 2.2L Turbo Engine
 (includes oil, oil filter, air filter, spark plugs, and instructions (TT-1445))
 1 Kit, Residential Maintenance GM100209-SKP1-QS

Qty.	Description	Part No.
------	-------------	----------

Load Control Module, w/ Harness **GM77177-KP1-QS**
 1 Load Control Module Assy, w/ Harness GM77177-1
 1 Decal, CSA 297721
 1 Decal, equipment grd (NRP) 344295
 2 Insert, threaded, #10-24 346258
 1 Dimension Print, Load Control Module ADV-8198
 4 Gasket GM20990
 2 Label, Blank GM24703
 1 Decal, 120VAC Only GM75393
 1 Plate, Mounting GM77176
 4 Relay GM77178
 1 Cover w/ Decals, Load Shed GM77191
 1 Enclosure, Load Shed GM79445
 1 Harness, Load Control GM80092
 1 Harness, Relay Control GM80673
 1 Indicator, Load Status GM80879
 1 Decal, Wiring Diagram GM80950
 2 Decal, Warning GM81264
 1 PCB Assy, RDC2 Load Control GM81372-1
 1 Transformer, Current GM83929
 1 Decal, LCM - w/ whip GM84656-1
 1 TT Load Control Module, Res/Comm TT-1574
 1 Terminal block X-405-2
 3 Washer X-6086-23
 3 Lug, terminal, aluminum X-6207-3

Optional Kits, continued

Qty.	Description	Part No.
------	-------------	----------

Load Control Module, w/ Terminal Blocks

GM77177-KP2-QS

1	Load Control Module Assy, w/ Term.	GM77177-2
1	Decal, equipment grd (NRP)	344295
2	Insert, threaded, #10-24	346258
1	Dimension Print, Load Control Module	ADV-8198
4	Gasket	GM20990
1	Decal, Nameplate	GM21291
2	Label, Blank	GM24703
1	Decal, 120VAC Only	GM75393
1	Plate, Mounting	GM77176
4	Relay,	GM77178
1	Cover w/ Decals, Load Shed	GM77191
1	Enclosure, Load Shed	GM79445
1	Harness, Relay Control	GM80673
8	Harness, Terminal Block	GM80674
4	Block, Terminal	GM80862
1	Indicator, Load Status	GM80879
1	Marker, Strip	GM80949
1	Decal, Wiring Diagram	GM80950
2	Decal, Warning	GM81264
1	PCB Assy, RDC2 Load Control	GM81372-1
1	Diagram, Wiring Load Control	GM81374
1	Diagram, Schematic Load Control	GM81638
1	Transformer, Current	GM83929
1	TT Load Control Module, Res/Comm	TT-1574
1	Terminal block	X-405-2
3	Washer	X-6086-23
3	Lug, terminal, aluminum	X-6207-3

Load Control Module, w/ Harness, CSA

GM77177-KP3-QS

1	Load Control Module Assy, w/ Harness	GM77177-1
1	Decal, CSA	297721
1	Decal, equipment grd (NRP)	344295
2	Insert, threaded, #10-24	346258
1	Dimension Print, Load Control Module	ADV-8198
4	Gasket	GM20990
2	Label, Blank	GM24703
1	Decal, 120VAC Only	GM75393
1	Plate, Mounting	GM77176
4	Relay	GM77178
1	Cover w/ Decals, Load Shed	GM77191
1	Enclosure, Load Shed	GM79445
1	Harness, Load Control	GM80092
1	Harness, Relay Control	GM80673
1	Indicator, Load Status	GM80879
1	Decal, Wiring Diagram	GM80950
2	Decal, Warning	GM81264
1	PCB Assy, RDC2 Load Control	GM81372-1
1	Transformer, Current	GM83929
1	Decal, LCM - w/ whip	GM84656-1
1	TT Load Control Module, Res/Comm	TT-1574
1	Terminal block	X-405-2
3	Washer	X-6086-23
3	Lug, terminal, aluminum	X-6207-3

Qty.	Description	Part No.
------	-------------	----------

Load Control Module, w/ Terminal Blocks, CSA

GM77177-KP4-QS

1	Load Control Module Assy, w/ Term.	GM77177-2
1	Decal, CSA	297721
1	Decal, equipment grd (NRP)	344295
2	Insert, threaded, #10-24	346258
1	Dimension Print, Load Control Module	ADV-8198
4	Gasket	GM20990
1	Decal, Nameplate	GM21291
2	Label, Blank	GM24703
1	Decal, 120VAC Only	GM75393
1	Plate, Mounting	GM77176
4	Relay,	GM77178
1	Cover w/ Decals, Load Shed	GM77191
1	Enclosure, Load Shed	GM79445
1	Harness, Relay Control	GM80673
8	Harness, Terminal Block	GM80674
4	Block, Terminal	GM80862
1	Indicator, Load Status	GM80879
1	Marker, Strip	GM80949
1	Decal, Wiring Diagram	GM80950
2	Decal, Warning	GM81264
1	PCB Assy, RDC2 Load Control	GM81372-1
1	Diagram, Wiring Load Control	GM81374
1	Diagram, Schematic Load Control	GM81638
1	Transformer, Current	GM83929
1	TT Load Control Module, Res/Comm	TT-1574
1	Terminal block	X-405-2
3	Washer	X-6086-23
3	Lug, terminal, aluminum	X-6207-3

Power Relay Module

GM92001-KP1-QS

1	Dimension Print, Load Management Module	ADV-8742
1	TT 50 Amp Relay Box for Load Shed,	TT-1646
1	Load Management Module	GM92001-1
1	Enclosure, Base	GM91999
1	Enclosure, Cover	GM92000
1	Relay, Sub Assy	GM92005

Programmable Interface Module (PIM)

GM81529-KP1-QS

1	Dimension Print, Programable Intf Module	ADV-8199
1	Diagram, Wiring PIM	GM84085
1	Diagram, Schematic PIM	GM84086
1	Programmable Interface Module (PIM)	TT-1584
1	PIM, Assy NEMA 3R	GM81529-1
1	Decal, Equipment GRD	344295
2	Gasket	GM20990
1	PCB Assy, RDC2 Programmable Interface	GM81372-2
1	Enclosure, PIM	GM81527
1	Silkscreen, Cover	GM82189
1	Decal, Torque	GM82855
1	Decal, PIM	GM84656-3
1	Lug, terminal, aluminum	X-6207-3

Programmable Interface Module (PIM), CSA

GM81529-KP2-QS

1	Dimension Print, Programable Intf Module	ADV-8199
1	Diagram, Wiring PIM	GM84085
1	Diagram, Schematic PIM	GM84086
1	Programmable Interface Module (PIM)	TT-1584
1	PIM, Assy NEMA 3R CSA	GM81529-2
1	Decal, Equipment GRD	344295
2	Gasket	GM20990
1	PCB Assy, RDC2 Programmable Interface	GM81372-2
1	Enclosure, PIM	GM81527
1	Silkscreen, Cover	GM82189
1	Decal, Torque	GM82855
1	Decal, PIM	GM84656-3
1	Lug, terminal, aluminum	X-6207-3

Appendix A Abbreviations

The following list contains abbreviations that may appear in this publication.

A, amp	ampere	cfm	cubic feet per minute	est.	estimated
ABDC	after bottom dead center	CG	center of gravity	E-Stop	emergency stop
AC	alternating current	CID	cubic inch displacement	etc.	et cetera (and so forth)
A/D	analog to digital	CL	centerline	exh.	exhaust
ADC	advanced digital control; analog to digital converter	cm	centimeter	ext.	external
adj.	adjust, adjustment	CMOS	complementary metal oxide substrate (semiconductor)	F	Fahrenheit, female
ADV	advertising dimensional drawing	cogen.	cogeneration	fglass.	fiberglass
Ah	amp-hour	com	communications (port)	FHM	flat head machine (screw)
AHWT	anticipatory high water temperature	coml	commercial	fl. oz.	fluid ounce
AISI	American Iron and Steel Institute	Coml/Rec	Commercial/Recreational	flex.	flexible
ALOP	anticipatory low oil pressure	conn.	connection	freq.	frequency
alt.	alternator	cont.	continued	FS	full scale
Al	aluminum	CPVC	chlorinated polyvinyl chloride	ft.	foot, feet
ANSI	American National Standards Institute (formerly American Standards Association, ASA)	crit.	critical	ft. lb.	foot pounds (torque)
AO	anticipatory only	CRT	cathode ray tube	ft./min.	feet per minute
APDC	Air Pollution Control District	CSA	Canadian Standards Association	ftp	file transfer protocol
API	American Petroleum Institute	CT	current transformer	g	gram
approx.	approximate, approximately	Cu	copper	ga.	gauge (meters, wire size)
AQMD	Air Quality Management District	cUL	Canadian Underwriter's Laboratories	gal.	gallon
AR	as required, as requested	CUL	Canadian Underwriter's Laboratories	gen.	generator
AS	as supplied, as stated, as suggested	cu. in.	cubic inch	genset	generator set
ASE	American Society of Engineers	cw.	clockwise	GFI	ground fault interrupter
ASME	American Society of Mechanical Engineers	CWC	city water-cooled	GND, ⊕	ground
assy.	assembly	cyl.	cylinder	gov.	governor
ASTM	American Society for Testing Materials	D/A	digital to analog	gph	gallons per hour
ATDC	after top dead center	DAC	digital to analog converter	gpm	gallons per minute
ATS	automatic transfer switch	dB	decibel	gr.	grade, gross
auto.	automatic	dB(A)	decibel (A weighted)	GRD	equipment ground
aux.	auxiliary	DC	direct current	gr. wt.	gross weight
avg.	average	DCR	direct current resistance	H x W x D	height by width by depth
AVR	automatic voltage regulator	deg., °	degree	HC	hex cap
AWG	American Wire Gauge	dept.	department	HCHT	high cylinder head temperature
AWM	appliance wiring material	DFMEA	Design Failure Mode and Effects Analysis	HD	heavy duty
bat.	battery	dia.	diameter	HET	high exhaust temp., high engine temp.
BBDC	before bottom dead center	DI/EO	dual inlet/end outlet	hex	hexagon
BC	battery charger, battery charging	DIN	Deutsches Institut für Normung e. V. (also Deutsche Industrie Normenausschuss)	Hg	mercury (element)
BCA	battery charging alternator	DIP	dual inline package	HH	hex head
BCI	Battery Council International	DPDT	double-pole, double-throw	HHC	hex head cap
BDC	before dead center	DS	disconnect switch	HP	horsepower
BHP	brake horsepower	DVR	digital voltage regulator	hr.	hour
blk.	black (paint color), block (engine)	E, emer.	emergency (power source)	HS	heat shrink
blk. htr.	block heater	ECM	electronic control module, engine control module	hsg.	housing
BMEP	brake mean effective pressure	EDI	electronic data interchange	HVAC	heating, ventilation, and air conditioning
bps	bits per second	EFR	emergency frequency relay	HWT	high water temperature
br.	brass	e.g.	for example (<i>exempli gratia</i>)	Hz	hertz (cycles per second)
BTDC	before top dead center	EG	electronic governor	IC	integrated circuit
Btu	British thermal unit	EGSA	Electrical Generating Systems Association	ID	inside diameter, identification
Btu/min.	British thermal units per minute	EIA	Electronic Industries Association	IEC	International Electrotechnical Commission
C	Celsius, centigrade	EI/EO	end inlet/end outlet	IEEE	Institute of Electrical and Electronics Engineers
cal.	calorie	EMI	electromagnetic interference	IMS	improved motor starting
CAN	controller area network	emiss.	emission	in.	inch
CARB	California Air Resources Board	eng.	engine	in. H ₂ O	inches of water
CB	circuit breaker	EPA	Environmental Protection Agency	in. Hg	inches of mercury
cc	cubic centimeter	ES	emergency power system	in. lb.	inch pounds
CCA	cold cranking amps	ESD	electrostatic discharge	Inc.	incorporated
ccw.	counterclockwise			ind.	industrial
CEC	Canadian Electrical Code			int.	internal
cert.	certificate, certification, certified			int./ext.	internal/external
cfh	cubic feet per hour			I/O	input/output
				IP	iron pipe
				ISO	International Organization for Standardization
				J	joule
				JIS	Japanese Industry Standard

k	kilo (1000)	MTBO	mean time between overhauls	rms	root mean square
K	kelvin	mtg.	mounting	rnd.	round
kA	kiloampere	MTU	Motoren-und Turbinen-Union	ROM	read only memory
KB	kilobyte (2 ¹⁰ bytes)	MW	megawatt	rot.	rotate, rotating
KBus	Kohler communication protocol	mW	milliwatt	rpm	revolutions per minute
kg	kilogram	μF	microfarad	RS	right side
kg/cm ²	kilograms per square centimeter	N, norm.	normal (power source)	RTU	remote terminal unit
kgm	kilogram-meter	NA	not available, not applicable	RTV	room temperature vulcanization
kg/m ³	kilograms per cubic meter	nat. gas	natural gas	RW	read/write
kHz	kilohertz	NBS	National Bureau of Standards	SAE	Society of Automotive Engineers
kJ	kilojoule	NC	normally closed	scfm	standard cubic feet per minute
km	kilometer	NEC	National Electrical Code	SCR	silicon controlled rectifier
kOhm, kΩ	kilo-ohm	NEMA	National Electrical Manufacturers Association	s, sec.	second
kPa	kilopascal	NFPA	National Fire Protection Association	SI	<i>Systeme internationale d'unites</i> , International System of Units
kph	kilometers per hour	Nm	newton meter	SI/EO	side in/end out
kV	kilovolt	NO	normally open	sil.	silencer
kVA	kilovolt ampere	no., nos.	number, numbers	SN	serial number
KVAR	kilovolt ampere reactive	NPS	National Pipe, Straight	SNMP	simple network management protocol
kW	kilowatt	NPSC	National Pipe, Straight-coupling	SPDT	single-pole, double-throw
kWh	kilowatt-hour	NPT	National Standard taper pipe thread per general use	SPST	single-pole, single-throw
kWm	kilowatt mechanical	NPTF	National Pipe, Taper-Fine	spec	specification
kWth	kilowatt-thermal	NR	not required, normal relay	specs	specification(s)
L	liter	ns	nanosecond	sq.	square
LAN	local area network	OC	overcrank	sq. cm	square centimeter
L x W x H	length by width by height	OD	outside diameter	sq. in.	square inch
lb.	pound, pounds	OEM	original equipment manufacturer	SS	stainless steel
lbm/ft ³	pounds mass per cubic feet	OF	overfrequency	std.	standard
LCB	line circuit breaker	opt.	option, optional	stl.	steel
LCD	liquid crystal display	OS	oversize, overspeed	tach.	tachometer
ld. shd.	load shed	OSHA	Occupational Safety and Health Administration	TD	time delay
LED	light emitting diode	OV	overvoltage	TDC	top dead center
Lph	liters per hour	oz.	ounce	TDEC	time delay engine cooldown
Lpm	liters per minute	p., pp.	page, pages	TDEN	time delay emergency to normal
LOP	low oil pressure	PC	personal computer	TDES	time delay engine start
LP	liquefied petroleum	PCB	printed circuit board	TDNE	time delay normal to emergency
LPG	liquefied petroleum gas	pF	picofarad	TDOE	time delay off to emergency
LS	left side	PF	power factor	TDON	time delay off to normal
L _{wa}	sound power level, A weighted	ph., ∅	phase	temp.	temperature
LWL	low water level	PHC	Phillips® head Crimptite® (screw)	term.	terminal
LWT	low water temperature	PHH	Phillips® hex head (screw)	THD	total harmonic distortion
m	meter, milli (1/1000)	PHM	pan head machine (screw)	TIF	telephone influence factor
M	mega (10 ⁶ when used with SI units), male	PLC	programmable logic control	TIR	total indicator reading
m ³	cubic meter	PMG	permanent magnet generator	tol.	tolerance
m ³ /hr.	cubic meters per hour	pot	potentiometer, potential	turbo.	turbocharger
m ³ /min.	cubic meters per minute	ppm	parts per million	typ.	typical (same in multiple locations)
mA	milliampere	PROM	programmable read-only memory	UF	underfrequency
man.	manual	psi	pounds per square inch	UHF	ultrahigh frequency
max.	maximum	psig	pounds per square inch gauge	UL	Underwriter's Laboratories, Inc.
MB	megabyte (2 ²⁰ bytes)	pt.	pint	UNC	unified coarse thread (was NC)
MCCB	molded-case circuit breaker	PTC	positive temperature coefficient	UNF	unified fine thread (was NF)
MCM	one thousand circular mils	PTO	power takeoff	univ.	universal
meggar	megohmmeter	PVC	polyvinyl chloride	US	undersize, underspeed
MHz	megahertz	qt.	quart, quarts	UV	ultraviolet, undervoltage
mi.	mile	qty.	quantity	V	volt
mil	one one-thousandth of an inch	R	replacement (emergency) power source	VAC	volts alternating current
min.	minimum, minute	rad.	radiator, radius	VAR	voltampere reactive
misc.	miscellaneous	RAM	random access memory	VDC	volts direct current
MJ	megajoule	RDO	relay driver output	VFD	vacuum fluorescent display
mJ	millijoule	ref.	reference	VGA	video graphics adapter
mm	millimeter	rem.	remote	VHF	very high frequency
mOhm, mΩ	milliohm	Res/Coml	Residential/Commercial	W	watt
MOhm, MΩ	megohm	RFI	radio frequency interference	WCR	withstand and closing rating
MOV	metal oxide varistor	RH	round head	w/	with
MPa	megapascal	RHM	round head machine (screw)	w/o	without
mpg	miles per gallon	rly.	relay	wt.	weight
mph	miles per hour			xfrm	transformer
MS	military standard				
ms	millisecond				
m/sec.	meters per second				
MTBF	mean time between failure				

Appendix B Common Hardware Application Guidelines

Use the information below and on the following pages to identify proper fastening techniques when no specific reference for reassembly is made.

Bolt/Screw Length: When bolt/screw length is not given, use Figure 1 as a guide. As a general rule, a minimum length of one thread beyond the nut and a maximum length of 1/2 the bolt/screw diameter beyond the nut is the preferred method.

Washers and Nuts: Use split lock washers as a bolt locking device where specified. Use SAE flat washers with whiz nuts, spirallock nuts, or standard nuts and preloading (torque) of the bolt in all other applications.

See Appendix C, General Torque Specifications, and other torque specifications in the service literature.

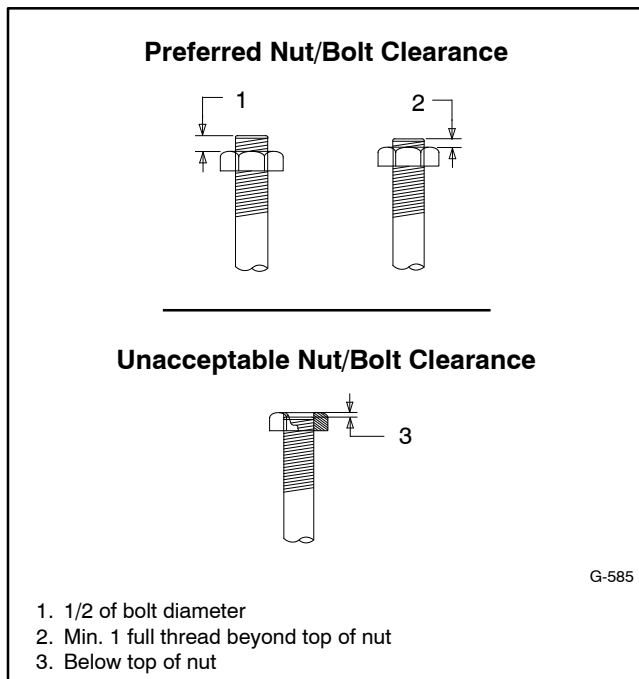

Figure 1 Acceptable Bolt Lengths

Steps for common hardware application:

1. Determine entry hole type: round or slotted.
2. Determine exit hole type: fixed female thread (weld nut), round, or slotted.

For round and slotted exit holes, determine if hardware is greater than 1/2 inch in diameter, or 1/2 inch in diameter or less. Hardware that is *greater than 1/2 inch* in diameter takes a standard nut and SAE washer. Hardware *1/2 inch or less* in diameter can take a properly torqued whiz nut or spirallock nut. See Figure 2.

3. Follow these SAE washer rules after determining exit hole type:
 - a. Always use a washer between hardware and a slot.
 - b. Always use a washer under a nut (see 2 above for exception).
 - c. Use a washer under a bolt when the female thread is fixed (weld nut).
4. Refer to Figure 2, which depicts the preceding hardware configuration possibilities.

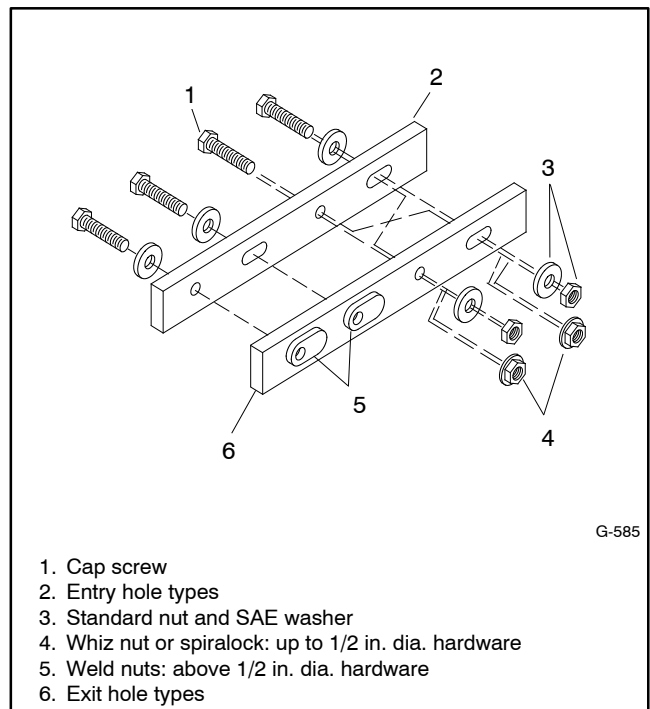

Figure 2 Acceptable Hardware Combinations

Appendix C General Torque Specifications















American Standard Fasteners Torque Specifications					
Size	Torque Measurement	Assembled into Cast Iron or Steel			Assembled into Aluminum Grade 2 or 5
		Grade 2	Grade 5	Grade 8	
8-32	Nm (in. lb.)	1.8 (16)	2.3 (20)	—	See Note 3
10-24	Nm (in. lb.)	2.9 (26)	3.6 (32)	—	
10-32	Nm (in. lb.)	2.9 (26)	3.6 (32)	—	
1/4-20	Nm (in. lb.)	6.8 (60)	10.8 (96)	14.9 (132)	
1/4-28	Nm (in. lb.)	8.1 (72)	12.2 (108)	16.3 (144)	
5/16-18	Nm (in. lb.)	13.6 (120)	21.7 (192)	29.8 (264)	
5/16-24	Nm (in. lb.)	14.9 (132)	23.1 (204)	32.5 (288)	
3/8-16	Nm (ft. lb.)	24.0 (18)	38.0 (28)	53.0 (39)	
3/8-24	Nm (ft. lb.)	27.0 (20)	42.0 (31)	60.0 (44)	
7/16-14	Nm (ft. lb.)	39.0 (29)	60.0 (44)	85.0 (63)	
7/16-20	Nm (ft. lb.)	43.0 (32)	68.0 (50)	95.0 (70)	
1/2-13	Nm (ft. lb.)	60.0 (44)	92.0 (68)	130.0 (96)	
1/2-20	Nm (ft. lb.)	66.0 (49)	103.0 (76)	146.0 (108)	
9/16-12	Nm (ft. lb.)	81.0 (60)	133.0 (98)	187.0 (138)	
9/16-18	Nm (ft. lb.)	91.0 (67)	148.0 (109)	209.0 (154)	
5/8-11	Nm (ft. lb.)	113.0 (83)	183.0 (135)	259.0 (191)	
5/8-18	Nm (ft. lb.)	128.0 (94)	208.0 (153)	293.0 (216)	
3/4-10	Nm (ft. lb.)	199.0 (147)	325.0 (240)	458.0 (338)	
3/4-16	Nm (ft. lb.)	222.0 (164)	363.0 (268)	513.0 (378)	
1-8	Nm (ft. lb.)	259.0 (191)	721.0 (532)	1109.0 (818)	
1-12	Nm (ft. lb.)	283.0 (209)	789.0 (582)	1214.0 (895)	











Metric Fasteners Torque Specifications, Measured in Nm (ft. lb.)				
Size (mm)	Assembled into Cast Iron or Steel			Assembled into Aluminum Grade 5.8 or 8.8
	Grade 5.8	Grade 8.8	Grade 10.9	
M6 x 1.00	6.2 (4.6)	9.5 (7)	13.6 (10)	See Note 3
M8 x 1.25	15.0 (11)	23.0 (17)	33.0 (24)	
M8 x 1.00	16.0 (11)	24.0 (18)	34.0 (25)	
M10 x 1.50	30.0 (22)	45.0 (34)	65.0 (48)	
M10 x 1.25	31.0 (23)	47.0 (35)	68.0 (50)	
M12 x 1.75	53.0 (39)	80.0 (59)	115.0 (85)	
M12 x 1.50	56.0 (41)	85.0 (63)	122.0 (90)	
M14 x 2.00	83.0 (61)	126.0 (93)	180.0 (133)	
M14 x 1.50	87.0 (64)	133.0 (98)	190.0 (140)	
M16 x 2.00	127.0 (94)	194.0 (143)	278.0 (205)	
M16 x 1.50	132.0 (97)	201.0 (148)	287.0 (212)	
M18 x 2.50	179.0 (132)	273.0 (201)	390.0 (288)	
M18 x 1.50	189.0 (140)	289.0 (213)	413.0 (305)	





Notes:

1. The torque values above are general guidelines. Always use the torque values specified in the service manuals and/or assembly drawings when they differ from the above torque values.
2. The torque values above are based on new plated threads. Increase torque values by 15% if non-plated threads are used.
3. Hardware threaded into aluminum must have either two diameters of thread engagement or a 30% or more reduction in the torque to prevent stripped threads.
4. Torque values are calculated as equivalent stress loading on American hardware with an approximate preload of 90% of the yield strength and a friction coefficient of 0.125.

Appendix D Common Hardware Identification

Screw/Bolts/Studs	
Head Styles	
Hex Head or Machine Head	
Hex Head or Machine Head with Washer	
Flat Head (FHM)	
Round Head (RHM)	
Pan Head	
Hex Socket Head Cap or Allen™ Head Cap	
Hex Socket Head or Allen™ Head Shoulder Bolt	
Sheet Metal Screw	
Stud	
Drive Styles	
Hex	
Hex and Slotted	
Phillips®	
Slotted	
Hex Socket	

Nuts	
Nut Styles	
Hex Head	
Lock or Elastic	
Square	
Cap or Acorn	
Wing	
Washers	
Washer Styles	
Plain	
Split Lock or Spring	
Spring or Wave	
External Tooth Lock	
Internal Tooth Lock	
Internal-External Tooth Lock	

Hardness Grades	
American Standard	
Grade 2	
Grade 5	
Grade 8	
Grade 8/9 (Hex Socket Head)	
Metric	
Number stamped on hardware; 5.8 shown	

Allen™ head screw is a trademark of Holo-Krome Co.

Phillips® screw is a registered trademark of Phillips Screw Company.

Sample Dimensions

American Standard (Screws, Bolts, Studs, and Nuts)

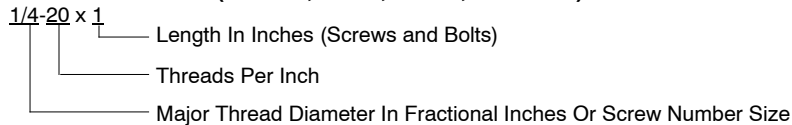

Metric (Screws, Bolts, Studs, and Nuts)

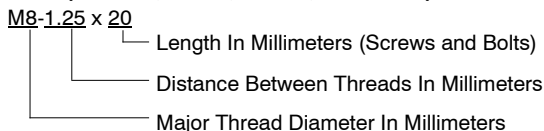

Plain Washers

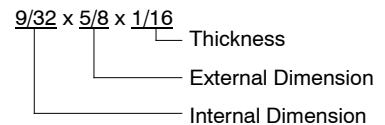

Lock Washers



Appendix E Common Hardware List

The Common Hardware List lists part numbers and dimensions for common hardware items.

American Standard

Part No.	Dimensions	Part No.	Dimensions	Part No.	Dimensions	Type
Hex Head Bolts (Grade 5)						
X-465-17	1/4-20 x .38	X-6238-14	3/8-24 x .75	X-6009-1	1-8	Standard
X-465-6	1/4-20 x .50	X-6238-16	3/8-24 x 1.25	X-6210-3	6-32	Whiz
X-465-2	1/4-20 x .62	X-6238-21	3/8-24 x 4.00	X-6210-4	8-32	Whiz
X-465-16	1/4-20 x .75	X-6238-22	3/8-24 x 4.50	X-6210-5	10-24	Whiz
X-465-18	1/4-20 x .88			X-6210-1	10-32	Whiz
X-465-7	1/4-20 x 1.00	X-6024-5	7/16-14 x .75			
X-465-8	1/4-20 x 1.25	X-6024-2	7/16-14 x 1.00	X-6210-2	1/4-20	Spiralock
X-465-9	1/4-20 x 1.50	X-6024-8	7/16-14 x 1.25	X-6210-6	1/4-28	Spiralock
X-465-10	1/4-20 x 1.75	X-6024-3	7/16-14 x 1.50	X-6210-7	5/16-18	Spiralock
X-465-11	1/4-20 x 2.00	X-6024-4	7/16-14 x 2.00	X-6210-8	5/16-24	Spiralock
X-465-12	1/4-20 x 2.25	X-6024-11	7/16-14 x 2.75	X-6210-9	3/8-16	Spiralock
X-465-14	1/4-20 x 2.75	X-6024-12	7/16-14 x 6.50	X-6210-10	3/8-24	Spiralock
X-465-21	1/4-20 x 5.00	X-129-15	1/2-13 x .75	X-6210-11	7/16-14	Spiralock
X-465-25	1/4-28 x .38	X-129-17	1/2-13 x 1.00	X-6210-12	1/2-13	Spiralock
X-465-20	1/4-28 x 1.00	X-129-18	1/2-13 x 1.25	X-6210-15	7/16-20	Spiralock
		X-129-19	1/2-13 x 1.50	X-6210-14	1/2-20	Spiralock
X-125-33	5/16-18 x .50	X-129-20	1/2-13 x 1.75			
X-125-23	5/16-18 x .62	X-129-21	1/2-13 x 2.00	X-85-3	5/8-11	Standard
X-125-3	5/16-18 x .75	X-129-22	1/2-13 x 2.25	X-88-12	3/4-10	Standard
X-125-31	5/16-18 x .88	X-129-23	1/2-13 x 2.50	X-89-2	1/2-20	Standard
X-125-5	5/16-18 x 1.00	X-129-24	1/2-13 x 2.75			
X-125-24	5/16-18 x 1.25	X-129-25	1/2-13 x 3.00			
X-125-34	5/16-18 x 1.50	X-129-27	1/2-13 x 3.50			
X-125-25	5/16-18 x 1.75	X-129-29	1/2-13 x 4.00			
X-125-26	5/16-18 x 2.00	X-129-30	1/2-13 x 4.50			
230578	5/16-18 x 2.25	X-463-9	1/2-13 x 5.50			
X-125-29	5/16-18 x 2.50	X-129-44	1/2-13 x 6.00			
X-125-27	5/16-18 x 2.75					
X-125-28	5/16-18 x 3.00	X-129-51	1/2-20 x .75			
X-125-22	5/16-18 x 4.50	X-129-45	1/2-20 x 1.25			
X-125-32	5/16-18 x 5.00	X-129-52	1/2-20 x 1.50			
X-125-35	5/16-18 x 5.50					
X-125-36	5/16-18 x 6.00	X-6021-3	5/8-11 x 1.00			
X-125-40	5/16-18 x 6.50	X-6021-4	5/8-11 x 1.25			
		X-6021-2	5/8-11 x 1.50			
X-125-43	5/16-24 x 1.75	X-6021-1	5/8-11 x 1.75			
X-125-44	5/16-24 x 2.50	273049	5/8-11 x 2.00			
X-125-30	5/16-24 x .75	X-6021-5	5/8-11 x 2.25			
X-125-39	5/16-24 x 2.00	X-6021-6	5/8-11 x 2.50			
X-125-38	5/16-24 x 2.75	X-6021-7	5/8-11 x 2.75			
		X-6021-12	5/8-11 x 3.75			
X-6238-2	3/8-16 x .62	X-6021-11	5/8-11 x 4.50			
X-6238-10	3/8-16 x .75	X-6021-10	5/8-11 x 6.00			
X-6238-3	3/8-16 x .88					
X-6238-11	3/8-16 x 1.00	X-6021-9	5/8-18 x 2.50			
X-6238-4	3/8-16 x 1.25					
X-6238-5	3/8-16 x 1.50	X-6239-1	3/4-10 x 1.00			
X-6238-1	3/8-16 x 1.75	X-6239-8	3/4-10 x 1.25			
X-6238-6	3/8-16 x 2.00	X-6239-2	3/4-10 x 1.50			
X-6238-17	3/8-16 x 2.25	X-6239-3	3/4-10 x 2.00			
X-6238-7	3/8-16 x 2.50	X-6239-4	3/4-10 x 2.50			
X-6238-8	3/8-16 x 2.75	X-6239-5	3/4-10 x 3.00			
X-6238-9	3/8-16 x 3.00	X-6239-6	3/4-10 x 3.50			
X-6238-19	3/8-16 x 3.25					
X-6238-12	3/8-16 x 3.50	X-792-1	1-8 x 2.25			
X-6238-20	3/8-16 x 3.75	X-792-5	1-8 x 3.00			
X-6238-13	3/8-16 x 4.50	X-792-8	1-8 x 5.00			
X-6238-18	3/8-16 x 5.50					
X-6238-25	3/8-16 x 6.50					

Hex Nuts				Washers	
Part No.	Dimensions	Type	Part No.	ID	OD
X-6009-1	1-8	Standard	X-25-46	.125	.250
X-6210-3	6-32	Whiz	X-25-9	.156	.375
X-6210-4	8-32	Whiz	X-25-48	.188	.438
X-6210-5	10-24	Whiz	X-25-36	.219	.500
X-6210-1	10-32	Whiz	X-25-40	.281	.625
			X-25-85	.344	.687
X-6210-2	1/4-20	Spiralock	X-25-37	.406	.812
X-6210-6	1/4-28	Spiralock	X-25-34	.469	.922
X-6210-7	5/16-18	Spiralock	X-25-26	.531	1.062
X-6210-8	5/16-24	Spiralock	X-25-15	.656	1.312
X-6210-9	3/8-16	Spiralock	X-25-29	.812	1.469
X-6210-10	3/8-24	Spiralock	X-25-127	1.062	2.000
X-6210-11	7/16-14	Spiralock			
X-6210-12	1/2-13	Spiralock			
X-6210-15	7/16-20	Spiralock			
X-6210-14	1/2-20	Spiralock			

Part No.	ID	OD	Thick.	Bolt/ Screw
X-25-46	.125	.250	.022	#4
X-25-9	.156	.375	.049	#6
X-25-48	.188	.438	.049	#8
X-25-36	.219	.500	.049	#10
X-25-40	.281	.625	.065	1/4
X-25-85	.344	.687	.065	5/16
X-25-37	.406	.812	.065	3/8
X-25-34	.469	.922	.065	7/16
X-25-26	.531	1.062	.095	1/2
X-25-15	.656	1.312	.095	5/8
X-25-29	.812	1.469	.134	3/4
X-25-127	1.062	2.000	.134	1

Metric

Hex head bolts are hardness grade 8.8 unless noted.

Part No.	Dimensions	Part No.	Dimensions	Part No.	Dimensions
Hex Head Bolts (Partial Thread)		Hex Head Bolts (Partial Thread), continued		Hex Head Bolts (Full Thread), continued	
M931-05055-60	M5-0.80 x 55	M960-16090-60	M16-1.50 x 90	M933-12016-60	M12-1.75 x 16
M931-06040-60	M6-1.00 x 40	M931-16090-60	M16-2.00 x 90	M933-12020-60	M12-1.75 x 20
M931-06055-60	M6-1.00 x 55	M931-16100-60	M16-2.00 x 100	M961-12020-60F	M12-1.50 x 20
M931-06060-60	M6-1.00 x 60	M931-16100-82	M16-2.00 x 100*	M933-12025-60	M12-1.75 x 25
M931-06060-SS	M6-1.00 x 60	M931-16120-60	M16-2.00 x 120	M933-12025-82	M12-1.75 x 25*
M931-06070-60	M6-1.00 x 70	M931-16150-60	M16-2.00 x 150	M961-12030-60	M12-1.25 x 30
M931-06070-SS	M6-1.00 x 70			M933-12030-82	M12-1.75 x 30*
M931-06075-60	M6-1.00 x 75	M931-20065-60	M20-2.50 x 65	M961-12030-82F	M12-3.00 x 30*
M931-06090-60	M6-1.00 x 90	M931-20090-60	M20-2.50 x 90	M933-12030-60	M12-1.75 x 30
M931-06145-60	M6-1.00 x 145	M931-20100-60	M20-2.50 x 100	M933-12035-60	M12-1.75 x 35
M931-06150-60	M6-1.00 x 150	M931-20120-60	M20-2.50 x 120	M961-12040-82	M12-1.25 x 40*
		M931-20140-60	M20-2.50 x 140	M933-12040-60	M12-1.75 x 40
M931-08035-60	M8-1.25 x 35	M931-20160-60	M20-2.50 x 160	M933-12040-82	M12-1.75 x 40*
M931-08040-60	M8-1.25 x 40				
M931-08045-60	M8-1.25 x 45	M931-22090-60	M22-2.50 x 90	M961-14025-60	M14-1.50 x 25
M931-08050-60	M8-1.25 x 50	M931-22120-60	M22-2.50 x 120	M933-14025-60	M14-2.00 x 25
M931-08055-60	M8-1.25 x 55	M931-22160-60	M22-2.50 x 160	M961-14050-82	M14-1.50 x 50*
M931-08055-82	M8-1.25 x 55*				
M931-08060-60	M8-1.25 x 60	M931-24090-60	M24-3.00 x 90	M961-16025-60	M16-1.50 x 25
M931-08070-60	M8-1.25 x 70	M931-24120-60	M24-3.00 x 120	M933-16025-60	M16-2.00 x 25
M931-08070-82	M8-1.25 x 70*	M931-24160-60	M24-3.00 x 160	M961-16030-82	M16-1.50 x 30*
M931-08075-60	M8-1.25 x 75	M931-24200-60	M24-3.00 x 200	M933-16030-82	M16-2.00 x 30*
M931-08080-60	M8-1.25 x 80			M933-16035-60	M16-2.00 x 35
M931-08090-60	M8-1.25 x 90	Hex Head Bolts (Full Thread)		M961-16040-60	M16-1.50 x 40
M931-08095-60	M8-1.25 x 95	M933-04006-60	M4-0.70 x 6	M933-16040-60	M16-2.00 x 40
M931-08100-60	M8-1.25 x 100			M961-16045-82	M16-1.50 x 45*
M931-08110-60	M8-1.25 x 110	M933-05030-60	M5-0.80 x 30	M933-16045-82	M16-2.00 x 45*
M931-08120-60	M8-1.25 x 120	M933-05035-60	M5-0.80 x 35	M933-16050-60	M16-2.00 x 50
M931-08130-60	M8-1.25 x 130	M933-05050-60	M5-0.80 x 50	M933-16050-82	M16-2.00 x 50*
M931-08140-60	M8-1.25 x 140			M933-16060-60	M16-2.00 x 60
M931-08150-60	M8-1.25 x 150			M933-16070-60	M16-2.00 x 70
M931-08200-60	M8-1.25 x 200				
				M933-18035-60	M18-2.50 x 35
M931-10040-82	M10-1.25 x 40*			M933-18050-60	M18-2.50 x 50
M931-10040-60	M10-1.50 x 40			M933-18060-60	M18-2.50 x 60
M931-10045-60	M10-1.50 x 45				
M931-10050-60	M10-1.50 x 50			M933-20050-60	M20-2.50 x 50
M931-10050-82	M10-1.25 x 50*			M933-20055-60	M20-2.50 x 55
M931-10055-60	M10-1.50 x 55				
M931-10060-60	M10-1.50 x 60			M933-24060-60	M24-3.00 x 60
M931-10065-60	M10-1.50 x 65			M933-24065-60	M24-3.00 x 65
M931-10070-60	M10-1.50 x 70	M933-07025-60	M7-1.00 x 25	M933-24070-60	M24-3.00 x 70
M931-10080-60	M10-1.50 x 80				
M931-10080-82	M10-1.25 x 80*	M933-08010-60	M8-1.25 x 10	Pan Head Machine Screws	
M931-10090-60	M10-1.50 x 90	M933-08012-60	M8-1.25 x 12	M7985A-03010-20	M3-0.50 x 10
M931-10090-82	M10-1.50 x 90*	M933-08016-60	M8-1.25 x 16	M7985A-03012-20	M3-0.50 x 12
M931-10100-60	M10-1.50 x 100	M933-08020-60	M8-1.25 x 20		
M931-10110-60	M10-1.50 x 110	M933-08025-60	M8-1.25 x 25	M7985A-04010-20	M4-0.70 x 10
M931-10120-60	M10-1.50 x 120	M933-08030-60	M8-1.25 x 30	M7985A-04016-20	M4-0.70 x 16
M931-10130-60	M10-1.50 x 130	M933-08030-82	M8-1.25 x 30*	M7985A-04020-20	M4-0.70 x 20
M931-10140-60	M10-1.50 x 140			M7985A-04050-20	M4-0.70 x 50
M931-10180-60	M10-1.50 x 180	M933-10012-60	M10-1.50 x 12	M7985A-04100-20	M4-0.70 x 100
M931-10235-60	M10-1.50 x 235	M961-10020-60	M10-1.25 x 20		
M931-10260-60	M10-1.50 x 260	M933-10020-60	M10-1.50 x 20	M7985A-05010-20	M5-0.80 x 10
M960-10330-60	M10-1.25 x 330	M933-10025-60	M10-1.50 x 25	M7985A-05012-20	M5-0.80 x 12
		M961-10025-60	M10-1.25 x 25	M7985A-05016-20	M5-0.80 x 16
M931-12045-60	M12-1.75 x 45	M933-10025-82	M10-1.50 x 25*	M7985A-05020-20	M5-0.80 x 20
M960-12050-60	M12-1.25 x 50	M961-10030-60	M10-1.25 x 30	M7985A-05025-20	M5-0.80 x 25
M960-12050-82	M12-1.25 x 50*	M933-10030-60	M10-1.50 x 30	M7985A-05030-20	M5-0.80 x 30
M931-12050-60	M12-1.75 x 50	M933-10030-82	M10-1.50 x 30*	M7985A-05080-20	M5-0.80 x 80
M931-12050-82	M12-1.75 x 50*	M961-10035-60	M10-1.25 x 35	M7985A-05100-20	M5-0.80 x 100
M931-12055-60	M12-1.75 x 55	M933-10035-60	M10-1.50 x 35		
M931-12060-60	M12-1.75 x 60	M933-10035-82	M10-1.50 x 35*	M7985A-06100-20	M6-1.00 x 100
M931-12060-82	M12-1.75 x 60*	M961-10040-60	M10-1.25 x 40		
M931-12065-60	M12-1.75 x 65			Flat Head Machine Screws	
M931-12075-60	M12-1.75 x 75			M965A-04012-SS	M4-0.70 x 12
M931-12080-60	M12-1.75 x 80				
M931-12090-60	M12-1.75 x 90			M965A-05012-SS	M5-0.80 x 12
M931-12100-60	M12-1.75 x 100			M965A-05016-20	M5-0.80 x 16
M931-12110-60	M12-1.75 x 110			M965A-06012-20	M6-1.00 x 12

* This metric hex bolt's hardness is grade 10.9.

Metric, continued

Part No.	Dimensions	Type
Hex Nuts		
M934-03-50	M3-0.50	Standard
M934-04-50	M4-0.70	Standard
M934-04-B	M4-0.70	Brass
M934-05-50	M5-0.80	Standard
M934-06-60	M6-1.00	Standard
M934-06-64	M6-1.00	Std. (green)
M6923-06-80	M6-1.00	Spirallock
M982-06-80	M6-1.00	Elastic Stop
M934-08-60	M8-1.25	Standard
M6923-08-80	M8-1.25	Spirallock
M982-08-80	M8-1.25	Elastic Stop
M934-10-60	M10-1.50	Standard
M934-10-60F	M10-1.25	Standard
M6923-10-80	M10-1.50	Spirallock
M6923-10-62	M10-1.50	Spirallock†
M982-10-80	M10-1.50	Elastic Stop
M934-12-60	M12-1.75	Standard
M934-12-60F	M12-1.25	Standard
M6923-12-80	M12-1.75	Spirallock
M982-12-80	M12-1.75	Elastic Stop
M982-14-60	M14-2.00	Elastic Stop
M6923-16-80	M16-2.00	Spirallock
M982-16-80	M16-2.00	Elastic Stop
M934-18-80	M18-2.5	Standard
M982-18-60	M18-2.50	Elastic Stop
M934-20-80	M20-2.50	Standard
M982-20-80	M20-2.50	Elastic Stop
M934-22-60	M22-2.50	Standard
M934-24-80	M24-3.00	Standard
M982-24-60	M24-3.00	Elastic Stop
M934-30-80	M30-3.50	Standard

Washers

Part No.	ID	OD	Thick.	Bolt/ Screw
M125A-03-80	3.2	7.0	0.5	M3
M125A-04-80	4.3	9.0	0.8	M4
M125A-05-80	5.3	10.0	1.0	M5
M125A-06-80	6.4	12.0	1.6	M6
M125A-08-80	8.4	16.0	1.6	M8
M125A-10-80	10.5	20.0	2.0	M10
M125A-12-80	13.0	24.0	2.5	M12
M125A-14-80	15.0	28.0	2.5	M14
M125A-16-80	17.0	30.0	3.0	M16
M125A-18-80	19.0	34.0	3.0	M18
M125A-20-80	21.0	37.0	3.0	M20
M125A-24-80	25.0	44.0	4.0	M24

† This metric hex nut's hardness is grade 8.

Index

Listed below are part numbers and page numbers of modules listed in this manual. Italicized numbers refer to the page numbers on which modules appear.

GM87474-MA1, <i>23</i>	GM91321-MA18, <i>33</i>	GM97041-MA3, <i>27</i>
GM87474-MA2, <i>23</i>	GM91321-MA19, <i>33</i>	GM97041-MA4, <i>27</i>
GM91044-MA1, <i>34</i>	GM91321-MA2, <i>33</i>	GM97041-MA5, <i>27</i>
GM91044-MA2, <i>34</i>	GM91321-MA20, <i>33</i>	GM97041-MA6, <i>27</i>
GM91321-MA1, <i>33</i>	GM91321-MA3, <i>33</i>	GM97051-MA1, <i>35</i>
GM91321-MA13, <i>33</i>	GM91321-MA4, <i>33</i>	GM97051-MA2, <i>35</i>
GM91321-MA16, <i>33</i>	GM97041-MA1, <i>27</i>	
GM91321-MA17, <i>33</i>	GM97041-MA2, <i>27</i>	

KOHLER[®] Power Systems

KOHLER CO. Kohler, Wisconsin 53044
Phone 920-457-4441, Fax 920-459-1646

Kohler Power Systems
Asia Pacific Headquarters
7 Jurong Pier Road
Singapore 619159
Phone (65) 6264-6422, Fax (65) 6264-6455

**For the nearest KOHLER authorized
installation, service, and sales dealer in
the US and Canada:
Call 1-800-544-2444 or visit
KOHLERPower.com**

TP-6908 4/16b

© 2014, 2016 by Kohler Co. All rights reserved.